



*Operator's Manual  
& Parts Drawings*

# EB480

*Aerator*





500 Venture Drive  
Orrville Oh 44667  
www.ventrac.com

View all manuals



Visit [ventrac.com/manuals](http://ventrac.com/manuals) for the latest version of this operator's manual.

A downloadable parts manual is also available.

### To the Owner Contact Information and Product Identification

If you need to contact an authorized Ventrac dealer for information on servicing your product, always provide the product model and serial numbers.

*Please fill in the following information for future reference. See the picture(s) below to find the location of the identification numbers. Record them in the spaces provided.*

Date of Purchase: \_\_\_\_\_

Dealer: \_\_\_\_\_

Dealer Address: \_\_\_\_\_

Dealer Phone Number: \_\_\_\_\_

Dealer Fax Number: \_\_\_\_\_

Model # (A): \_\_\_\_\_

Serial # (B): \_\_\_\_\_

Affix Part/Serial Number label here.

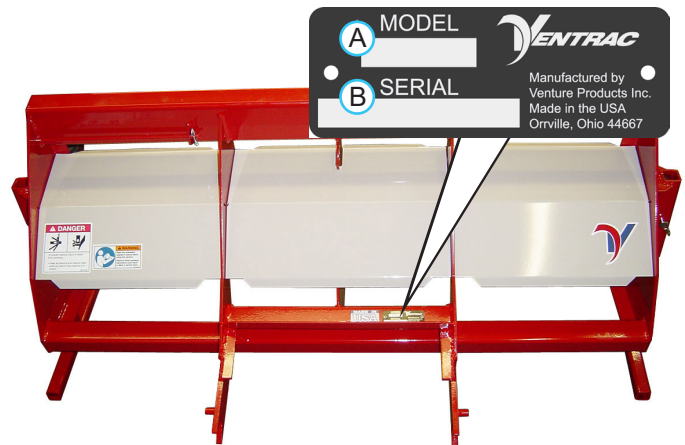

Venture Products Inc. reserves the right to make changes in design or specifications without obligation to make like changes on previously manufactured products.

# TABLE OF CONTENTS

---

<b>INTRODUCTION</b>	<b>PAGE 4</b>
Product Description.....	4
Why Do I Need an Operator’s Manual? .....	4
Using Your Manual .....	5
Manual Glossary .....	5
<b>SAFETY</b>	<b>PAGE 6</b>
Safety Decals .....	6
General Safety Procedures.....	7
Training Required.....	7
Personal Protective Equipment Requirements .....	7
Operation Safety .....	7
Preventing Accidents.....	8
Keep Riders Off.....	8
Operating On Slopes.....	9
Roadway Safety .....	9
Truck Or Trailer Transport .....	9
Maintenance.....	10
Fuel Safety .....	10
Hydraulic Safety .....	11
EB480 Safety Procedures.....	12
<b>GENERAL OPERATION</b>	<b>PAGE 13</b>
Daily Inspection.....	13
Attaching .....	13
Detaching .....	13
Operating Procedures .....	13
<b>SERVICE</b>	<b>PAGE 14</b>
Cleaning and General Maintenance.....	14
Lubrication.....	14
Storage.....	14
<b>SPECIFICATIONS</b>	<b>PAGE 15</b>
Dimensions .....	15
<b>PARTS</b>	<b>PAGE 16</b>
Main Frame & Shields.....	16
Rotor Shaft, Reels, & Tines Kits (Serial # 1001-1075).....	18
Rotor Shaft, Reels, & Tines Kits (Serial # 1076-).....	20
<b>WARRANTY</b>	<b>PAGE 22</b>

# INTRODUCTION



Venture Products Inc. is pleased to provide you with your new Ventrac aerator! We hope that Ventrac equipment will provide you with a ONE Tractor Solution.

Listed below are just some of the items that can provide you *versatility* as you use your EB480 aerator. Please visit our web site, or contact your authorized Ventrac dealer for a complete list of items available for your new aerator.

Accessories	Item Description	Part Number
	Core Tine Spring Kit (for Core Tines & Open Spoon Tines)	70.8071

## Product Description

The Ventrac EB480 aerator is designed for the sole purpose of turf aeration. Aeration helps to revitalize and encourage root growth by increasing the oxygen supply to the root zone. It allows entry of fertilizer and organic top dressing and reduces soil compaction in heavily used areas.

The EB480 aerator features three different tine options;

- the **core** tine is a hardened steel 3/4" (19 mm) tine. It removes a core up to 3 inches (76 mm) deep.
- the **open spoon** tine is a hardened steel 3/4" (19 mm) tine that is designed to penetrate and loosen compacted soil without removing a core.
- the **slitter/slicer** tine is a 1/4" (6.4 mm) wide steel tine that is designed to slice through thatch and turf without removing a core.

Additional weight may be added to the aerator for easier penetration of aerator tines in heavily compacted areas or hard clay soil. The aerator frame is designed with a mounting area to accommodate up to eight Ventrac weights (or 340 pounds (154 Kg) of weight).

## Why Do I Need an Operator's Manual?

This manual has been created to help you gain the important knowledge of what is needed to safely operate, maintain, and service your machine. It is divided into sections for convenient reference of the appropriate section.

You must read and understand the operator's manual for each piece of Ventrac equipment you own. Reading the operator's manual will help you become familiar with each specific piece of equipment. Understanding the operator's manual will help you, as well as others, avoid personal injury and/or damage to the equipment. Keep this manual with the machine at all times. The manual should remain with the machine even if it is sold. If this manual becomes damaged or unreadable, it should be replaced immediately. Contact your local Ventrac dealer for a replacement.

When using a Ventrac attachment, be sure to read and follow the safety and operating instructions of both the power unit and the attachment being used to ensure the safest operation possible.

The information in this manual provides the operator with the safest procedures to operate the machine while getting the maximum use out of the unit. Failure to follow the safety precautions listed in this manual may result in personal injury and/or damage to the equipment.

# INTRODUCTION

---

## Using Your Manual

Throughout this manual, you will encounter special messages and symbols that identify potential safety concerns to help you as well as others avoid personal injury or damage to the equipment.

### SYMBOL DEFINITIONS



#### **ATTENTION**

This symbol identifies potential health and safety hazards. It marks safety precautions. Your safety and the safety of others is involved.

There are three signal words that describe the level of safety concern: Danger, Warning, and Caution. Safety should always be the #1 priority when working on or operating equipment. Accidents are more likely to occur when proper operating procedures are not followed or inexperienced operators are involved.

Note: Right-Hand and Left-Hand orientations may be referred to at different places throughout this manual. Right-Hand and Left-Hand is determined as if sitting on the power unit seat facing forward.

### SIGNAL WORD DEFINITIONS

#### **⚠ DANGER**

Indicates an imminently hazardous situation which, if not avoided, will result in death or serious injury. This signal word is limited to the most extreme cases.

#### **⚠ WARNING**

Indicates a potentially hazardous situation which, if not avoided, could result in death or serious injury.

#### **⚠ CAUTION**

Indicates a potentially hazardous situation which, if not avoided, may result in minor or moderate injury and/or property damage. It may also be used to alert against unsafe practices.

## Manual Glossary

- Power Unit** A Ventrac tractor or other Ventrac engine powered device that may be operated by itself or with an attachment or accessory.
- Attachment** A piece of Ventrac equipment that requires a Power Unit for operation.
- Accessory** A device that attaches to a Power Unit or Attachment to extend its capabilities.
- Machine** Describes any "Attachment" or "Accessory" that is used in conjunction with a power unit.

# SAFETY

## Safety Decals

The following safety decals must be maintained on your EB480 Aerator.

Keep all safety decals legible. Remove all grease, dirt, and debris from safety decals and instructional labels. If any decals are faded, illegible, or missing, contact your dealer promptly for replacements.

When new components are installed, be sure that current safety decals are affixed to the replacement components.



Decal	Description	Part Number	Quantity
A	Danger - Pinching Hazard	00.0102	1
B	Warning - Read Owner's Manual	00.0217	1

# SAFETY



## General Safety Procedures for Ventrac Power Units, Attachments, & Accessories



### Training Required

- The owner of this machine is solely responsible for properly training the operators.
- The owner/operator is solely responsible for the operation of this machine and prevention of accidents or injuries occurring to him/herself, other people, or property.
- Do not allow operation or service by children or untrained personnel. Local regulations may restrict the age of the operator.
- Before operating this machine, read the operator's manual and understand its contents.
- If the operator of the machine cannot understand this manual, then it is the responsibility of this machine's owner to fully explain the material within this manual to the operator.
- Learn and understand the use of all controls.
- Know how to stop the power unit and all attachments quickly in the event of an emergency.



### Personal Protective Equipment Requirements

It is the responsibility of the owner to be sure that the operators use the proper personal protective equipment while operating the machine. Required personal protective equipment includes, but is not limited to, the following list.



- Wear a certified ear protection device to prevent loss of hearing.
- Prevent eye injury by wearing safety glasses while operating the machine.
- Closed toe shoes must be worn at all times.
- Long pants must be worn at all times.
- When operating in dusty conditions, it is recommended that a dust mask be worn.

### Operation Safety

- Inspect machine before operation. Repair or replace any damaged, worn, or missing parts. Be sure guards and shields are in proper working condition and are secured in place. Make all necessary adjustments before operating machine.
- Some pictures in this manual may show shields or covers opened or removed in order to clearly illustrate any instructions. Under no circumstance should the machine be operated without these devices in place.
- Alterations or modifications to this machine can reduce safety and could cause damage to the machine. Do not alter safety devices or operate with shields or covers removed.
- Before each use, verify that all controls function properly and inspect all safety devices. Do not operate if controls or safety devices are not in proper working condition.
- Check parking brake function before operating. Repair or adjust parking brake if necessary.
- Observe and follow all safety decals.
- All controls are to be operated from the operator's station only.
- Always wear a seat belt if the machine has a roll cage/bar installed and in upright position.
- Ensure the attachment or accessory is locked or fastened securely to the power unit before operating.
- Ensure that all bystanders are clear of the power unit and attachment before operating. Stop machine if someone enters your work area.
- Always be alert to what is happening around you, but do not lose focus on the task you are performing. Always look in the direction the machine is moving.
- Look behind and down before backing up to be sure of a clear path.
- If you hit an object, stop and inspect the machine. Make all necessary repairs before operating machine again.
- Stop operation immediately at any sign of equipment failure. An unusual noise can be a warning of equipment failure or a sign that maintenance is required. Make all necessary repairs before operating machine again.

# SAFETY



## General Safety Procedures for Ventrac Power Units, Attachments, & Accessories



### Operation Safety (continued)

- If equipped with a high/low range feature, never shift between high and low range while on a slope. Always move the machine to level ground and engage the parking brake before shifting range.
- Do not leave machine unattended while it is running.
- Always park the machine on level ground.
- Always shut off engine when connecting attachment drive belt to the power unit.
- Never leave the operator's station without lowering the attachment to the ground, setting the parking brake, shutting off the engine, and removing the ignition key. Make sure all moving parts have come to a complete stop before dismounting.
- Never leave equipment unattended without lowering the attachment to the ground, setting the parking brake, shutting off the engine, and removing the ignition key.
- Only operate in well-lit conditions.
- Do not operate when there is a risk of lightning.
- Never direct the discharge of any attachment in the direction of people, buildings, animals, vehicles, or other objects of value.
- Never discharge material against a wall or obstruction. Material may ricochet back towards the operator.
- Use extra caution when approaching blind corners, shrubs, trees, or other objects that may obscure vision.
- Do not run the engine in a building without adequate ventilation.
- Do not touch the engine or the muffler while the engine is running or immediately after stopping the engine. These areas may be hot enough to cause a burn.
- Do not change the engine governor settings or over-speed the engine. Operating engine at excessive speed may increase the hazard of personal injury.
- To reduce the hazard of fire, keep the battery compartment, engine, and muffler areas free of grass, leaves, excessive grease, and other flammable materials.

### Preventing Accidents



- Clear working area of objects that might be hit or thrown from machine.
- Keep people and pets out of working area.
- Know the work area well before operation. Do not operate where traction or stability is questionable.
- Reduce speed when you are operating over rough ground.
- Equipment can cause serious injury and/or death when improperly used. Before operating, know and understand the operation and safety of the power unit and the attachment being used.

- Do not operate machine if you are not in good physical and mental health, if you will be distracted by personal devices, or are under the influence of any substance which might impair decision, dexterity, or judgment.
- Children are attracted to machine activity. Be aware of children and do not allow them in the working area. Turn off the machine if a child enters the work area.

### Keep Riders Off

- Only allow the operator on the power unit. Keep riders off.
- Never allow riders on any attachment or accessory.

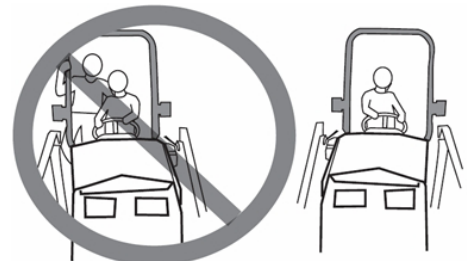



# SAFETY



## General Safety Procedures for Ventrac Power Units, Attachments, & Accessories



### Operating On Slopes

- Slopes can cause loss-of-control and tip-over accidents, which can result in severe injury or death. Be familiar with the emergency parking brake, along with the power unit controls and their functions.
- If power unit is equipped with a fold down roll bar, it must be locked in the upright position when operating on any slope.
- Use low range (if equipped) when operating on slopes greater than 15 degrees.
- Do not stop or start suddenly when operating on slopes.
- Never shift between high and low range while on a slope. Always move the power unit to level ground and engage the parking brake before shifting range or placing the power unit in neutral.
- Variables such as wet surface and loose ground will reduce the degree of safety. Do not drive where machine could lose traction or tip over.
- Keep alert for hidden hazards in the terrain.
- Stay away from drop-offs, ditches, and embankments.
- Sharp turns should be avoided when operating on slopes.
- Pulling loads on hills decreases safety. It is the responsibility of the owner/operator to determine loads that can safely be controlled on slopes.
- Transport machine with attachment lowered or close to the ground to improve stability.
- While operating on slopes, drive in an up and down direction when possible. If turning is necessary while driving across slopes, reduce speed and turn slowly in the downhill direction.
- Assure a sufficient supply of fuel for continuous operation. A minimum of one-half tank of fuel is recommended.

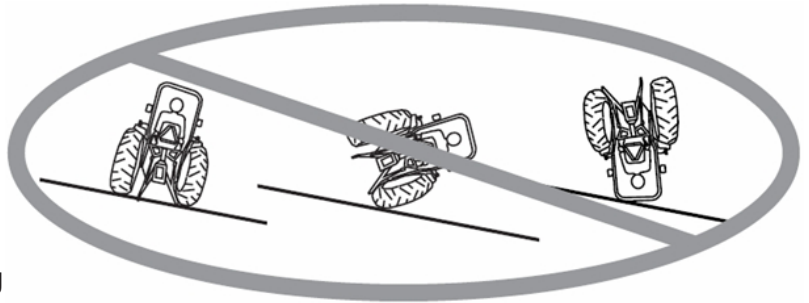

### Roadway Safety

- Operate with safety lights when operating on or near roadways.
- Obey all state and local laws concerning operation on roadways.
- Slow down and be careful of traffic when operating near or crossing roadways. Stop before crossing roads or sidewalks. Use care when approaching areas or objects that may obscure vision.
- If there is doubt of safety conditions, discontinue machine operation until a time when operation can be performed safely.
- When operating near or on roadways, have a Slow Moving Vehicle Emblem clearly displayed.

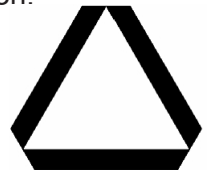

### Truck Or Trailer Transport

- Use care when loading or unloading machine into a truck or trailer.
- Use full width ramps for loading machine into a truck or trailer.
- The parking brake is not sufficient to lock the machine during transport. Always secure the power unit and/or attachment to the transporting vehicle securely using straps, chains, cable, or ropes. Both front and rear straps should be directed down and outward from the machine.
- Shut off fuel supply to power unit during transport on truck or trailer.
- If equipped, turn the battery disconnect switch to the Off position to shut off electrical power.

# SAFETY



## General Safety Procedures for Ventrac Power Units, Attachments, & Accessories



### Maintenance

- Keep all safety decals legible. Remove all grease dirt, and debris from safety decals and instructional labels.
- If any decals are faded, illegible, or missing, contact your dealer promptly for replacements.
- When new components are installed, be sure that current safety decals are affixed to the replacement components.
- If any component requires replacement, use only original Ventrac replacement parts.
- Always turn the battery disconnect to the Off position or disconnect the battery before performing any repairs. Disconnect the negative terminal first and the positive terminal last. Reconnect the positive terminal first and the negative terminal last.
- Keep all bolts, nuts, screws, and other fasteners properly tightened.
- Always lower the attachment to the ground, engage parking brake, shut off engine, and remove the ignition key. Make sure all moving parts have come to a complete stop before cleaning, inspection, adjusting or repairing.
- If the power unit, attachment, or accessory requires repairs or adjustments not instructed in the operator's manual, the power unit, attachment, or accessory must be taken to an authorized Ventrac dealer for service.
- Never perform maintenance on the power unit and/or attachment if someone is in the operator's station.
- Always use protective glasses when handling the battery.
- Check all fuel lines for tightness and wear on a regular basis. Tighten or repair them as needed.
- To reduce the hazard of fire, keep the battery compartment, engine, and muffler areas free of grass, leaves, and excessive grease.
- Do not touch the engine, the muffler, or other exhaust components while the engine is running or immediately after stopping the engine. These areas may be hot enough to cause a burn.
- Allow the engine to cool before storing and do not store near an open flame.
- Do not change the engine governor settings or over-speed the engine. Operating engine at excessive speed may increase the hazard of personal injury.
- Springs may contain stored energy. Use caution when disengaging or removing springs and/or spring loaded components.
- An obstruction or blockage in a drive system or moving/rotating parts may cause a buildup of stored energy. When the obstruction or blockage is removed, the drive system or moving/rotating parts may move suddenly. Do not attempt to remove an obstruction or blockage with your hands. Keep hands, feet, and clothing away from all power-driven parts.
- Dispose of all fluids in accordance with local laws.

### Fuel Safety



- To avoid personal injury or property damage, use extreme care in handling gasoline. Gasoline is extremely flammable and the vapors are explosive.
- Do not refuel machine while smoking or at a location near flames or sparks.
- Always refuel the machine outdoors.
- Do not store machine or fuel container indoors where fumes or fuel can reach an open flame, spark, or pilot light.
- Only store fuel in an approved container. Keep out of reach of children.
- Never fill containers inside a vehicle or on a truck or trailer bed with a plastic liner. Always place containers on the ground away from your vehicle before filling.
- Remove machine from the truck or trailer and refuel it on the ground. If this is not possible, refuel the machine using a portable container, rather than from a fuel dispenser nozzle.
- Never remove fuel cap or add fuel with the engine running. Allow engine to cool before refueling.
- Never remove fuel cap while on a slope. Only remove when parked on a level surface.
- Replace all fuel tank and container caps securely.

# SAFETY



## General Safety Procedures for Ventrac Power Units, Attachments, & Accessories



### Fuel Safety (continued)

- Do not overfill fuel tank. Only fill to bottom of fuel neck, do not fill fuel neck full. Overfilling of fuel tank could result in engine flooding, fuel leakage from the tank, and/or damage to the emissions control system.
- If fuel is spilled, do not attempt to start the engine. Move the power unit away from the fuel spill and avoid creating any source of ignition until fuel vapors have dissipated.
- If the fuel tank must be drained, it should be drained outdoors into an approved container.
- Dispose of all fluids in accordance with local laws.
- Check all fuel lines for tightness and wear on a regular basis. Tighten or repair them as needed.
- The fuel system is equipped with a shut-off valve. Shut off the fuel when transporting the machine to and from the job, when parking the machine indoors, or when servicing the fuel system.

### Hydraulic Safety

- Make sure all hydraulic connections are tight and all hydraulic hoses and tubes are in good condition. Repair any leaks and replace any damaged or deteriorated hoses or tubes before starting the machine.
- Hydraulic leaks can occur under high pressure. Hydraulic leaks require special care and attention.
- Use a piece of cardboard and a magnifying glass to locate suspected hydraulic leaks.



- Keep body and hands away from pinhole leaks or nozzles that eject high pressure hydraulic fluid. Hydraulic fluid escaping under high pressure can penetrate the skin causing serious injury, leading to severe complications and/or secondary infections if left untreated. If hydraulic fluid is injected into the skin, seek immediate medical attention no matter how minor the injury appears.

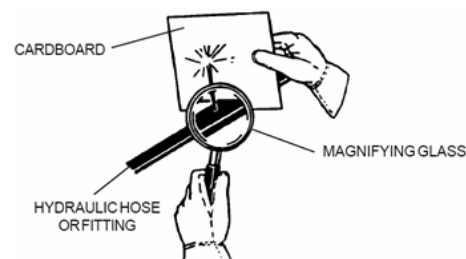

- Hydraulic system may contain stored energy. Before performing maintenance or repairs on the hydraulic system, remove attachments, engage parking brake, disengage weight transfer system (if equipped), shut off engine, and remove ignition key. To relieve pressure on the auxiliary hydraulic system, shut off the power unit engine and move the hydraulic control lever left and right before disconnecting the auxiliary hydraulic quick couplers.
- Dispose of all fluids in accordance with local laws.

# SAFETY

---



## EB480 Safety Procedures



- Know where and how deep any gas, water, and electrical lines are buried. Avoid operating in questionable areas.
- Aerator tines are sharp. Wear leather gloves when working with aerator tines.
- Prior to aerating, clear the work area of any sticks, rocks, and other debris and hazards.
- Do not use front hitch hydraulic down pressure to force tines to penetrate hard dry ground.
- Do not operate with more than eight Ventrac weights or 340 pounds (154 Kg) installed on the aerator.

# GENERAL OPERATION

## Daily Inspection

### WARNING

Always set the parking brake, shut off power unit engine, remove the ignition key, and ensure all moving parts have come to a complete stop before inspecting components, or attempting any repair or adjustment.

1. Park machine on a level surface, with the engine shut off and all fluids cold.
2. Perform a visual inspection of both the power unit and the aerator. Look for loose or missing hardware, damaged components, or signs of wear.
3. Inspect the tines for damage and loose bolts. Service as required.
4. Refer to the power unit operator's manual. Check the power unit's engine oil, hydraulic oil, cooling system, tire pressure, and fuel level. Add fluid or service as required.
5. Test the power unit's operator safety interlock system\*.

## Attaching

1. Drive the power unit slowly forward into the hitch arms of the aerator. Align the lift arms of the power unit with the aerator hitch arms by raising or lowering the front hitch and complete the engagement.
2. Once completely engaged, close the front hitch locking lever.\*
3. Raise the aerator, engage the parking brake, and move the storage stands up to the operating position.

## Detaching

1. Park the power unit on a level surface and set the parking brake.\*
2. Move the storage stands down to the storage position and lower the aerator to the ground.
3. Open the front hitch locking lever.\*
4. Slowly back the power unit away from the aerator. A side to side movement of the steering wheel may aid disengagement.

## Operating Procedures

If the power unit is equipped with a weight transfer system\*, it must be disengaged prior to aerating. Ground must be thoroughly irrigated prior to aerating to ensure proper penetration of the aerator tines. Additional weight may be added for easier penetration of aerator tines.

### CAUTION

Do not use front hitch hydraulic down pressure to force tines to penetrate hard dry ground. Severe damage to aerator tines and frame may result.

Do not use more than eight Ventrac weights or 340 pounds (154 Kg) in an attempt to force tines to penetrate hard dry ground. Severe damage to aerator tines and frame may result.

Lower the aerator until the tines engage the ground. Place the primary SDLA lever\* in the float position.

### CAUTION

When aerating, always operate with the power unit's primary SDLA lever\* in the float position.

Drive the power unit forward at speeds which are safe (power unit stability and steering ability are maintained) and comfortable for the operator. Aerating should always be done in a straight line.

At the end of the work area, stop the power unit and raise the aerator out of the ground. Do not turn with the aerator tines in contact with the ground.

### CAUTION

Always lift the aerator so the tines are completely clear of the ground before turning.

Never reverse the power unit direction with the aerator tines engaged with the ground.

Severely compacted areas may need to be aerated several times in thirty degree cross section patterns.

### CAUTION

Failure to follow operating instructions and the warnings and cautions in the safety procedure and operating procedure sections can cause damage and/or premature failure of the aerator and its tines. Damage caused by failure to follow warnings and instructions will not be covered by warranty.

Due to the nature of aerating and the potential of striking hidden objects such as stones and tree roots, bent or broken tines are not a consideration for warranty. Warranty for tines will only apply when there is a proven defect from the manufacturer's specifications.

\* Refer to power unit operator's manual for operation of power unit controls.

# SERVICE

## WARNING

Always set the parking brake, shut off power unit engine, remove the ignition key, and ensure all moving parts have come to a complete stop before inspecting components or attempting any repair or adjustment.



## Attention

If any component requires replacement, use only original Ventrac replacement parts.

## Cleaning and General Maintenance

Rust-free tines penetrate the ground easier, with less weight and power requirements. Keep the tines cleaned and oiled to help maximize the performance of the aerator.

For best results, and to maintain the finish of the aerator, clean or wash the aerator and the aerator tines after each use. It is especially important to clean coring tines, making sure the core holes in the tines are free of any soil.

## CAUTION

Coring tines must be cleaned after every use, making sure the core holes in the tines are free of any soil. If soil is allowed to harden in the core holes in the tines, the tines may bend or break during subsequent usage.

If the aerator will not be used for more than one day, clean the tines and then oil the tines using an environmentally friendly vegetable or corn oil.

## Lubrication

Grease the reel hubs daily, or after every eight hours of operation using a lithium complex NLGI #2 type grease. Do not over grease or the bronze bushings could be forced out of the hubs. Stop greasing at the first sign of resistance from the grease gun lever or when grease is observed around the shaft.

Wipe off any excess grease.

## Storage

### Preparing the aerator for Storage

1. Clean the aerator frame.
2. Clean and oil the aerator tines.
3. Inspect the aerator tines for damage.
4. Inspect for loose or missing hardware.
5. Inspect safety decals. Replace any safety decals that are faded, illegible, or missing.
6. Grease the reels, following the instructions in the lubrication section.
7. Wipe off all excess grease.

### Removing the Aerator from Storage

1. Clean the aerator to remove any accumulated dust or debris.
2. Inspect the aerator as instructed in the daily inspection section of this manual.
3. Test the aerator to ensure all components are working properly.

# SPECIFICATIONS

---

## Dimensions

Overall Height . . . . .	26-1/4 inches (66.7 cm)
Overall Length . . . . .	30 inches (76.2 cm)
Overall Width . . . . .	54 inches (137.2 cm)
Working Width . . . . .	48 inches (122 cm)
Weight . . . . .	240 pounds (109 kg)
Coring Tine Length . . . . .	5-1/2 inches (14 cm)
Open Spoon Tine Length . . . . .	5-1/2 inches (14 cm)
Slitter/Slicer Tine Length. . . . .	5-3/8 inches (13.7 cm)

# PARTS

## ILLUSTRATED DRAWING Main Frame & Shields

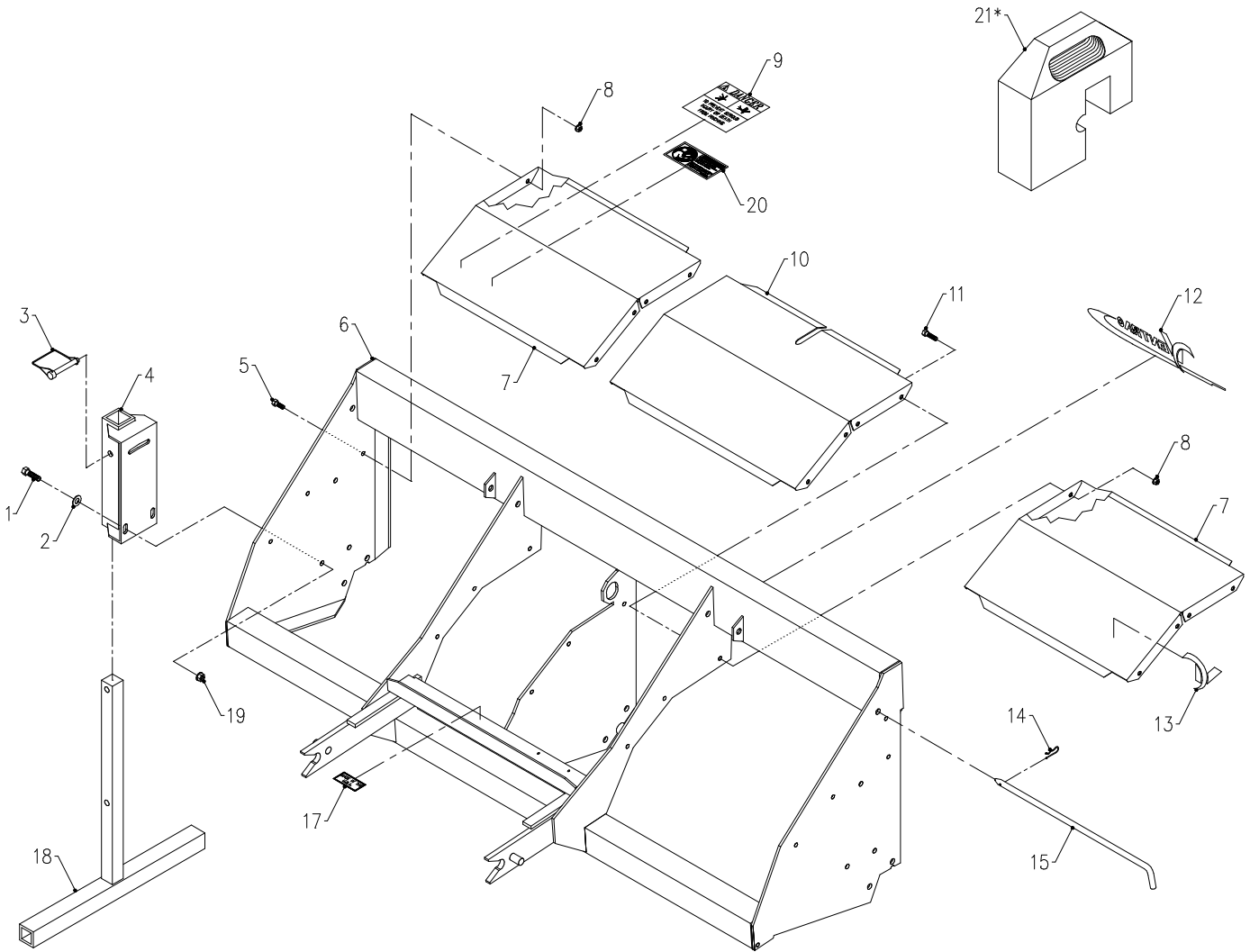



# PARTS

## Main Frame & Shields

REF.	PART NO.	DESCRIPTION	QTY.
1	90.0506	.BOLT, 5/16-18 USS X 3/4	6
2	95.05	.WASHER, FLAT 5/16 SAE	6
3	03.0003	.PIN, SAFETY SNAP 3/8 X 2 1/2	2
4	64.1059	.BRACKET, STAND SUPPORT/MT	2
5	99.SF0405-1	.BOLT, SMF 1/4-20 X 5/8	6
6	62.0962	.FRAME, MAIN	1
7	60.0857	.SHIELD, L&R ROTOR COVER	2
8	99.SF04	.NUT, SRF 1/4-20 USS	12
9	00.0102	.DECAL, DANGER-PINCHING HAZARD	1
10	60.0858	.SHIELD, CENTER ROTOR COVER	1
11	99.SF0406	.BOLT, SRF 1/4-20 X 3/4	6
12	00.0189	.DECAL, VENTRAC ORBITAL	1
13	00.0192	.DECAL, V-DECAL DIE CUT BLUE	1
14	02.HP0416	.HAIRPIN, 1/8 X 2	2
15	42.0457	.ROD, WEIGHT RETAINER	2
17	00.0100	.DECAL, MADE IN USA	1
18	62.0963	.STAND, PROP	2
19	99.SF05	.NUT, SRF 5/16-18 USS	6
20	00.0217	.DECAL, WARNING READ OWNERS MAN	1
21	47.0115*	.WEIGHT, SUITCASE- 42 LBS W/BOX	8

\*This item is an optional accessory that must be purchased separately. Up to eight Ventrac weights may be added to the aerator frame.

# PARTS

## ILLUSTRATED DRAWING

### Rotor Shaft, Reels, & Tines Kits (Serial # 1001-1075)

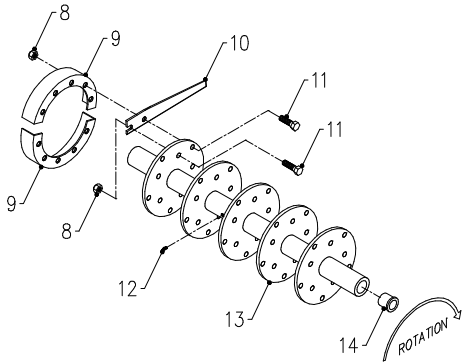

SLITTER TINE KIT # 70.8018

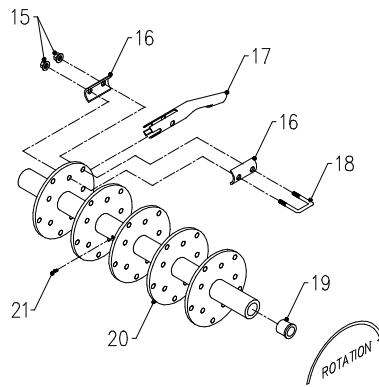

CORING TINE KIT # 70.8019

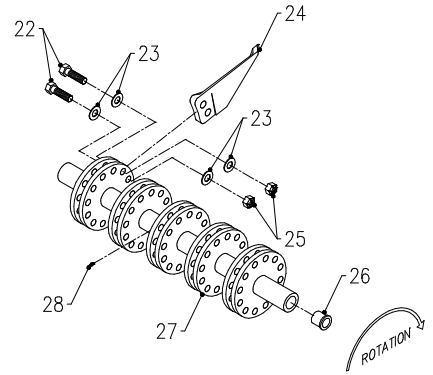

RACTURE TINE KIT # 70.8017

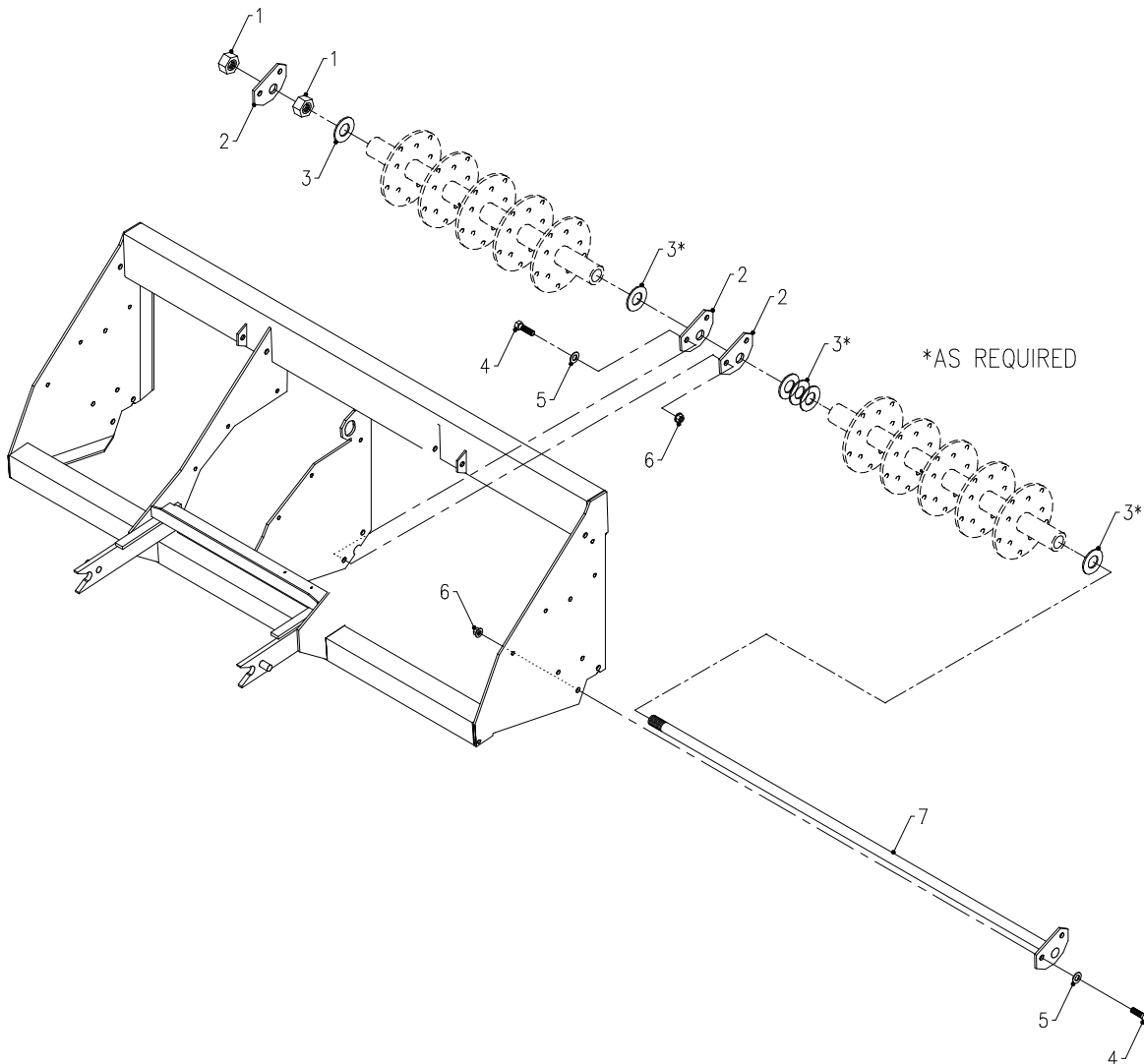

# PARTS

## Rotor Shaft, Reels, & Tine Kits (Serial # 1001-1075)

REF.	PART NO.	DESCRIPTION	QTY.
1	92.12	NUT, 3/4-10 USS	2
2	64.1061	ANCHOR, ROTOR SHAFT EB	3
3	95.12	WASHER, FLAT 3/4 SAE	5*
4	90.0608	BOLT, 3/8-16 USS X 1	6
5	95.06	WASHER, FLAT 3/8 SAE	6
6	99.SF06	NUT, SRF 3/8-16 USS	6
7	80.0332	SHAFT, ROTOR EB	1
8	99.A06N	LOCKNUT, NYLON 3/8-16	100
9	47.0223	DISK, SLITTER/SLICER	20
10	79.0068	TINE, SLITTER/SLICER	50
11	90.0608	BOLT, 3/8-16 USS X 1	100
12	29.GF0001	GREASE FTG, 1/4 SAE ST	2
13	80.0334	REEL, TINE CT & SS EB480	2
14	85.B0078	BUSHING, BRONZE BANNERMAN	4
15	99.E0071	NUT, LOCK 3/8"-16 FLANGE	100
16	79.0069-1	SADDLE, BRACE FOR CORE TINE	100
17	79.0069	TINE, 3/4" CLOSED SPOON	50
18	11.0060	U-BOLT, 3/8-16 1-1/8 ID SQ	50
19	85.B0078	BUSHING, BRONZE BANNERMAN	4
20	80.0334	REEL, TINE CT & SS EB480	2
21	29.GF0001	GREASE FTG, 1/4 SAE ST	2
22	91.0816	BOLT, 1/2-20 SAE X 2	80
23	95.05	WASHER, FLAT 5/16 SAE	160
24	79.0067	TINE, FRACTURE	40
25	99.A08NF	LOCKNUT, STOVER 1/2-20 SAE	80
26	85.B0078	BUSHING, BRONZE BANNERMAN	4
27	80.0333	REEL, TINE FT EB480	2
28	29.GF0001	GREASE FTG, 1/4 SAE ST	2

\*as required

# PARTS

## ILLUSTRATED DRAWING

### Rotor Shaft, Reels, & Tines Kits (Serial # 1076-)

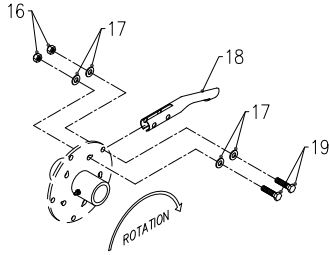

TEAR DROP HOLE SHOULD POINT IN THE DIRECTION OF ROTATION

3/4" CORE TINE KIT # 70.8070

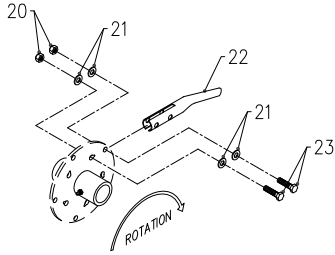

TEAR DROP HOLE SHOULD POINT IN THE DIRECTION OF ROTATION

3/4" OPEN SPOON TINE KIT # 70.8068

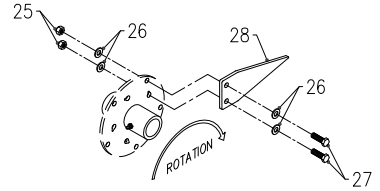

TEAR DROP HOLE SHOULD POINT IN THE OPPOSITE DIRECTION OF ROTATION

SLITTER/SLICER TINE KIT # 70.8069

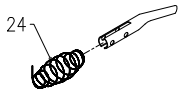

OPTIONAL SPRING  
KIT # 70.8071  
FOR CORE TINE &  
OPEN SPOON TINE

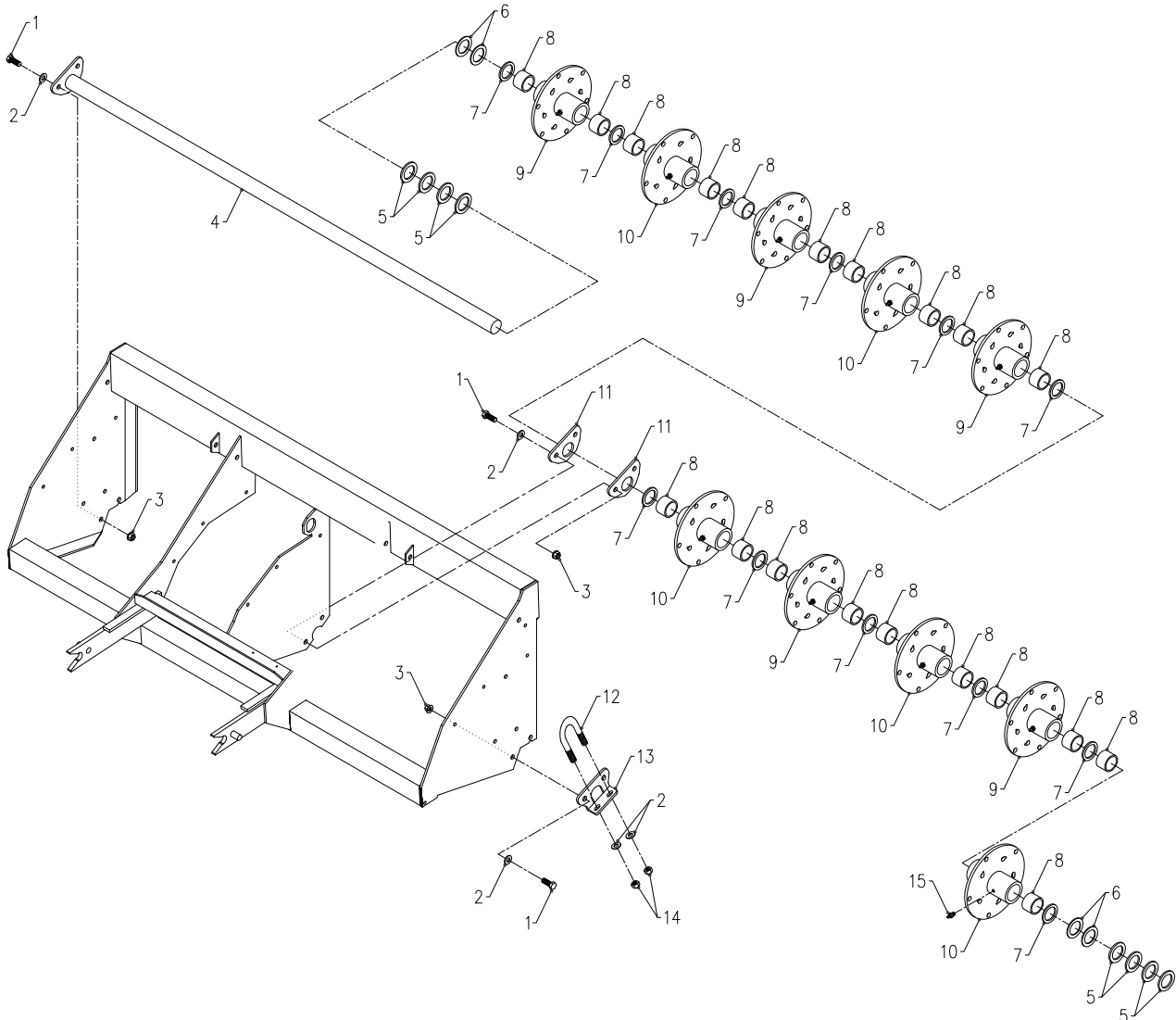

# PARTS

## Rotor Shaft, Reels, & Tine Kits (Serial # 1076-)

REF.	PART NO.	DESCRIPTION	QTY.
1	90.0608	.BOLT, 3/8-16 USS X 1	6
2	95.06	.WASHER, FLAT 3/8 SAE	8
3	99.SF06	.NUT, SRF 3/8-16 USS	6
4	80.0368	.SHAFT, ROTOR	1
5	99.B0024	.WASHER, MACH 1 1/4 10GA.	8*
6	99.B0078	.WASHER, MACH 1 1/4 14 GA.	6*
7	99.B0094	.WASHER, BRONZE THRUST	12
8	85.B0083	.BUSHING, BRONZE SLEEVE	20
9	53.0123	.HUB, 6 TINE ROTOR	5
10	53.0122	.HUB, 5 TINE ROTOR	5
11	64.1281	.PLATE, ROTOR SHAFT MOUNT	2
12	11.0064	.U-BOLT, 3/8-16 PIPE SIZE 3/4"	1
13	64.1282	.CLAMP, ROTOR SHAFT	1
14	99.A06	.LOCKNUT, STOVER 3/8-16 USS	2
15	29.GF0001	.GREASE FTG, 1/4 SAE ST	10
16	99.A06	.LOCKNUT, STOVER 3/8-16 USS	110
17	95.06	.WASHER, FLAT 3/8 SAE	220
18	79.0069	.TINE, 3/4" CLOSED SPOON	55
19	90.0612	.BOLT, 3/8-16 USS X 1 1/2	110
20	99.A06	.LOCKNUT, STOVER 3/8-16 USS	110
21	95.06	.WASHER, FLAT 3/8 SAE	220
22	79.0078	.TINE, 3/4" OPEN SPOON	55
23	90.0612	.BOLT, 3/8-16 USS X 1 1/2	110
24	41.0082	.SPRING, CORING TINE	55
25	99.A06	.LOCKNUT, STOVER 3/8-16 USS	110
26	95.06	.WASHER, FLAT 3/8 SAE	220
27	90.0610	.BOLT, 3/8-16 USS X 1 1/4	110
28	78.0061	.TINE, SLICING 1/4 X 7-1/4"	55

\*as required

# WARRANTY



## LIMITED WARRANTY - VENTRAC COMMERCIAL EQUIPMENT

Venture Products, Inc., (henceforth referred to as V.P.I.) warrants on the terms and conditions herein, that it will repair, replace, or adjust any part manufactured by Venture Products Inc., and found by Venture Products, Inc., to be defective in material and/or workmanship during the applicable warranty term.

All Ventrac commercial equipment purchased and registered on or after January 1, 2019 will carry a 2-year commercial warranty. The warranty period begins on the date of original customer purchase:

<b>Ventrac Commercial Equipment</b>	<b>Warranty Term</b>
2100 SSV & Attachments	2-year
3000 Series Tractors & Attachments	2-year
4000 Series Tractors & Attachments	2-year

All Ventrac add-on kits and accessories such as: 3-point hitch, 12V front & rear power outlets, foot pedal, dual wheel kit, etc., will be covered under the above warranty periods provided they are installed by an Authorized Ventrac Dealer. This warranty may be transferred and will carry the remainder of the warranty starting from the original purchase/registration date with the dealership and/or V.P.I.

The engine warranty is covered by its respective engine manufacturer. Please refer to the engine manufacturer's warranty statement that is included in the owner's manual.

For warranty consideration on Ventrac commercial equipment, including any defective part, must be returned to an Authorized Ventrac Dealer within the warranty period. The warranty shall extend to the cost to repair or replace (as determined by V.P.I.) the defective part. The expense of pickup and delivery of equipment, service call drive time or any transportation expense incurred for warranty repair is the sole responsibility of the owner and is not covered under warranty by Ventrac and/or V.P.I. Ventrac and V.P.I.'s responsibility in respect to claims is limited to making the required repairs or replacements, and no claim of breach of warranty shall be cause for cancellation or rescission of the contract of sale of any Ventrac equipment. Proof of purchase may be required by the dealer to substantiate any warranty claim. Only warranty work performed and submitted by an Authorized Ventrac Dealer may be eligible for warranty credit.

This warranty extends only to Ventrac commercial equipment operated under normal conditions and properly serviced and maintained. The warranty expressly does NOT cover: (a) any defects, damage or deterioration due to normal use, wear and tear, or exposure; (b) normal maintenance services, such as cleaning, lubrication, oil change; (c) replacement of service items, such as oil, lubricants, spark plugs, belts, rubber hoses, bearings or other items subject to normal service replacement; (d) damage or defects arising out of, or relating to abuse, misuse, neglect, alteration, negligence or accident; (e) repair or replacement arising from operation of, or use of the equipment which is not in accordance with operating instructions as specified in the operator's manual or other operational instructions provided by V.P.I.; (f) repair or replacement arising as a result of any operation from Ventrac equipment that has been altered or modified so as to, in the determination of V.P.I., adversely affect the operation, performance or durability of the equipment or that has altered, modified or affected the equipment so as to change the intended use of the product; (g) repair or replacement necessitated by the use of parts, accessories or supplies, including gasoline, oil or lubricants, incompatible with the equipment or other than as recommended in the operator's manual or other operational instructions provided by V.P.I.; (h) repairs or replacements resulting from parts or accessories which have adversely affected the operation, performance or durability of the equipment; or (i) damage or defects due to or arising out of repair of Ventrac equipment by person or persons other than an authorized Ventrac service dealer or the installation of parts other than genuine Ventrac parts or Ventrac recommended parts.

# WARRANTY

---



## LIMITED WARRANTY - VENTRAC COMMERCIAL EQUIPMENT

The sole liability of V.P.I. with respect to this warranty shall be the repair and replacement as set forth herein. V.P.I. shall have no liability for any other cost, loss, or damage. In particular V.P.I shall have no liability or responsibility for: (i) expenses relating to gasoline, oil, lubricants; (ii) loss, cost or expense relating to transportation or delivery of turf equipment from the location of owner or location where used by owner to or from any Authorized Ventrac Dealer; (iii) travel time, overtime, after hours' time or other extraordinary repair charges or charge relating to repairs or replacements outside of normal business hours at the place of business of an Authorized Ventrac Dealer; (iv) rental of like or similar replacement equipment during the period of any warranty repair or replacement work; (v) any telephone or telegram charges; (vi) loss or damage to person or property other than that covered by the terms of this warranty; (vii) any claims for lost revenue, lost profit or additional cost or expense incurred as a result of a claim of breach of warranty; or (viii) attorney's fees.

The remedies of buyer set forth herein are exclusive and are in lieu of all other remedies. The liability of V.P.I., whether in contract, tort, under any warranty, or otherwise, shall not extend beyond its obligation as set forth herein. V.P.I. shall not be liable for cost of removal or installation nor shall V.P.I. be responsible for any direct, indirect, special or consequential damages of any nature. In no event shall V.P.I. be liable for any sum in excess of the price received for the goods for which liability is claimed.

There are no representations or warranties which have been authorized to the buyer of the Ventrac commercial equipment other than set forth in this warranty. Any and all statements or representations made by any seller of this equipment, including those set forth in any sales literature or made orally by any sales representative, are superseded by the terms of this warranty. Any affirmation of fact or promise made by V.P.I. or any of its representatives to the buyer which relates to the goods that are the subject to this warranty shall not be regarded as part of the basis of the bargain and shall not be deemed to create any express warranty that such goods shall conform to the affirmation or promise.

No employee, distributor, or representative is authorized to change the foregoing warranties in any way or grant any other warranty on behalf of V.P.I.

Some states do not allow limitations on how long an implied warranty lasts or allow the exclusion on limitation of incidental or consequential damages, so the above limitation or exclusion may not apply to you.

This warranty gives you specific legal rights, and you may also have other rights which vary from state to state.

This warranty applies to all Ventrac commercial equipment sold by Venture Products Inc.