



OPERATOR'S MANUAL & PARTS DRAWINGS

BRINE SPRAY SYSTEM

MODEL NB200

SERIAL # AA01001 - AA01040





500 Venture Drive
Orrville, OH 44667
www.ventrac.com

To the Owner Contact Information and Product Identification

If you need to contact an authorized Ventrac dealer for information on servicing your product, always provide the product model and serial numbers.

Please fill in the following information for future reference. See the picture(s) below to find the location of the identification numbers. Record them in the spaces provided.

Date of Purchase: _____

Dealer: _____

Dealer Address: _____

Dealer Phone Number: _____

Dealer Fax Number: _____

Model # (A): _____

Serial # (B): _____

Affix Part/Serial Number label here.

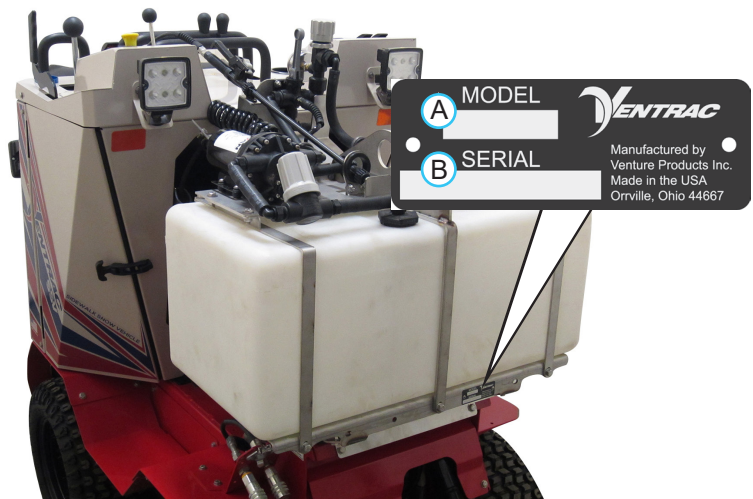

Venture Products Inc. reserves the right to make changes in design or specifications without obligation to make like changes on previously manufactured products.

TABLE OF CONTENTS

INTRODUCTION	PAGE 5
Product Description.....	5
Why Do I Need an Operator’s Manual?	5
Using Your Manual	6
Manual Glossary	6
SAFETY	PAGE 7
General Safety Procedures.....	7
Training Required.....	7
Personal Protective Equipment Requirements	7
Operation Safety	7
Preventing Accidents.....	8
Keep Riders Off.....	8
Operating On Slopes.....	9
Roadway Safety	9
Truck Or Trailer Transport	9
Maintenance.....	10
Fuel Safety	10
Hydraulic Safety	11
NB200 Safety Procedures.....	12
SETUP	PAGE 13
Setup Instructions for Brine System.....	13
OPERATIONAL CONTROLS	PAGE 18
Operational Control Locations.....	18
Pump Switch (A)	18
On/Off Control Valve (B)	18
Pressure Regulating Valve (C).....	18
Hand Held Spray Gun (D).....	18
Outer Spray Nozzle Valves (E)	18
GENERAL OPERATION	PAGE 19
Daily Inspection.....	19
Operating Procedure.....	19
Spraying Width.....	19
Pressure Regulation.....	19
Brine System Pressure Settings	19
SERVICE	PAGE 20
Cleaning and General Maintenance.....	20
Cleaning the Filter Element.....	20
Cleaning the Nozzles	20
Draining and Flushing the Brine System.....	21
Storage Between Snow Events.....	21
Removal of Brine Tank	22

TABLE OF CONTENTS

SPECIFICATIONS	PAGE 23
Dimensions	23
Features	23
PARTS	PAGE 24
Tank Base Frame Mount	24
Brine Tank & Mounting Straps.....	26
Pump & Pump Mount, Spray Gun & Mount, Pump Switch	28
Brine Control Valves, Intake, & Return Hose Circuit.....	30
Rear Supply Hose, Center Nozzle Hose, & Center Nozzles.....	32
Left & Right Outer Nozzles.....	34
WARRANTY	PAGE 36

INTRODUCTION



Venture Products Inc. is pleased to provide you with your new Ventrac brine system! We hope that Ventrac equipment will provide you with a ONE Tractor Solution.

Product Description

The NB200 Brine system features a 20 gallon (75.7 liter) tank, rear mounted nozzles, and a hand held spray gun. The nozzles distribute brine in a 36 - 48 inch (91.4 - 122 cm) wide spray pattern. The spray gun is useful for accessing hard to reach areas and features a coiled hose for easy storage and operation.

Why Do I Need an Operator's Manual?

This manual has been created to help you gain the important knowledge of what is needed to safely operate, maintain, and service your machine. It is divided into sections for convenient reference of the appropriate section.

You must read and understand the operator's manual for each piece of Ventrac equipment you own. Reading the operator's manual will help you become familiar with each specific piece of equipment. Understanding the operator's manual will help you, as well as others, avoid personal injury and/or damage to the equipment. Keep this manual with the machine at all times. The manual should remain with the machine even if it is sold. If this manual becomes damaged or unreadable, it should be replaced immediately. Contact your local Ventrac dealer for a replacement.

When using a Ventrac attachment, be sure to read and follow the safety and operating instructions of both the power unit and the attachment being used to ensure the safest operation possible.

The information in this manual provides the operator with the safest procedures to operate the machine while getting the maximum use out of the unit. Failure to follow the safety precautions listed in this manual may result in personal injury and/or damage to the equipment.

INTRODUCTION

Using Your Manual

Throughout this manual, you will encounter special messages and symbols that identify potential safety concerns to help you as well as others avoid personal injury or damage to the equipment.

SYMBOL DEFINITIONS



ATTENTION

This symbol identifies potential health and safety hazards. It marks safety precautions. Your safety and the safety of others is involved.

There are three signal words that describe the level of safety concern: Danger, Warning, and Caution. Safety should always be the #1 priority when working on or operating equipment. Accidents are more likely to occur when proper operating procedures are not followed or inexperienced operators are involved.

Note: Right-Hand and Left-Hand orientations may be referred to at different places throughout this manual. Right-Hand and Left-Hand is determined as if sitting on the power unit seat facing forward.

SIGNAL WORD DEFINITIONS

⚠ DANGER

Indicates an imminently hazardous situation which, if not avoided, will result in death or serious injury. This signal word is limited to the most extreme cases.

⚠ WARNING

Indicates a potentially hazardous situation which, if not avoided, could result in death or serious injury.

⚠ CAUTION

Indicates a potentially hazardous situation which, if not avoided, may result in minor or moderate injury and/or property damage. It may also be used to alert against unsafe practices.

Manual Glossary

Power Unit A Ventrac tractor or other Ventrac engine powered device that may be operated by itself or with an attachment or accessory.

Attachment A piece of Ventrac equipment that requires a Power Unit for operation.

Accessory A device that attaches to a Power Unit or Attachment to extend its capabilities.

Machine Describes any "Attachment" or "Accessory" that is used in conjunction with a power unit.

SAFETY



General Safety Procedures for Ventrac Power Units, Attachments, & Accessories



Training Required

- The owner of this machine is solely responsible for properly training the operators.
- The owner/operator is solely responsible for the operation of this machine and prevention of accidents or injuries occurring to him/herself, other people, or property.
- Do not allow operation or service by children or untrained personnel. Local regulations may restrict the age of the operator.
- Before operating this machine, read the operator's manual and understand its contents.
- If the operator of the machine cannot understand this manual, then it is the responsibility of this machine's owner to fully explain the material within this manual to the operator.
- Learn and understand the use of all controls.
- Know how to stop the power unit and all attachments quickly in the event of an emergency.



Personal Protective Equipment Requirements

It is the responsibility of the owner to be sure that the operators use the proper personal protective equipment while operating the machine. Required personal protective equipment includes, but is not limited to, the following list.



- Wear a certified ear protection device to prevent loss of hearing.
- Prevent eye injury by wearing safety glasses while operating the machine.
- Closed toe shoes must be worn at all times.
- Long pants must be worn at all times.
- When operating in dusty conditions, it is recommended that a dust mask be worn.

Operation Safety

- Inspect machine before operation. Repair or replace any damaged, worn, or missing parts. Be sure guards and shields are in proper working condition and are secured in place. Make all necessary adjustments before operating machine.
- Some pictures in this manual may show shields or covers opened or removed in order to clearly illustrate any instructions. Under no circumstance should the machine be operated without these devices in place.
- Alterations or modifications to this machine can reduce safety and could cause damage to the machine. Do not alter safety devices or operate with shields or covers removed.
- Before each use, verify that all controls function properly and inspect all safety devices. Do not operate if controls or safety devices are not in proper working condition.
- Check parking brake function before operating. Repair or adjust parking brake if necessary.
- Observe and follow all safety decals.
- All controls are to be operated from the operator's station only.
- Always wear a seat belt if the machine has a roll cage/bar installed and in upright position.
- Ensure the attachment or accessory is locked or fastened securely to the power unit before operating.
- Ensure that all bystanders are clear of the power unit and attachment before operating. Stop machine if someone enters your work area.
- Always be alert to what is happening around you, but do not lose focus on the task you are performing. Always look in the direction the machine is moving.
- Look behind and down before backing up to be sure of a clear path.
- If you hit an object, stop and inspect the machine. Make all necessary repairs before operating machine again.
- Stop operation immediately at any sign of equipment failure. An unusual noise can be a warning of equipment failure or a sign that maintenance is required. Make all necessary repairs before operating machine again.

SAFETY



General Safety Procedures for Ventrac Power Units, Attachments, & Accessories



Operation Safety (continued)

- If equipped with a high/low range feature, never shift between high and low range while on a slope. Always move the machine to level ground and engage the parking brake before shifting range.
- Do not leave machine unattended while it is running.
- Always park the machine on level ground.
- Always shut off engine when connecting attachment drive belt to the power unit.
- Never leave the operator's station without lowering the attachment to the ground, setting the parking brake, shutting off the engine, and removing the ignition key. Make sure all moving parts have come to a complete stop before dismounting.
- Never leave equipment unattended without lowering the attachment to the ground, setting the parking brake, shutting off the engine, and removing the ignition key.
- Only operate in well-lit conditions.
- Do not operate when there is a risk of lightning.
- Never direct the discharge of any attachment in the direction of people, buildings, animals, vehicles, or other objects of value.
- Never discharge material against a wall or obstruction. Material may ricochet back towards the operator.
- Use extra caution when approaching blind corners, shrubs, trees, or other objects that may obscure vision.
- Do not run the engine in a building without adequate ventilation.
- Do not touch the engine or the muffler while the engine is running or immediately after stopping the engine. These areas may be hot enough to cause a burn.
- Do not change the engine governor settings or over-speed the engine. Operating engine at excessive speed may increase the hazard of personal injury.
- To reduce the hazard of fire, keep the battery compartment, engine, and muffler areas free of grass, leaves, excessive grease, and other flammable materials.

Preventing Accidents



- Clear working area of objects that might be hit or thrown from machine.
- Keep people and pets out of working area.
- Know the work area well before operation. Do not operate where traction or stability is questionable.
- Reduce speed when you are operating over rough ground.
- Equipment can cause serious injury and/or death when improperly used. Before operating, know and understand the operation and safety of the power unit and the attachment being used.

- Do not operate machine if you are not in good physical and mental health, if you will be distracted by personal devices, or are under the influence of any substance which might impair decision, dexterity, or judgment.
- Children are attracted to machine activity. Be aware of children and do not allow them in the working area. Turn off the machine if a child enters the work area.

Keep Riders Off

- Only allow the operator on the power unit. Keep riders off.
- Never allow riders on any attachment or accessory.

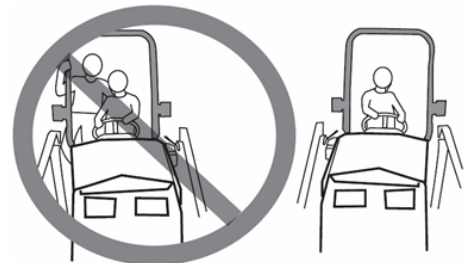

SAFETY



General Safety Procedures for Ventrac Power Units, Attachments, & Accessories



Operating On Slopes

- Slopes can cause loss-of-control and tip-over accidents, which can result in severe injury or death. Be familiar with the emergency parking brake, along with the power unit controls and their functions.
- If power unit is equipped with a fold down roll bar, it must be locked in the upright position when operating on any slope.
- Use low range (if equipped) when operating on slopes greater than 15 degrees.
- Do not stop or start suddenly when operating on slopes.
- Never shift between high and low range while on a slope. Always move the power unit to level ground and engage the parking brake before shifting range or placing the power unit in neutral.
- Variables such as wet surface and loose ground will reduce the degree of safety. Do not drive where machine could lose traction or tip over.
- Keep alert for hidden hazards in the terrain.
- Stay away from drop-offs, ditches, and embankments.
- Sharp turns should be avoided when operating on slopes.
- Pulling loads on hills decreases safety. It is the responsibility of the owner/operator to determine loads that can safely be controlled on slopes.
- Transport machine with attachment lowered or close to the ground to improve stability.
- While operating on slopes, drive in an up and down direction when possible. If turning is necessary while driving across slopes, reduce speed and turn slowly in the downhill direction.
- Assure a sufficient supply of fuel for continuous operation. A minimum of one-half tank of fuel is recommended.

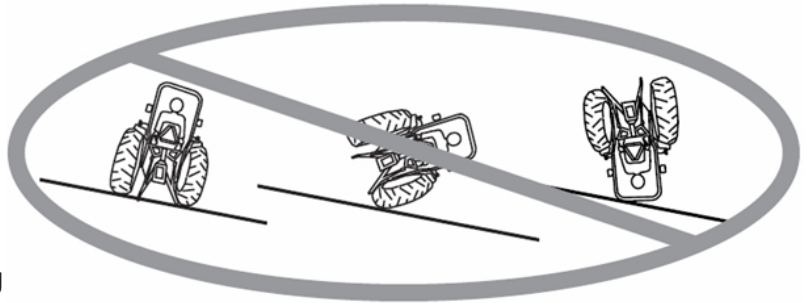

Roadway Safety

- Operate with safety lights when operating on or near roadways.
- Obey all state and local laws concerning operation on roadways.
- Slow down and be careful of traffic when operating near or crossing roadways. Stop before crossing roads or sidewalks. Use care when approaching areas or objects that may obscure vision.
- If there is doubt of safety conditions, discontinue machine operation until a time when operation can be performed safely.
- When operating near or on roadways, have a Slow Moving Vehicle Emblem clearly displayed.

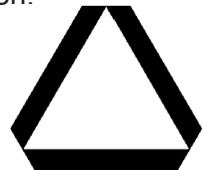

Truck Or Trailer Transport

- Use care when loading or unloading machine into a truck or trailer.
- Use full width ramps for loading machine into a truck or trailer.
- The parking brake is not sufficient to lock the machine during transport. Always secure the power unit and/or attachment to the transporting vehicle securely using straps, chains, cable, or ropes. Both front and rear straps should be directed down and outward from the machine.
- Shut off fuel supply to power unit during transport on truck or trailer.
- If equipped, turn the battery disconnect switch to the Off position to shut off electrical power.

SAFETY



General Safety Procedures for Ventrac Power Units, Attachments, & Accessories



Maintenance

- Keep all safety decals legible. Remove all grease dirt, and debris from safety decals and instructional labels.
- If any decals are faded, illegible, or missing, contact your dealer promptly for replacements.
- When new components are installed, be sure that current safety decals are affixed to the replacement components.
- If any component requires replacement, use only original Ventrac replacement parts.
- Always turn the battery disconnect to the Off position or disconnect the battery before performing any repairs. Disconnect the negative terminal first and the positive terminal last. Reconnect the positive terminal first and the negative terminal last.
- Keep all bolts, nuts, screws, and other fasteners properly tightened.
- Always lower the attachment to the ground, engage parking brake, shut off engine, and remove the ignition key. Make sure all moving parts have come to a complete stop before cleaning, inspection, adjusting or repairing.
- If the power unit, attachment, or accessory requires repairs or adjustments not instructed in the operator's manual, the power unit, attachment, or accessory must be taken to an authorized Ventrac dealer for service.
- Never perform maintenance on the power unit and/or attachment if someone is in the operator's station.
- Always use protective glasses when handling the battery.
- Check all fuel lines for tightness and wear on a regular basis. Tighten or repair them as needed.
- To reduce the hazard of fire, keep the battery compartment, engine, and muffler areas free of grass, leaves, and excessive grease.
- Do not touch the engine, the muffler, or other exhaust components while the engine is running or immediately after stopping the engine. These areas may be hot enough to cause a burn.
- Allow the engine to cool before storing and do not store near an open flame.
- Do not change the engine governor settings or over-speed the engine. Operating engine at excessive speed may increase the hazard of personal injury.
- Springs may contain stored energy. Use caution when disengaging or removing springs and/or spring loaded components.
- An obstruction or blockage in a drive system or moving/rotating parts may cause a buildup of stored energy. When the obstruction or blockage is removed, the drive system or moving/rotating parts may move suddenly. Do not attempt to remove an obstruction or blockage with your hands. Keep hands, feet, and clothing away from all power-driven parts.
- Dispose of all fluids in accordance with local laws.

Fuel Safety



- To avoid personal injury or property damage, use extreme care in handling gasoline. Gasoline is extremely flammable and the vapors are explosive.
- Do not refuel machine while smoking or at a location near flames or sparks.
- Always refuel the machine outdoors.
- Do not store machine or fuel container indoors where fumes or fuel can reach an open flame, spark, or pilot light.
- Only store fuel in an approved container. Keep out of reach of children.
- Never fill containers inside a vehicle or on a truck or trailer bed with a plastic liner. Always place containers on the ground away from your vehicle before filling.
- Remove machine from the truck or trailer and refuel it on the ground. If this is not possible, refuel the machine using a portable container, rather than from a fuel dispenser nozzle.
- Never remove fuel cap or add fuel with the engine running. Allow engine to cool before refueling.
- Never remove fuel cap while on a slope. Only remove when parked on a level surface.
- Replace all fuel tank and container caps securely.

SAFETY



General Safety Procedures for Ventrac Power Units, Attachments, & Accessories



Fuel Safety (continued)

- Do not overfill fuel tank. Only fill to bottom of fuel neck, do not fill fuel neck full. Overfilling of fuel tank could result in engine flooding, fuel leakage from the tank, and/or damage to the emissions control system.
- If fuel is spilled, do not attempt to start the engine. Move the power unit away from the fuel spill and avoid creating any source of ignition until fuel vapors have dissipated.
- If the fuel tank must be drained, it should be drained outdoors into an approved container.
- Dispose of all fluids in accordance with local laws.
- Check all fuel lines for tightness and wear on a regular basis. Tighten or repair them as needed.
- The fuel system is equipped with a shut-off valve. Shut off the fuel when transporting the machine to and from the job, when parking the machine indoors, or when servicing the fuel system.

Hydraulic Safety

- Make sure all hydraulic connections are tight and all hydraulic hoses and tubes are in good condition. Repair any leaks and replace any damaged or deteriorated hoses or tubes before starting the machine.
- Hydraulic leaks can occur under high pressure. Hydraulic leaks require special care and attention.
- Use a piece of cardboard and a magnifying glass to locate suspected hydraulic leaks.



- Keep body and hands away from pinhole leaks or nozzles that eject high pressure hydraulic fluid. Hydraulic fluid escaping under high pressure can penetrate the skin causing serious injury, leading to severe complications and/or secondary infections if left untreated. If hydraulic fluid is injected into the skin, seek immediate medical attention no matter how minor the injury appears.

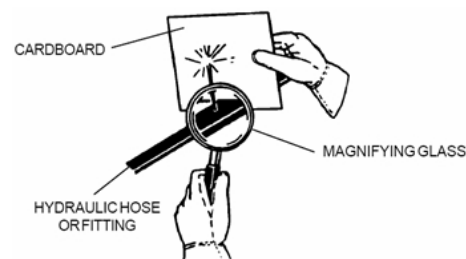

- Hydraulic system may contain stored energy. Before performing maintenance or repairs on the hydraulic system, remove attachments, engage parking brake, disengage weight transfer system (if equipped), shut off engine, and remove ignition key. To relieve pressure on the auxiliary hydraulic system, shut off the power unit engine and move the hydraulic control lever left and right before disconnecting the auxiliary hydraulic quick couplers.
- Dispose of all fluids in accordance with local laws.

SAFETY



NB200 Safety Procedures



- Brine tank frame must be properly secured to the power unit before operating.
- Do not point the spray gun at people or animals.
- Do not use any products containing petroleum or petroleum by-products, as they can cause damage to system components.
- Always turn off electrical power to the pump and shut off the power unit before performing maintenance or repairs on the brine system.
- Wear safety goggles or a face shield when servicing brine system hoses, nozzles, or spray wand.
- When using a commercial deicing solution, follow the manufacturer's recommendations for personal protective equipment and first aid procedures.
- If you are making your own salt brine solution, wear eye goggles or a full face shield and gloves when mixing the brine solution and when filling the brine tank. Avoid contact with eyes, skin, and clothing.
- Salt brine can cause irritation to the eyes and the skin. In case of eye contact, immediately flush eyes with plenty of water for 10 minutes. Seek medical attention if irritation persists. In case of skin contact, wash with mild soap and water.
- Ingestion of salt brine may cause nausea, vomiting, diarrhea, tissue irritation, fever, etc. If a large amount of salt brine is ingested, drink large amounts of water or milk. If any symptoms develop, seek immediate medical attention.
- In case of accidental release, follow the manufacturer's recommendations for containment and cleanup when using a commercial deicing solution. If using your own salt brine solution, rinse away small spills with water. For larger spills, contain the liquid and vacuum up or absorb the liquid for proper disposal. Rinse the spill area with water.

SETUP

Setup Instructions for Brine System

Installation Time (estimated)

2 hours



Attention

To prevent thread galling of stainless steel hardware, lubricate the bolt threads with a lithium complex NLGI #2 grease and use hand tools to tighten. Do not use air or electric power tools as this increases the potential of thread galling.

1. Park the power unit on a level surface.
2. Shut off the power unit's engine, engage the parking brake, and remove the key from the ignition.
3. Press the button on the battery disconnect switch.

WARNING

Failure to allow the engine and muffler to cool down sufficiently could result in severe burns from contact with hot engine components.

4. Allow the engine and muffler to cool completely before proceeding.
5. If the power unit is equipped with a storage basket kit, the storage basket must be removed.
6. Remove the operator cushion from the power unit.
7. Remove the pump belt drive cover from the engine frame on the power unit.
8. Remove the left center fender platform (A).

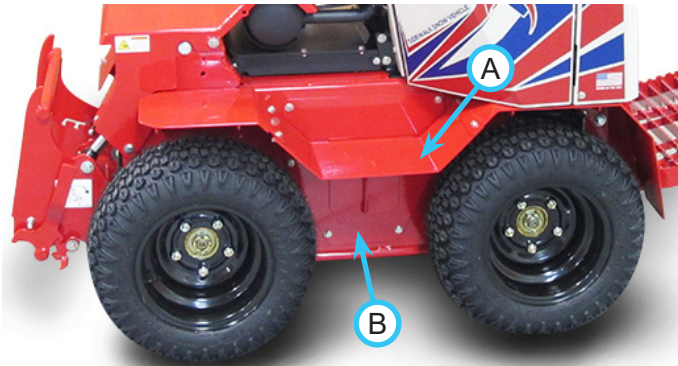

9. Remove the left frame side cover (B).
10. Remove the box of parts and hardware from the crate. Leave the brine tank assembly crated until the power unit has been fitted with brine nozzles and hoses.

11. Shape one of the 3/4" cushioned clamps so that the brine hose will slide through without pinching. Install the clamp (A) onto the left side of the main tower frame using the original hardware. Do not tighten.

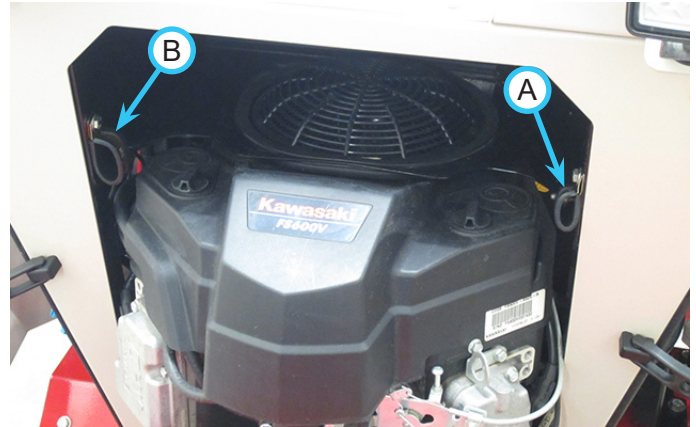

12. Shape one of the 3/4" cushioned clamps so that the pump harness connector will slide through. Install the clamp (B) on the right side of the main tower frame using the original hardware. Do not tighten.
13. Remove the nut from the bolt that fastens the left rear fender to the rear flange on the main frame. Install the left brine nozzle mount onto the bolt and loosely reinstall the nut.

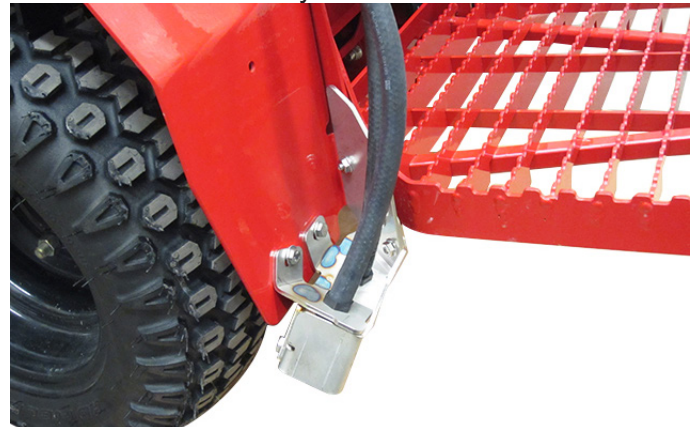

Fasten the brine nozzle mount to the left rear fender using 2) 1/4 x 3/4" bolts, washers, and flange nuts. Torque all three mounting bolts to 72 in-lbs (8 Nm).

SETUP

14. Remove the nut from the bolt that fastens the right rear fender to the rear flange on the main frame. Install the right brine nozzle mount onto the bolt and loosely reinstall the nut.

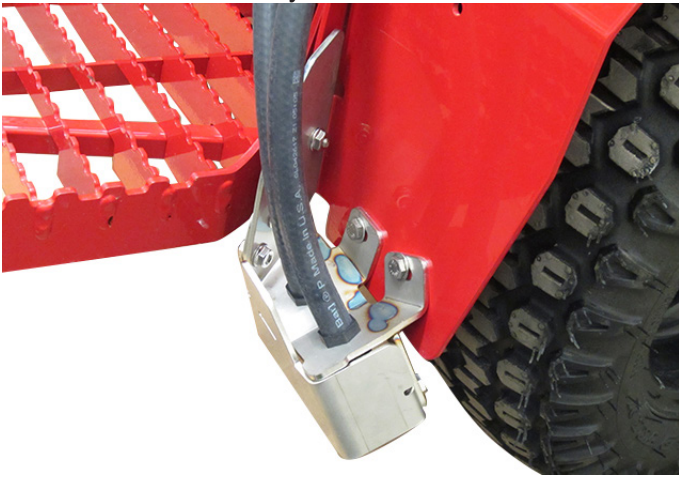

Fasten the brine nozzle mount to the right rear fender using 2) 1/4 x 3/4" bolts, washers, and flange nuts. Torque all three mounting bolts to 72 in-lbs (8 Nm).

15. Install the center brine nozzle mount onto the main frame in front of the operator platform using 2) 1/4 x 1" bolts, washers, and flange nuts.

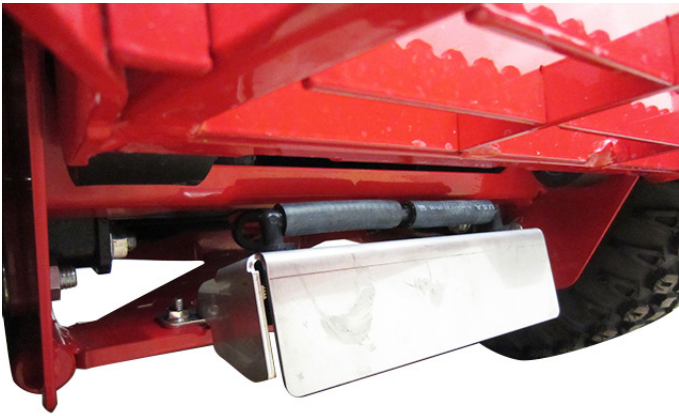

Torque to 72 in-lbs (8 Nm).

16. Locate the hose assembly with 3) hoses and a tee fitting.

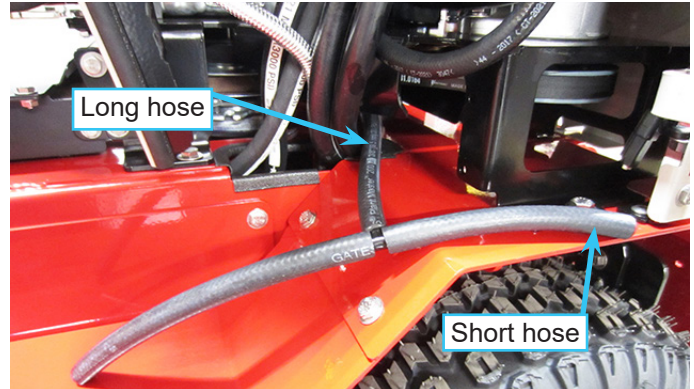
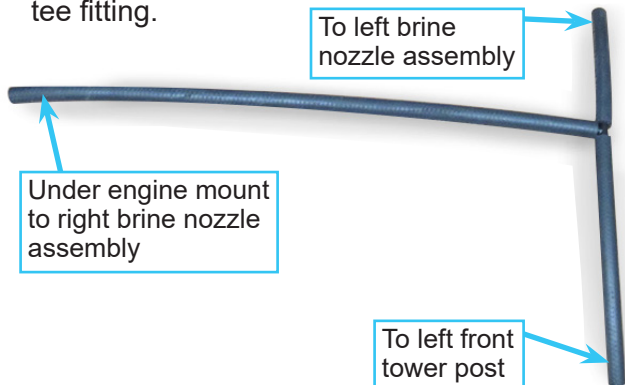

17. Route the long hose under the engine mount, in front of the fuel lines, through the slot in the frame, and back toward the right brine nozzle mount. Route the short hose back toward the left brine nozzle mount.

18. Pull the end of the long hose (C) out below the right rear cover and connect to the barbed fitting for the right brine nozzle assembly.

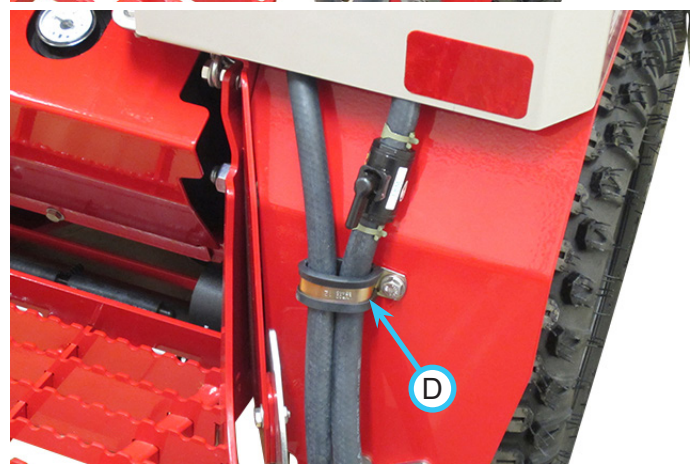
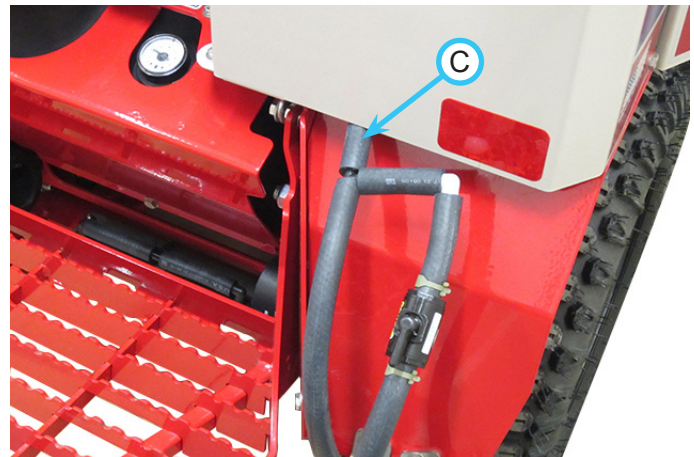

19. Push the hose connections up between the fender and rear cover. Place a 3/4" cushioned clamp (D) around the two hoses and fasten to the rear fender using a 1/4 x 1/2" bolt, washer, and flange nut. Torque to 72 in-lbs (8 Nm).

SETUP

- 20. Repeat steps 18 & 19 to connect the short hose to the left brine nozzle assembly.
- 21. Place the hose retainer bracket over the hose that runs from left to right under the engine mount. Ensure the hose is captured by all three hooks on the bracket.

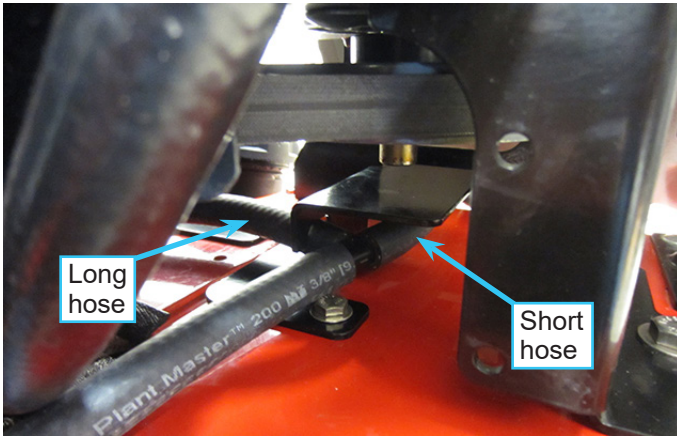

Fasten the bracket to the frame using 2) 1/4 x 3/4" bolts, washers, and flange nuts. Torque to 72 in-lbs (8 Nm).

- 22. Install the rubber grommet (E) into the hole in the main frame cross plate.

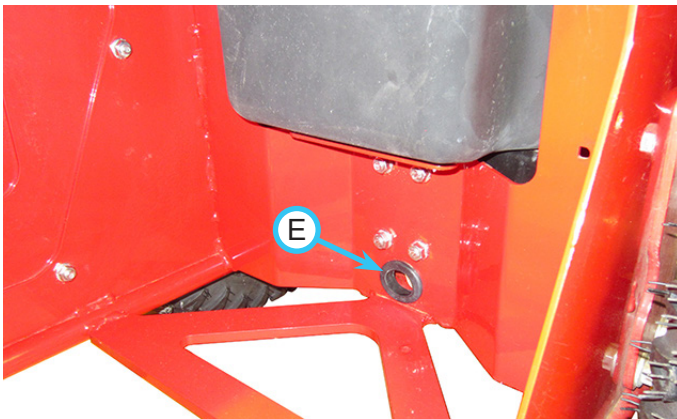

- 23. Locate the hose with a Tee fitting in one end. Route the end without the fitting down through the cutout for the hydraulic hoses in the left side of the main frame.

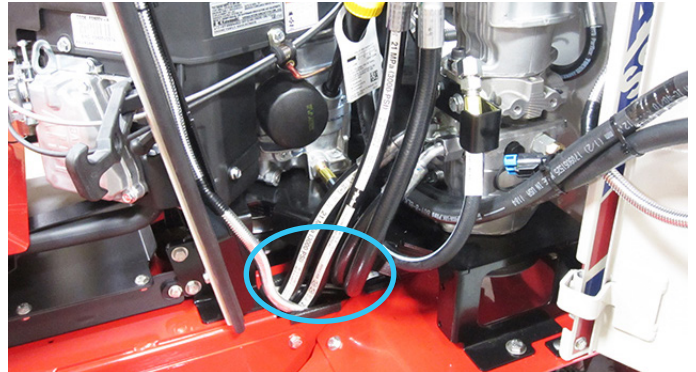

- 24. Route the hose through the grommet in the rear of the main frame and connect to the barbed fitting on the center brine nozzle assembly.

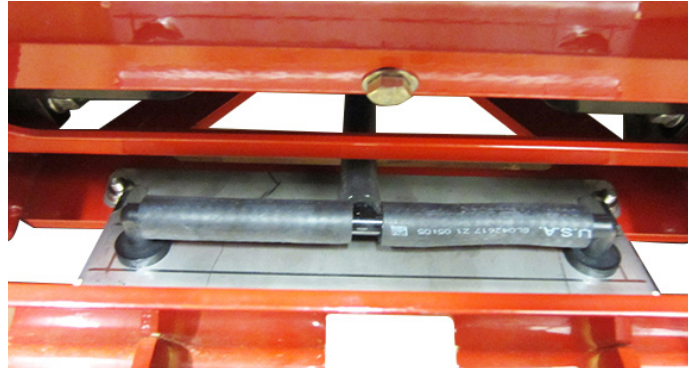

- 25. Use a 1/2" cushioned clamp (F) to secure the hose to the main frame below the fuel tank. Fasten the clamp to the frame using a 1/4 x 1" bolt, washer, and flange nut. Use two zip ties (G) to fasten the hose to the rear cross plate next to the fuel tank. Torque the clamp bolt to 72 in-lbs (8 Nm).

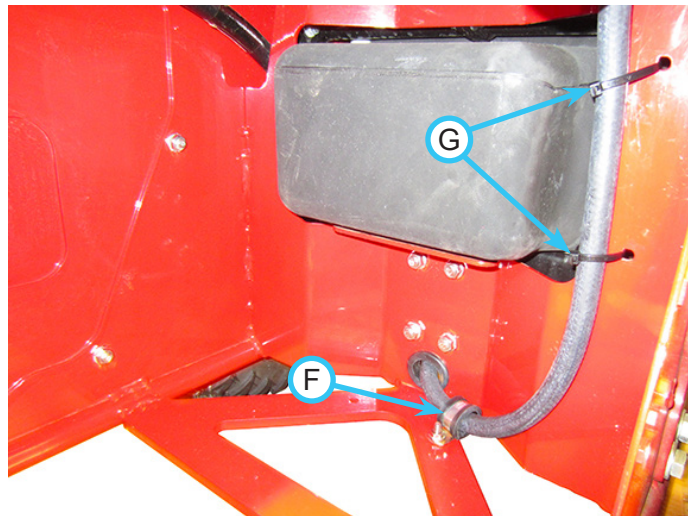

SETUP

26. Connect the hose (H) from the left and right brine nozzle assemblies to the tee on the hose fitting.

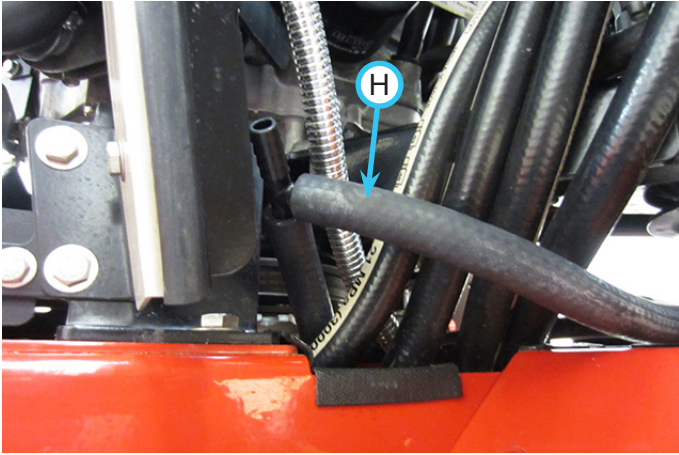

27. Unfasten the crate brackets from the crate and remove the brine tank assembly.
28. Remove the crate brackets from the tank frame. Save the hardware for reuse.
29. Install the left (I) and right (J) rear accessory mounts onto the tank frame using the hardware from the crate brackets. Do not tighten. NOTE: the power unit mounting flanges must be toward the outer edge of the frame.



30. Place the brine tank assembly onto the accessory mount/shield frame on the front of the power unit.



31. Fasten the left and right rear accessory mounts to the flanges of the accessory mount/shield frame using a 5/16 x 3/4" bolt, washer, and flange nut for each mount. Do not tighten.

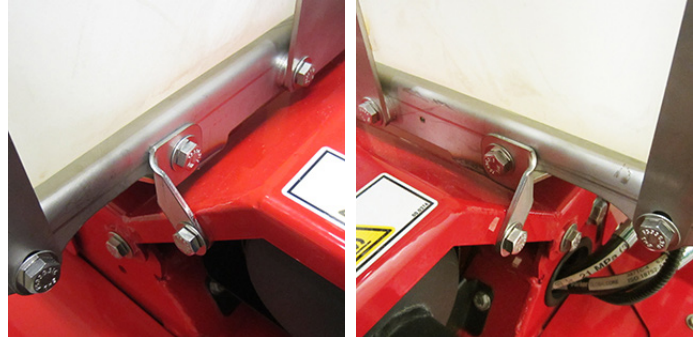

32. Install the front accessory mount bracket (K) onto the brine tank frame and the front flange of the accessory mount/shield frame using 4) 5/16 x 3/4" bolts, washers, and flange nuts. Torque the bolts to 149 in-lbs (17 Nm).

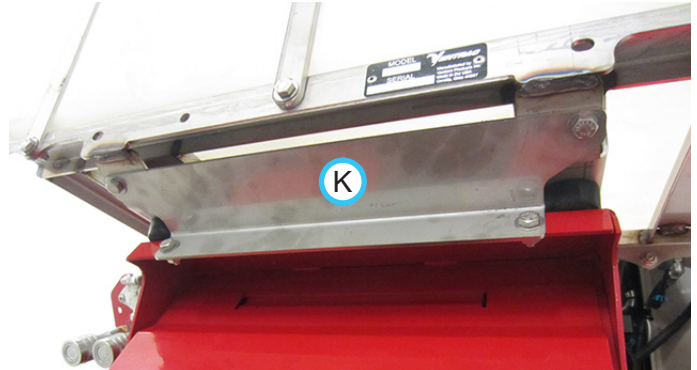

33. Torque the bolts for the left and right rear mounting brackets to 149 in-lbs (17 Nm).
34. Apply thread sealant to the fitting (L) on the spray gun hose and install into the front port on the on/off control valve.

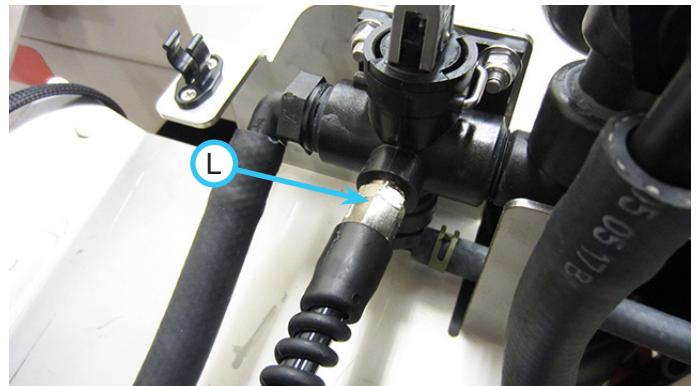

35. Insert the spray gun nozzle into the front holder and press the spray gun into the plastic clip next to the on/off control valve.

SETUP

36. Route the hose from the bottom port of the on/off control valve through the clamp (M) on the left side of the main tower frame and down past the engine into the left frame area. Connect the hose to the tee fitting from the brine nozzles.



37. Rotate the clamp to hold the hose in proper alignment and torque the bolt to 72 in-lbs (8 Nm).
38. Route the connector on the pump harness through the clamp on the right side of the main tower and down past the engine into the right frame area.

39. Locate the switch location (N) in the right dash panel. Shining a light from beneath the dash will help show the area of the decal to remove.

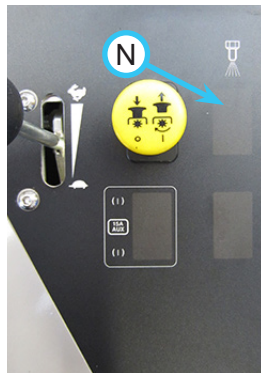

40. Using a utility knife, cut the decal to match the hole in the dash panel.
41. Install the switch (O) into the dash cutout with the light toward the front of the power unit.



42. Locate the brine system wire harness and install the switch connector onto the switch. Hold the switch in place with one hand while installing the switch connector.

43. Locate the female MP280 connector (P) with gray (A-058) and black (A-116) wires behind the fuse panel. Remove the cap and connect to the male MP280 connector on the brine system harness.

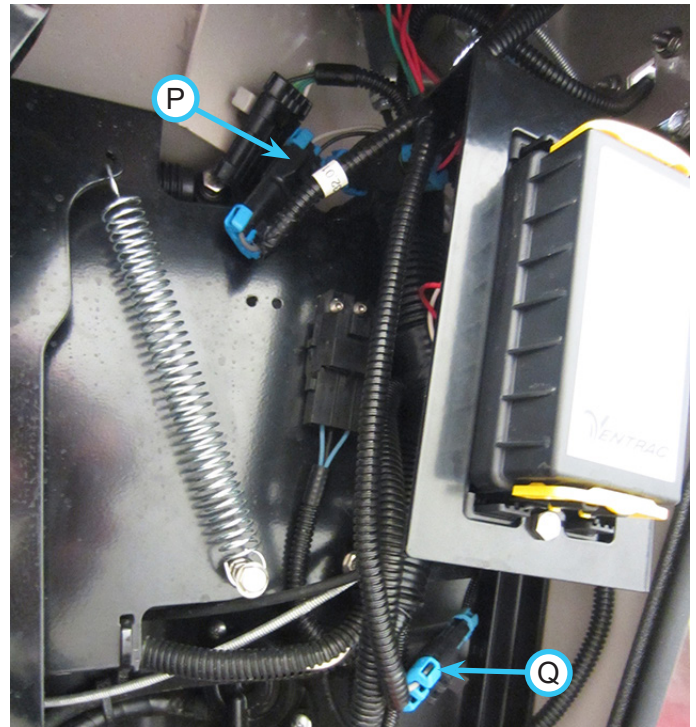

44. Connect the female MP280 connector (Q) on the brine system harness to the male MP280 connector on the pump harness.
45. Use a zip tie to fasten the brine system harness to the main harness behind the fuse panel.
46. Rotate the clamp on the tower frame to hold the wire harness in proper alignment and torque the bolt to 72 in-lbs (8 Nm).
47. Install the 15 amp fuse into position 8 in the fuse panel and reinstall the fuse panel cover.
48. Reinstall the left frame side cover. Torque bolts to 149 in-lbs (17 Nm).
49. Reinstall the left fender center platform. Torque bolts to 149 in-lbs (17 Nm).
50. Reinstall the pump belt drive cover. Torque the bolts to 72 in-lbs (8 Nm).
51. Place the operator cushion back on the power unit.
52. Reset the battery disconnect switch.

Installation is complete.

OPERATIONAL CONTROLS

Operational Control Locations

Use the following images to help identify the locations of operational controls. The letter next to each control can be referenced to the list that follows these images.

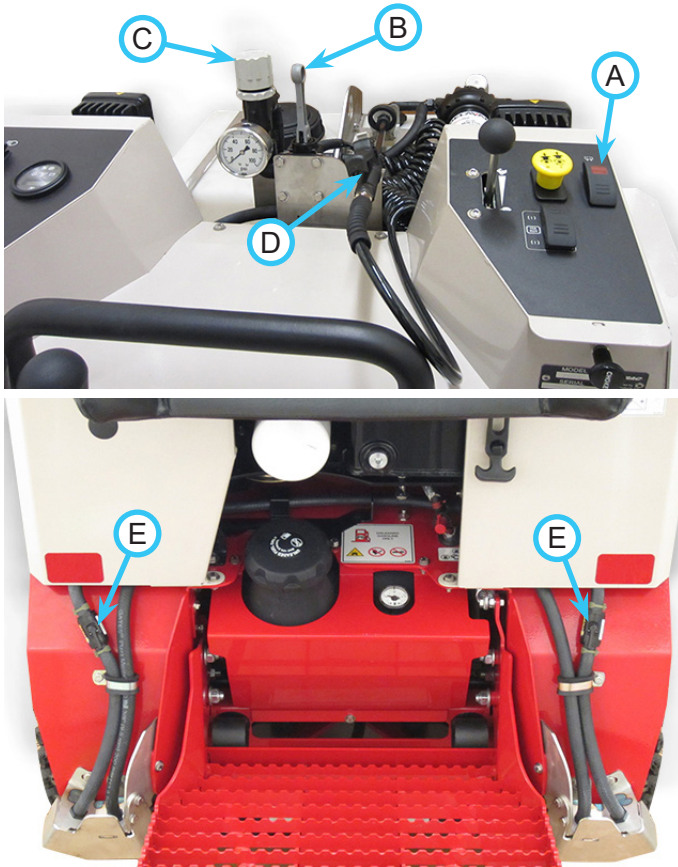

- A. Pump Switch
- B. On/Off Control Valve
- C. Pressure Regulating Valve
- D. Hand Held Spray Gun
- E. Outer Spray Nozzle Valves

Pump Switch (A)

Pressing the top portion of the pump switch turns on the brine system pump. The pump switch light will turn on when electrical power is being supplied to the pump. Pressing the bottom portion of the switch turns the pump off.

On/Off Control Valve (B)

The on/off control valve turns on or shuts off flow to the spray nozzles. Rotate the handle forward or backward 90 degrees to turn on the flow of brine solution to the spray nozzles. Rotate the handle to the vertical position to shut off the flow of brine solution to the spray nozzles. Brine solution flows through the control valve to the pressure regulating valve and the spray gun with the handle in all positions.

Pressure Regulating Valve (C)

The pressure regulating valve controls the pressure of the brine system. Turning the handle clockwise increases system pressure. Turning the handle counterclockwise decreases system pressure. The valve is equipped with a pressure relief bypass that returns excess brine solution to the main tank.

Hand Held Spray Gun (D)

The spray gun is equipped with a 15 foot (4 meter) coiled hose and is used to treat small or hard to reach areas. Squeeze the handle to activate the spray gun. The handle can be locked in the On position by pushing the handle lock forward.

The spray pattern can be adjusted by rotating the nozzle tip on the spray gun until the desired spray pattern is achieved.

Outer Spray Nozzle Valves (E)

The outer spray nozzle valves control the flow of brine solution to the outer nozzle on each side of the power unit.

GENERAL OPERATION

Daily Inspection

⚠ WARNING

Always set the parking brake, shut off power unit engine, remove the ignition key, and ensure all moving parts have come to a complete stop before inspecting components, or attempting any repair or adjustment.

1. Park machine on a level surface, with the engine shut off and all fluids cold.
2. Perform a visual inspection of both the power unit and the brine system. Look for loose or missing hardware, damaged components, or signs of wear.
3. Inspect hoses and fittings to ensure tight, leak free connections.
4. Check nozzles for even spray pattern.
5. Refer to the power unit operator's manual. Check the power unit's engine oil, hydraulic oil, tire pressure, and fuel level. Add fluid or service as required.
6. Test the power unit's operator safety interlock system*.

Operating Procedure

Before operation, perform daily inspection, set the pressure regulating valve to the desired pressure, and turn the outer spray nozzles on or off to set the desired overall width of the spray pattern.

Move the machine into position and turn on the brine system pump. Move the on/off valve handle to the On position to start the flow of brine solution. Drive forward following the sidewalk or other treatment area. When the end of the treatment area is reached, stop the machine and move the on/off valve handle to the Off position.

When treating an area that is wider than the spray pattern, spray in a back and forth pattern until the entire area has been treated.

Use the spray gun to treat steps and hard to reach areas. Move the on/off valve handle to the Off position. Park the power unit close to the treatment area and engage the parking brake. Use the spray gun to treat the area, then return the spray gun to its storage position.

Spraying Width

The spraying width can be adjusted to match the width of the sidewalk being treated by turning the left and right outer spray nozzles on or off.

Outer spray nozzle valve positions	Spraying width
Both valves On	4 feet (122 cm)
One valve On , one valve Off	3-1/2 feet (106.7 cm)
Both valves Off	3 feet (91.4 cm)

Pressure Regulation

Adjusting the pressure varies the flow rate through the nozzles. Rotate the handle on the pressure regulating valve to increase or decrease the pressure to the desired setting. Tighten the plastic lock nut against the handle to lock the handle in the desired position. Note that pressures will change when the on/off valve is turned on and off as well as when the outer spray nozzles are turned on and off.

Brine System Pressure Settings

The following chart gives the recommended brine system pressure settings based on spraying width and power unit speed. Adjustments may be necessary to achieve your desired application results.

Recommended Brine System Pressure Settings			
Spray Width	at 4 mph (6.4 km/h)	at 6 mph (9.7 km/h)	at 8 mph (12.9 km/h)
3 feet (91.4 cm)	15 PSI	25 PSI	30 PSI
3-1/2 feet (106.7 cm)	15 PSI	25 PSI	Maximum Pressure
4 feet (122 cm)	15 PSI	Maximum Pressure	Maximum Pressure

SERVICE

⚠ WARNING

Always set the parking brake, shut off power unit engine, remove the ignition key, and ensure all moving parts have come to a complete stop before inspecting components or attempting any repair or adjustment.



Attention

If any component requires replacement, use only original Ventrac replacement parts.

Cleaning and General Maintenance

For best results, and to maintain the finish of the power unit and brine system, clean or wash the brine system and power unit to remove dirt, brine and salt deposits, and snow or ice accumulations.



Attention

To maintain the finish of the power unit and attachment, thoroughly wash the equipment after each use to remove any corrosive agents (e.g., salt). Failure to clean the equipment may result in corrosion of (including but not limited to) steel, aluminum, and electrical components. Equipment that will experience repeated exposure to corrosive agents should be pretreated with a corrosion preventative.

Cleaning the Filter Element

1. Turn off electrical power to the brine system pump.
2. Place a rag underneath the filter (A) to catch any spills or drips.

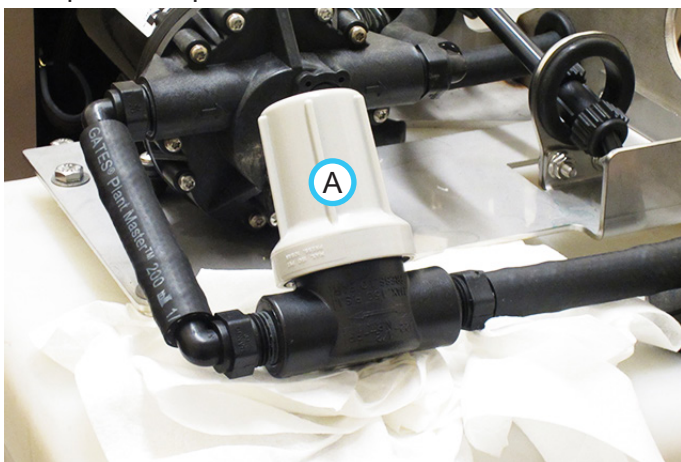

3. Loosen the filter cap slightly, then wait for several seconds to allow brine solution to drain back into the tank.

4. Remove the filter cap from the filter.
5. Carefully remove the filter screen from the filter head and rinse under clean running water to remove debris.
6. Insert the filter screen into the filter head.
7. Ensure the gasket is properly seated in the filter cap and reinstall the cap onto the filter head.

Cleaning the Nozzles

1. Park the power unit on a level surface.
2. Shut off the power unit's engine, engage the parking brake, and remove the key from the ignition.
3. Remove the nozzle tip (A) and filter screen from the nozzle base by unthreading the nut (B) from the base.

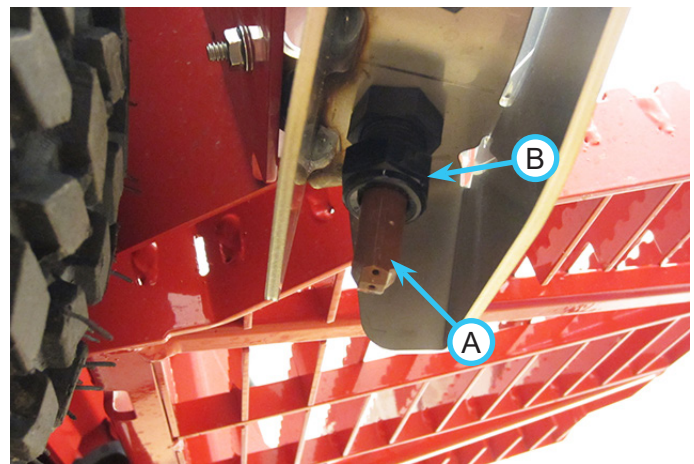

4. Rinse the filter screen under clean running water to remove debris.
5. Reinstall the filter screen and nozzle tip onto the nozzle base. Do not overtighten.

SERVICE

Draining and Flushing the Brine System

1. Park the power unit on a level surface.
2. Shut off the power unit's engine and engage the parking brake.
3. Move the on/off valve handle to the Off position.
4. If the brine tank is empty, skip to step 14.
5. If the brine tank is full, open the left door of the power unit.
6. Place a small basin next to the tee fitting at the base of the engine frame to catch any liquid that drains from the hose.

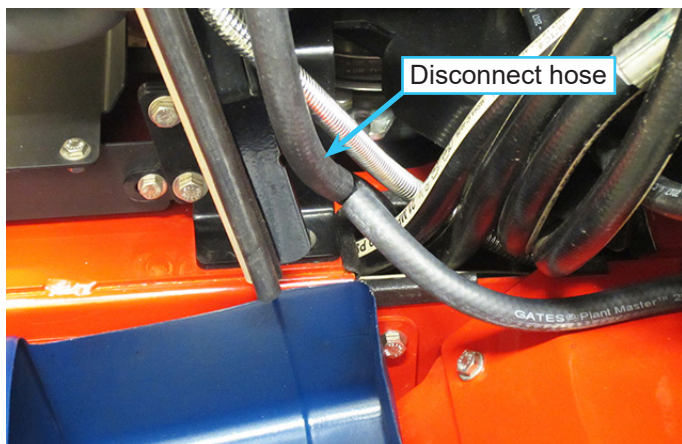

7. Disconnect the hose coming down from the brine system and let it drain into the basin.
8. Place a container next to the power unit to catch the brine solution.
9. Pull the hose out of the power unit and hold the end over the container.



10. Turn the ignition key to the On position and turn on the pump switch.
11. Move the on/off valve handle to the On position to discharge the brine solution into the container.
12. When the brine tank is empty, turn off the pump.
13. Reinstall the hose onto the tee fitting.
14. Refill the brine tank with clean water.
15. Turn on the pump switch and turn both outer

- nozzle valves to the On position. Check to ensure all the nozzles are being flushed.
16. Remove the spray gun from the power unit, squeeze the handle, and engage the handle lock.
17. Allow the system to flush until the brine tank is empty, then refill with clean water and flush a second time.
18. After flushing is complete, it is recommended to treat the system with RV antifreeze if the power unit will be stored outside in cold temperatures.
19. Add a gallon of RV antifreeze to the brine tank.
20. Turn on the pump switch and on/off valve and allow to run until the antifreeze starts to discharge from the nozzles.
21. Turn the on/off valve to the Off position to shut off flow to the nozzles.
22. Remove the spray gun from the power unit and squeeze the handle until antifreeze discharges from the spray gun.
23. Turn off the pump switch. The brine system is now treated for cold weather storage.

Storage Between Snow Events

Store inside to prevent freezing when temperatures are extremely low. Drain, flush, and treat the brine system if the machine will be stored outside during extremely low temperatures.

SERVICE

Removal of Brine Tank

If the brine system will not be used for an extended period of time, the brine tank and controls can be removed from the power unit, while leaving the hoses, brackets, and nozzles in place.

1. Wash the power unit and brine system thoroughly to remove brine deposits.
2. Park the power unit on a level surface.
3. Shut off the power unit's engine and engage the parking brake.
4. Drain and flush the brine system.
5. Open the left door of the power unit.
6. Place a small basin next to the tee fitting at the base of the engine frame to catch any liquid that drains from the hose.
7. Disconnect the hose coming down from the brine system and let it drain into the basin.
8. Pull the hose out of the front of the power unit tower frame.
9. Remove the cap (A) from the fitting mounted on the valve control bracket and install the end of the hose (B) onto the fitting for storage.

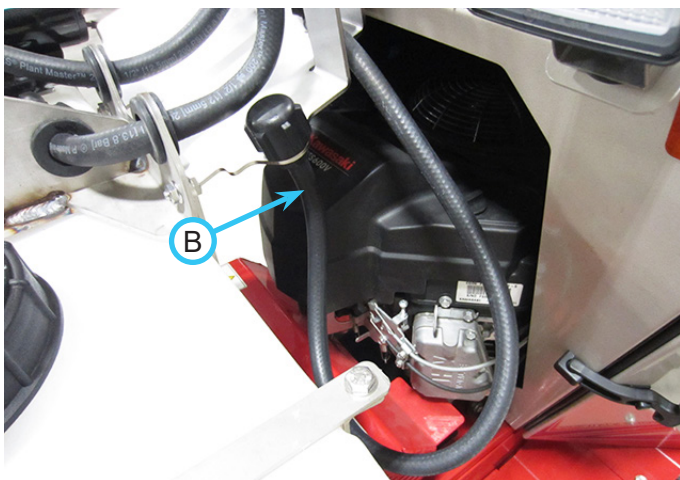

10. Install the cap onto the lower tee fitting where the hose was removed.

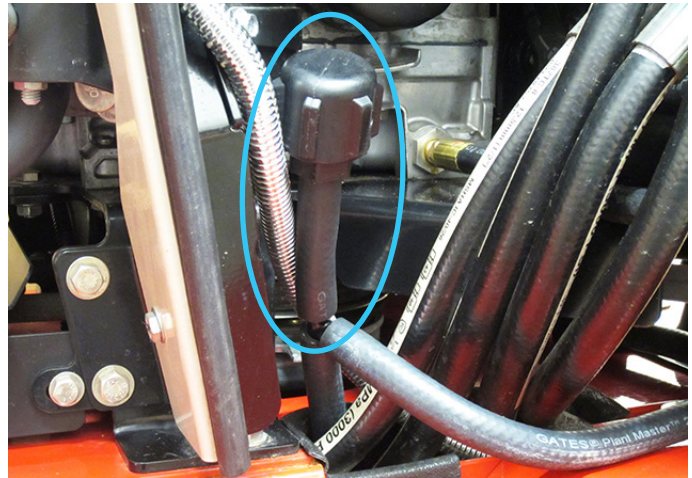

11. Disconnect the pump wire connector from the power unit harness and remove from the clamp on the power unit.
12. Cap or tape the connector on the power unit harness to prevent dust and deposits from contaminating the terminals and prevent the loss of the connector seal.
13. Remove the hardware that fastens the front mounting bracket and the left and right rear mounting brackets to the accessory mount shield frame.
14. Use a hoist to lift the brine tank assembly off the power unit. Use care to ensure the brine controls and spray gun do not catch on or bump into other parts on the power unit.
15. After removing the tank assembly from the power unit, the plug in the bottom of the tank can be removed to drain the tank completely before placing in storage.

SPECIFICATIONS

Dimensions

Overall Height	28 inches (71.1 cm)
Overall Length	24 inches (61 cm)
Overall Width	28-1/2 inches (72.4 cm)
Weight (Dry)	75 pounds (34 kg)
Brine Capacity	20 gallons (75.7 L)
Spray Width	36 - 48 inches (91.4 - 122 cm)

Features

- All stainless steel construction
- Rear mounted spray nozzles with adjustable spray width
- Hand held spray gun with 15' (4 meter) coiled hose
- Pressure regulating relief valve
- In-line main filter and filter screens at each nozzle

PARTS

ILLUSTRATED DRAWING Tank Base Frame Mount

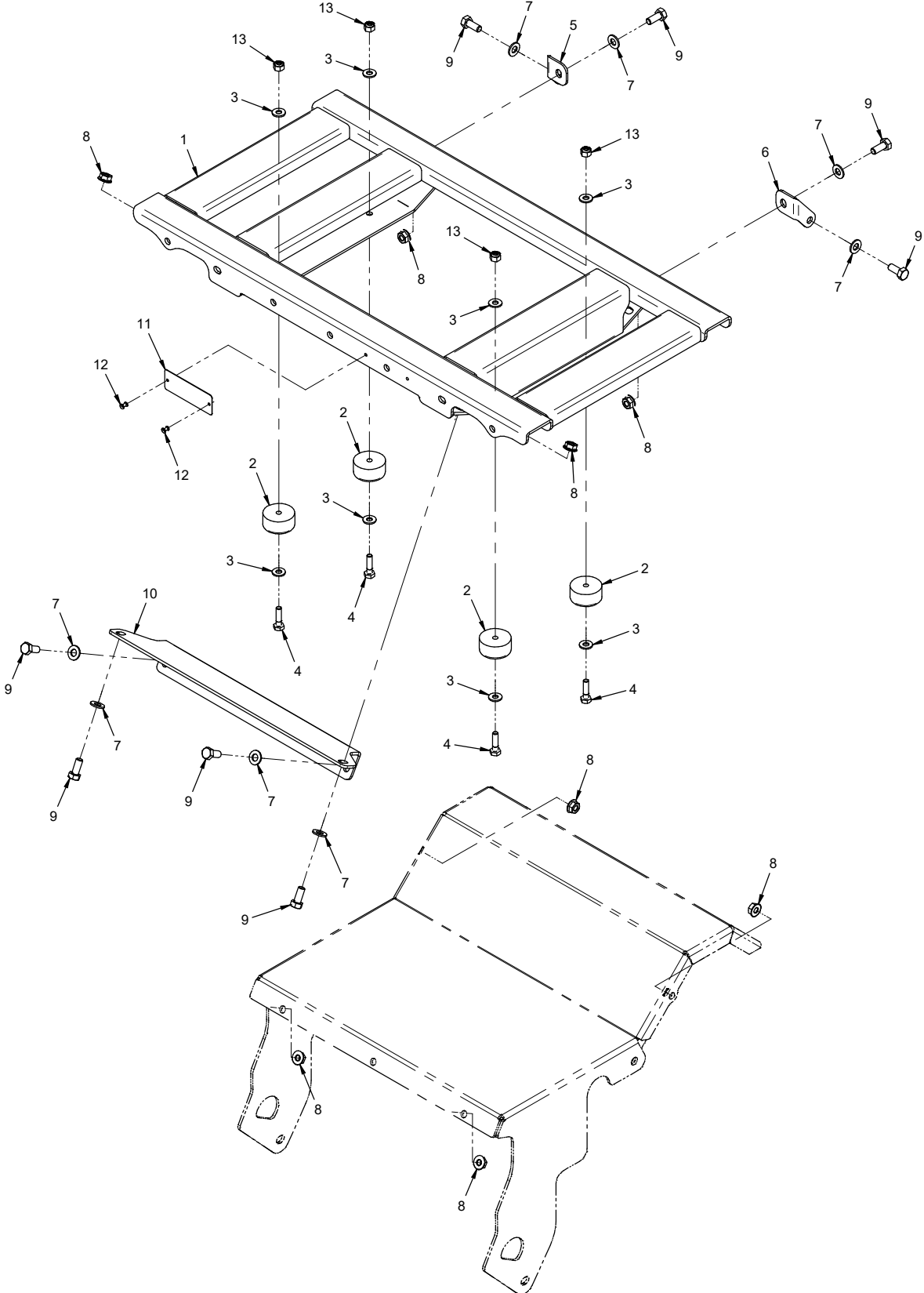

PARTS

Tank Base Frame Mount

REF.	PART NO.	DESCRIPTION	QTY.
1	NB-6100	.Frame, Brine Tank Base	1
2	05.0095	.Bumper, Rubber Cylindrical	4
3	95.04-3	.Washer, Flat 1/4 SAE SS	8
4	90.0408-3	.Bolt, 1/4-20 USS x 1 SS	4
5	NB-1123	.Bracket, Accessory Mount Right.	1
6	NB-1124	.Bracket, Accessory Mount Left.	1
7	95.05-3	.Washer, Flat 5/16 SAE SS	8
8	99.SF05-3	.Nut, SRF 5/16-18 USS Stainless	8
9	90.0506-3	.Bolt, 5/16-18 USS x 3/4 SS	8
10	NB-1165	.Bracket, Accessory Mount Front.	1
11	N/A	.Plate, Ventrac Serial Number	1
12	04.0029	.Rivet, Pop 1/8" X 1/4"	2
13	99.A04N-3	.Locknut, Nylon 1/4-20 USS SS	4

PARTS

ILLUSTRATED DRAWING Brine Tank & Mounting Straps

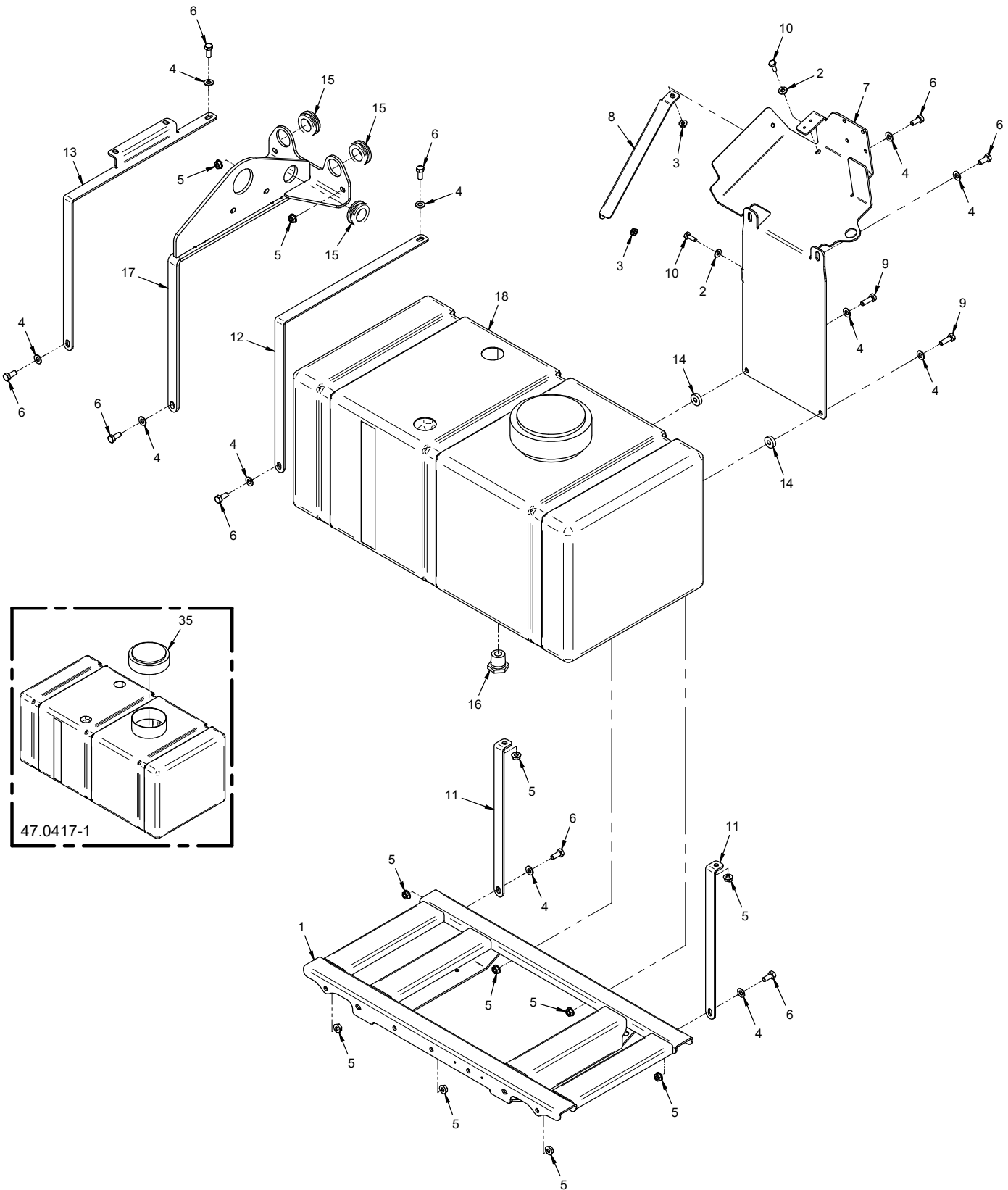

PARTS

Brine Tank & Mounting Straps

REF.	PART NO.	DESCRIPTION	QTY.
1	NB-6100	.Frame, Brine Tank Base	1
2	95.04-3	.Washer, Flat 1/4 SAE SS	2
3	99.SF04-3	.Nut, SRF 1/4-20 USS Stainless	2
4	95.05-3	.Washer, Flat 5/16 SAE SS	11
5	99.SF05-3	.Nut, SRF 5/16-18 USS Stainless	11
6	90.0506-3	.Bolt, 5/16-18 USS x 3/4 SS	9
7	NB-1128	.Bracket, Valve Controls	1
8	NB-1151	.Brace, Control Bracket	1
9	90.0508-3	.Bolt, 5/16-18 USS X 1 SS	2
10	90.0406-3	.Bolt, 1/4-20 USS x 3/4 SS	2
11	NB-1140	.Strap, Tank Mount Rear	2
12	NB-1125	.Strap, Tank Mount Left	1
13	NB-1107	.Strap, Tank Mount Right	1
14	NB-1126	.Washer, 11/32 x 7/8 x 1/4T SS	2
15	05.0177	.Grommet, 1" ID, 1-3/4" OD, 5/8" Thk	3
16	29.0114	.Fitting, Plug 3/4" MPT	1
17	NB-6106	.Strap, Center Lift Bracket	1
18	47.0417-1	.Tank, Plastic 20 Gal W/Port Holes	1
35	47.0443	.Lid, 5" W/ Spring Vent.	1

PARTS

ILLUSTRATED DRAWING Pump & Pump Mount, Spray Gun & Mount, Pump Switch

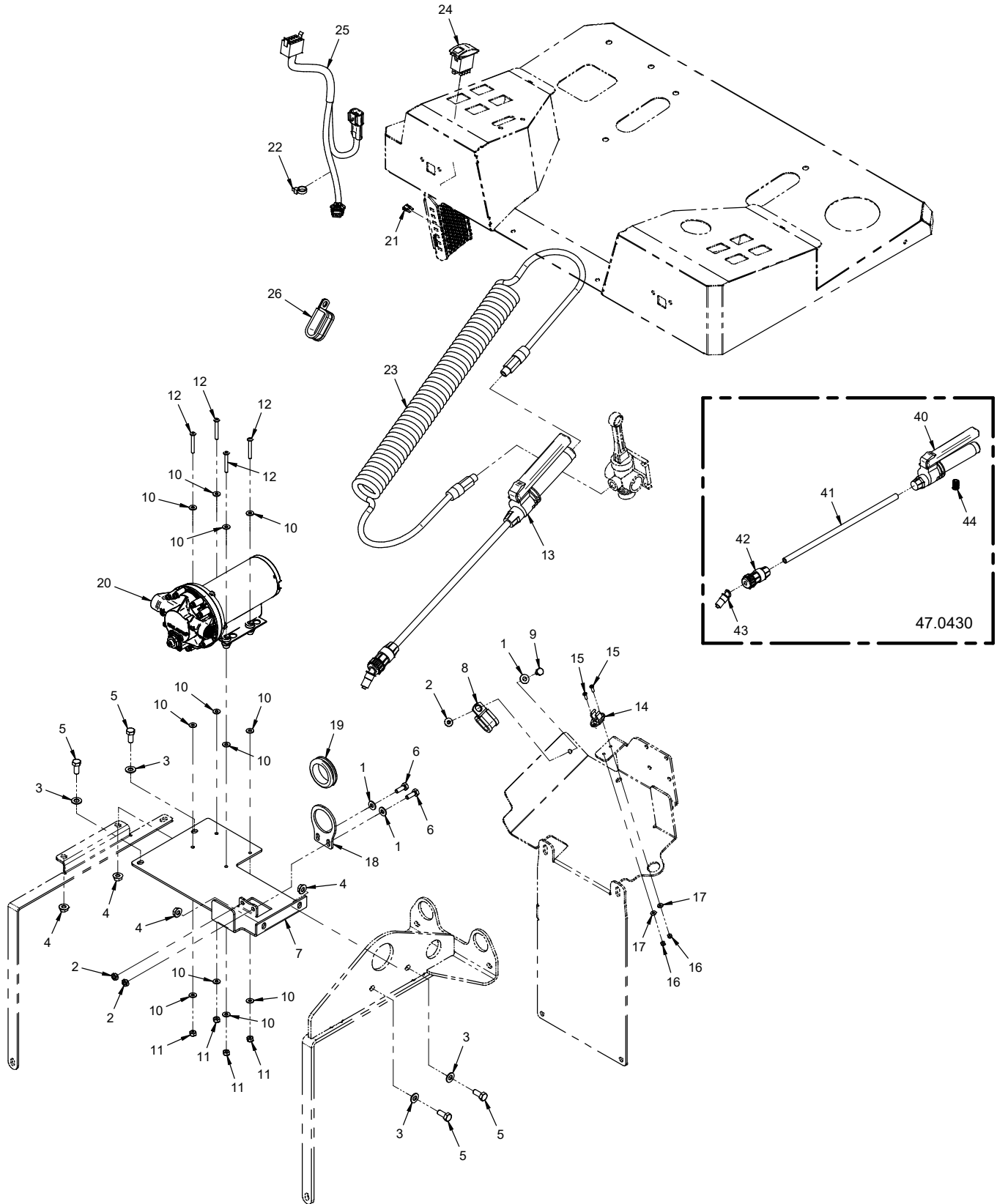

PARTS

Pump & Pump Mount, Spray Gun & Mount, Pump Switch

REF.	PART NO.	DESCRIPTION	QTY.
1	95.04-3	.Washer, Flat 1/4 SAE SS	3
2	99.SF04-3	.Nut, SRF 1/4-20 USS Stainless	3
3	95.05-3	.Washer, Flat 5/16 SAE SS	4
4	99.SF05-3	.Nut, SRF 5/16-18 USS Stainless	4
5	90.0506-3	.Bolt, 5/16-18 USS x 3/4 SS	4
6	90.0406-3	.Bolt, 1/4-20 USS x 3/4 SS	2
7	NB-1129	.Plate, Pump Mount	1
8	11.0046	.Clamp, Cushioned 1/2" 2-Tube	1
9	90.0404-3	.Bolt, 1/4-20 USS x 1/2 SS	1
10	99.B0126	.Washer, Flat #10 SS	12
11	99.A1032N	.Locknut, Nylon 10-32 Stainless	4
12	99.K0154	.Machine Screw, #10-32 X 1-1/2 SS	4
13	47.0430	.Spray Gun, 15" Ext. #12 Nozzle	1
14	47.0437	.Clip, Tool Holder 7/16 - 9/16" Dia.	1
15	99.K0153	.Machine Screw, #6-32 x 1/2 SS	2
16	99.E0118	.Locknut, Nylon #6-32 SS	2
17	99.B0127	.Washer, Flat #6 SS	2
18	NB-1135	.Mount, Sprayer Front	1
19	05.0036	.Grommet, 1 1/2ID,2 1/8OD,9/16T	1
20	37.0066	.Pump, 12V Bypass	1
21	30.0334	.Fuse, 15 Amp Mini Blue	1
22	30.0037	.Tyton Tie, #50 .18 x 8 Black	1
23	27.0006	.Hose Asm, 1/4" ID Coiled Black	1
24	31.0053	.Switch, Rocker On/Off	1
25	32.0189	.Harness, Wire NT Brine System	1
26	11.0071	.Clamp, Cushioned 3/4" 2-Tube	1
40	47.0430-1	.Handle, Spray Gun	1
41	47.0430-2	.Extension, Spray Gun	1
42	47.0430-3	.Adapter, Spray Gun Straight	1
43	47.0430-4	.Tip Assembly, 45 Deg Adjustable	1
44	47.0430-5	.Kit, Spray Gun Repair	1

PARTS

ILLUSTRATED DRAWING Brine Control Valves, Intake & Return Hose Circuit

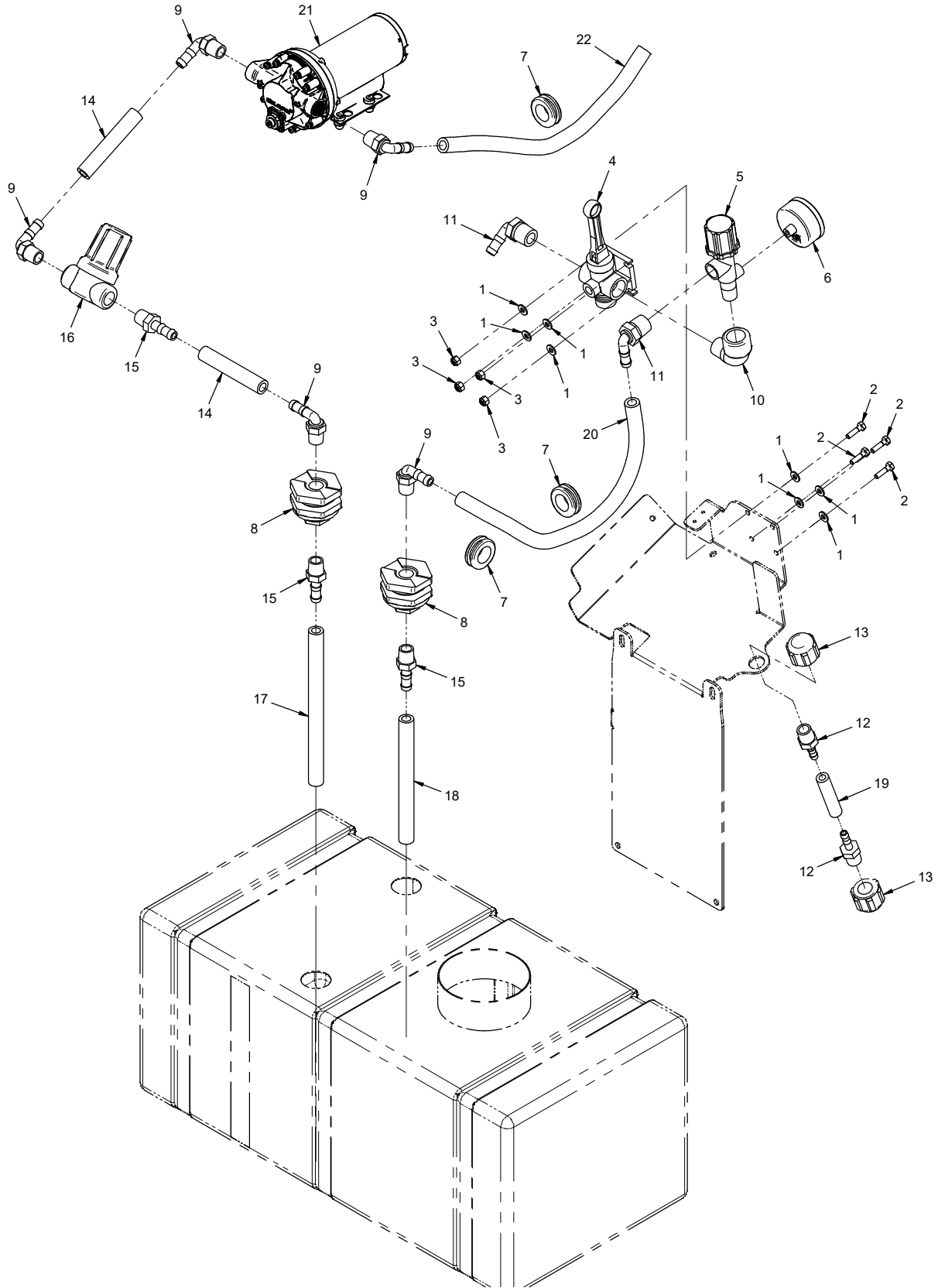

PARTS

Brine Control Valves, Intake & Return Hose Circuit

REF.	PART NO.	DESCRIPTION	QTY.
1	95.04-3	Washer, Flat 1/4 SAE SS	8
2	90.0408-3	Bolt, 1/4-20 USS x 1 SS	4
3	99.A04N-3	Locknut, Nylon 1/4-20 USS SS	4
4	23.0179	Valve, On/Off Control w/ Bypass	1
5	23.0180	Valve, Pressure Regulating Relief	1
6	35.0157	Gauge, Pressure 100 PSI	1
7	05.0177	Grommet, 1" ID, 1-3/4" OD, 5/8" Thk	3
8	29.0105	Fitting, Tank 1/2" FPT	2
9	29.0107	Fitting, 90 Elbow 1/2 MPT x 1/2 Barb	5
10	29.0111	Fitting, Street Elbow 3/4"	1
11	29.0106	Fitting, 90 Elbow 3/4 MPT x 1/2 Barb	2
12	29.0110	Fitting, St 1/2 MPT x 3/8 Barb	2
13	29.0112	Fitting, Cap 1/2" FPT	2
14	27.0005-4.5IN	Hose, EPDM Black 1/2" ID x 4-1/2"	2
15	29.0109	Fitting, St 1/2 MPT x 1/2 Barb	3
16	47.0429	Strainer, 1/2" MPT 50 Mesh	1
17	27.0005-10IN	Hose, EPDM Black 1/2" ID x 10"	1
18	27.0005-8IN	Hose, EPDM Black 1/2" ID x 8"	1
19	27.0007-3IN	Hose, EPDM Black 3/8" ID x 3"	1
20	27.0005-17IN	Hose, EPDM Black 1/2" ID x 17"	1
21	37.0066	Pump, 12V Bypass	1
22	27.0005-14.25IN	Hose, EPDM Black 1/2" ID x 14-1/4"	1

PARTS

ILLUSTRATED DRAWING

Rear Supply Hose, Center Nozzle Hose, & Center Nozzles

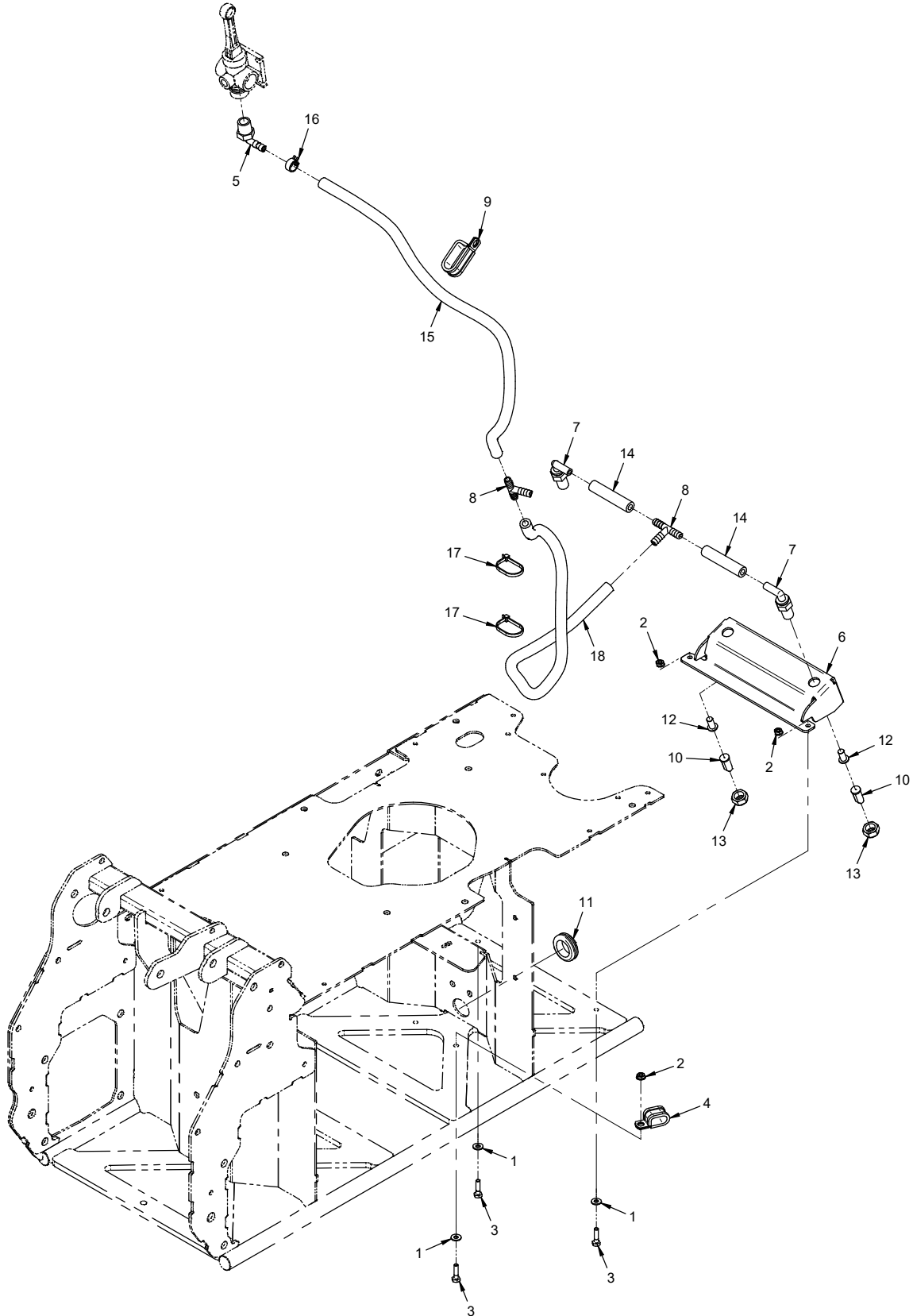

PARTS

Rear Supply Hose, Center Nozzle Hose, & Center Nozzles

REF.	PART NO.	DESCRIPTION	QTY.
1	95.04-3	Washer, Flat 1/4 SAE SS	3
2	99.SF04-3	Nut, SRF 1/4-20 USS Stainless	3
3	90.0408-3	Bolt, 1/4-20 USS x 1 SS	3
4	11.0046	Clamp, Cushioned 1/2" 2-Tube	1
5	29.0108	Fitting, 90 Elbow 1/2 MPT x 3/8 Barb	1
6	NB-1200	Mount, Brine Nozzle Center	1
7	47.0432	Nozzle Body, 90 Elbow	2
8	29.0115	Fitting, Tee Barb 3/8 x 3/8 x 3/8	2
9	11.0071	Clamp, Cushioned 3/4" 2-Tube	1
10	47.0439	Nozzle, 3 Hole 05 Orifice	2
11	05.0060	Grommet, 1-1/8 ID, 1-3/4 OD	1
12	47.0434	Nozzle Strainer, Check Valve	2
13	47.0435	Cap, Nozzle	2
14	27.0007-3.25IN	Hose, EPDM Black 3/8" ID x 3-1/4"	2
15	27.0007-30IN	Hose, EPDM Black 3/8" x 30"	1
16	11.0086	Clamp, Hose Band 5/8" OD Hose	1
17	30.0037	Tyton Tie, #50 .18 x 8 Black	2
18	27.0007-32IN	Hose, EPDM Black 3/8" x 32"	1

PARTS

ILLUSTRATED DRAWING Left & Right Outer Nozzles

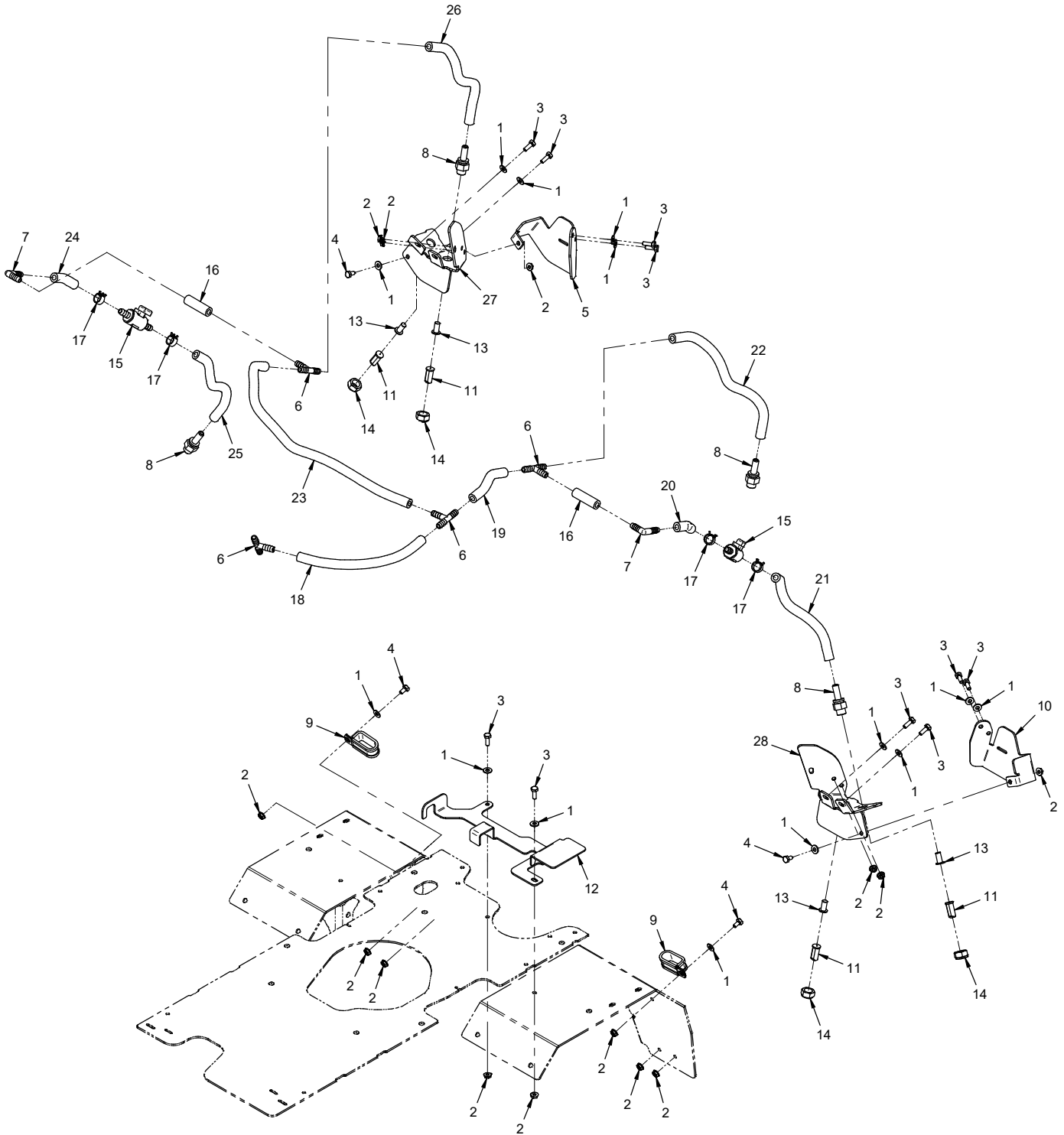

PARTS

Left & Right Outer Nozzles

REF.	PART NO.	DESCRIPTION	QTY.
1	95.04-3	Washer, Flat 1/4 SAE SS	14
2	99.SF04-3	Nut, SRF 1/4-20 USS Stainless	14
3	90.0406-3	Bolt, 1/4-20 USS x 3/4 SS	10
4	90.0404-3	Bolt, 1/4-20 USS x 1/2 SS	4
5	NB-1275	Shield, Brine Nozzle Right	1
6	29.0115	Fitting, Tee Barb 3/8 x 3/8 x 3/8	4
7	29.0116	Fitting, 90 Elbow 3/8 Barb	2
8	47.0431	Nozzle Body, Straight	4
9	11.0071	Clamp, Cushioned 3/4" 2-Tube	2
10	NB-1280	Shield, Brine Nozzle Left	1
11	47.0439	Nozzle, 3 Hole 05 Orifice	4
12	NB-1305	Bracket, Hose Retainer	1
13	47.0434	Nozzle Strainer, Check Valve	4
14	47.0435	Cap, Nozzle	4
15	23.0181	Valve, Micro Ball 3/8" Barb	2
16	27.0007-2.25IN	Hose, EPDM Black 3/8" ID x 2-1/4"	2
17	11.0086	Clamp, Hose Band 5/8" OD Hose	4
18	27.0007-9.5IN	Hose, EPDM Black 3/8" x 9-1/2"	1
19	27.0007-6IN	Hose, EPDM Black 3/8" ID x 6"	1
20	27.0007-2.5IN	Hose, EPDM Black 3/8" ID x 2-1/2"	1
21	27.0007-9.5IN	Hose, EPDM Black 3/8" ID x 9-1/2"	1
22	27.0007-13IN	Hose, EPDM Black 3/8" ID x 13"	1
23	27.0007-23IN	Hose, EPDM Black 3/8" ID x 23"	1
24	27.0007-2.5IN	Hose, EPDM Black 3/8" ID x 2-1/2"	1
25	27.0007-9.5IN	Hose, EPDM Black 3/8" ID x 9-1/2"	1
26	27.0007-13IN	Hose, EPDM Black 3/8" ID x 13"	1
27	NB-6205	Mount, Brine Nozzle Right	1
28	NB-6200	Mount, Brine Nozzle Left	1

WARRANTY



LIMITED WARRANTY - VENTRAC TURF EQUIPMENT

Venture Products, Inc., (henceforth referred to as V.P.I.) warrants on the terms and conditions herein, that it will repair, replace, or adjust any part manufactured by Venture Products Inc., and found by Venture Products, Inc., to be defective in material and/or workmanship during the applicable warranty term.

All Ventrac commercial equipment purchased and registered on or after January 1, 2019 will carry a 2-year commercial warranty. The warranty period begins on the date of original customer purchase:

Ventrac Commercial Equipment	Warranty Term
2100 SSV & Attachments	2-year
3000 Series Tractors & Attachments	2-year
4000 Series Tractors & Attachments	2-year

All Ventrac add-on kits and accessories such as: 3-point hitch, 12V front & rear power outlets, foot pedal, dual wheel kit, etc., will be covered under the above warranty periods provided they are installed by an Authorized Ventrac Dealer. This warranty may be transferred and will carry the remainder of the warranty starting from the original purchase/registration date with the dealership and/or V.P.I.

The engine warranty is covered by its respective engine manufacturer. Please refer to the engine manufacturer's warranty statement that is included in the owner's manual.

For warranty consideration on Ventrac commercial equipment, including any defective part, must be returned to an Authorized Ventrac Dealer within the warranty period. The warranty shall extend to the cost to repair or replace (as determined by V.P.I.) the defective part. The expense of pickup and delivery of equipment, service call drive time or any transportation expense incurred for warranty repair is the sole responsibility of the owner and is not covered under warranty by Ventrac and/or V.P.I. Ventrac and V.P.I.'s responsibility in respect to claims is limited to making the required repairs or replacements, and no claim of breach of warranty shall be cause for cancellation or rescission of the contract of sale of any Ventrac equipment. Proof of purchase may be required by the dealer to substantiate any warranty claim. Only warranty work performed and submitted by an Authorized Ventrac Dealer may be eligible for warranty credit.

This warranty extends only to Ventrac commercial equipment operated under normal conditions and properly serviced and maintained. The warranty expressly does NOT cover: (a) any defects, damage or deterioration due to normal use, wear and tear, or exposure; (b) normal maintenance services, such as cleaning, lubrication, oil change; (c) replacement of service items, such as oil, lubricants, spark plugs, belts, rubber hoses, bearings or other items subject to normal service replacement; (d) damage or defects arising out of, or relating to abuse, misuse, neglect, alteration, negligence or accident; (e) repair or replacement arising from operation of, or use of the equipment which is not in accordance with operating instructions as specified in the operator's manual or other operational instructions provided by V.P.I.; (f) repair or replacement arising as a result of any operation from Ventrac equipment that has been altered or modified so as to, in the determination of V.P.I., adversely affect the operation, performance or durability of the equipment or that has altered, modified or affected the equipment so as to change the intended use of the product; (g) repair or replacement necessitated by the use of parts, accessories or supplies, including gasoline, oil or lubricants, incompatible with the equipment or other than as recommended in the operator's manual or other operational instructions provided by V.P.I.; (h) repairs or replacements resulting from parts or accessories which have adversely affected the operation, performance or durability of the equipment; or (i) damage or defects due to or arising out of repair of Ventrac equipment by person or persons other than an authorized Ventrac service dealer or the installation of parts other than genuine Ventrac parts or Ventrac recommended parts.

WARRANTY



LIMITED WARRANTY - VENTRAC TURF EQUIPMENT

The sole liability of V.P.I. with respect to this warranty shall be the repair and replacement as set forth herein. V.P.I. shall have no liability for any other cost, loss, or damage. In particular V.P.I. shall have no liability or responsibility for: (i) expenses relating to gasoline, oil, lubricants; (ii) loss, cost or expense relating to transportation or delivery of turf equipment from the location of owner or location where used by owner to or from any Authorized Ventrac Dealer; (iii) travel time, overtime, after hours' time or other extraordinary repair charges or charge relating to repairs or replacements outside of normal business hours at the place of business of an Authorized Ventrac Dealer; (iv) rental of like or similar replacement equipment during the period of any warranty repair or replacement work; (v) any telephone or telegram charges; (vi) loss or damage to person or property other than that covered by the terms of this warranty; (vii) any claims for lost revenue, lost profit or additional cost or expense incurred as a result of a claim of breach of warranty; or (viii) attorney's fees.

The remedies of buyer set forth herein are exclusive and are in lieu of all other remedies. The liability of V.P.I., whether in contract, tort, under any warranty, or otherwise, shall not extend beyond its obligation as set forth herein. V.P.I. shall not be liable for cost of removal or installation nor shall V.P.I. be responsible for any direct, indirect, special or consequential damages of any nature. In no event shall V.P.I. be liable for any sum in excess of the price received for the goods for which liability is claimed.

There are no representations or warranties which have been authorized to the buyer of the Ventrac commercial equipment other than set forth in this warranty. Any and all statements or representations made by any seller of this equipment, including those set forth in any sales literature or made orally by any sales representative, are superseded by the terms of this warranty. Any affirmation of fact or promise made by V.P.I. or any of its representatives to the buyer which relates to the goods that are the subject to this warranty shall not be regarded as part of the basis of the bargain and shall not be deemed to create any express warranty that such goods shall conform to the affirmation or promise.

No employee, distributor, or representative is authorized to change the foregoing warranties in any way or grant any other warranty on behalf of V.P.I.

Some states do not allow limitations on how long an implied warranty lasts or allow the exclusion on limitation of incidental or consequential damages, so the above limitation or exclusion may not apply to you.

This warranty gives you specific legal rights, and you may also have other rights which vary from state to state.

This warranty applies to all Ventrac commercial equipment sold by Venture Products Inc.