



*Operator's Manual
& Parts Drawings*

SA250

Drop Spreader





500 Venture Drive
Orrville Oh 44667
www.ventrac.com

View all manuals



Visit ventrac.com/manuals for the latest version of this operator's manual.

A downloadable parts manual is also available.

To the Owner Contact Information and Product Identification

If you need to contact an authorized Ventrac dealer for information on servicing your product, always provide the product model and serial numbers.

Please fill in the following information for future reference. See the picture(s) below to find the location of the identification numbers. Record them in the spaces provided.

Date of Purchase: _____

Dealer: _____

Dealer Address: _____

Dealer Phone Number: _____

Dealer Fax Number: _____

<p>Model # (A): _____</p> <p>Serial # (B): _____</p> <p>Affix Part/Serial Number label here.</p>
--



Venture Products Inc. reserves the right to make changes in design or specifications without obligation to make like changes on previously manufactured products.

TABLE OF CONTENTS

INTRODUCTION	PAGE 5
Product Description.....	5
Why Do I Need an Operator’s Manual?	5
Using Your Manual	6
Manual Glossary	6
SAFETY	PAGE 7
Safety Decals	7
General Safety Procedures.....	8
Training Required.....	8
Personal Protective Equipment Requirements	8
Operation Safety	8
Preventing Accidents.....	9
Keep Riders Off.....	9
Operating On Slopes.....	10
Roadway Safety	10
Truck Or Trailer Transport	10
Maintenance.....	11
Fuel Safety	11
Hydraulic Safety	12
SA250 Safety Procedures.....	13
SETUP	PAGE 14
SA250 Install 4200/4500 Kit.....	14
SA250 Install 3400 Kit.....	17
SA250 Install 3100/3200 Kit.....	20
SA250 Install Universal 2” Receiver Kit	24
SA250 Install Universal 3 Point Kit.....	27
OPERATIONAL CONTROLS	PAGE 30
Transmitter (Remote Control)	30
Hopper Cover Strap	30
GENERAL OPERATION	PAGE 31
Daily Inspection.....	31
Attaching (Receiver Hitch)	31
Detaching (Receiver Hitch)	31
Attaching (3-Point Hitch)	31
Detaching (3-Point Hitch).....	31
Spreader Loading.....	32
Spreader Operation.....	33
Application Rates	33
Gate Adjustment.....	34

TABLE OF CONTENTS

SERVICE	PAGE 35
Cleaning and General Maintenance.....	35
Service Access Points.....	35
Lubrication Locations.....	36
Motor Oil Level.....	36
Changing The Motor Oil.....	36
Drive Chain.....	37
Drive Chain Tension Inspection.....	37
Drive Chain Tension Adjustment.....	37
Controller Bypass.....	38
Synchronizing Remote Transmitter To Controller Unit.....	38
Replacing Remote Control Batteries.....	39
Storage.....	39
Maintenance Schedule.....	40
Maintenance Checklist.....	40
SPECIFICATIONS	PAGE 41
Dimensions.....	41
Technical Information.....	41
Features.....	41
PARTS	PAGE 42
Main Frame.....	42
Rear & Side Bumpers.....	44
Hopper Panels.....	46
Spreader Hanger, Hopper Screen, & Top Cover.....	48
Gate Panel & Guides.....	50
Gate Control Rocker.....	52
Motor & Rotor.....	54
Front Bin Seal & Rear Roller Seal.....	56
End Panel Stiffeners, Covers, & Clamps.....	58
Controller & Lights.....	60
70.8149 Hopper Extension Kit.....	62
70.8150 High Speed Sprocket Kit.....	64
70.8186 Slow Speed Sprocket Kit.....	66
70.8140 SA250 Install For 4200/4500.....	68
70.8141 SA250 Install For 3400.....	70
70.8151 SA250 Install For 3100/3200.....	72
70.8142 SA250 Install Universal 2" Receiver.....	74
70.8143 SA250 Install 3 Point Hitch.....	76
WARRANTY	PAGE 78

INTRODUCTION



Venture Products Inc. is pleased to provide you with your new Ventrac SA250 drop spreader! We hope that Ventrac equipment will provide you with a ONE Tractor Solution.

Listed below are just some of the items that can provide you *versatility* as you use your SA250. Please visit our web site, or contact your authorized Ventrac dealer for a complete list of items available for your new SA250 drop spreader.

Accessories	Item Description	Part Number
	Hopper Extension Kit	70.8149*
	High Speed Sprocket Kit	70.8150
	Slow Speed Sprocket Kit	70.8186
	4200/4500 Install Kit for SA250^	70.8140
	3400 Install Kit for SA250^	70.8141
	3100/3200 Install Kit for SA250^	70.8151
	Universal 2" Receiver Install Kit for SA250^	70.8142
	Universal 3-Point Hitch Install Kit for SA250^	70.8143

*Hopper extension should not be used on a Ventrac 3000 series power unit.

^An install kit is required for mounting the SA250 drop spreader to a power unit. Ensure you have the correct installation kit for your application.

Product Description

The Ventrac SA250 drop spreader is designed to spread an array of deicing materials with precision flow control. With a narrow frame and a 40" (102 cm) drop pattern, the drop spreader is ideal for spreading material on sidewalks and other narrow walkways.

The drop spreader is equipped with a unique compression roller system to evenly distribute material. Easy gate adjustment allows for fine tuning flow rates based on the type of material being spread and the desired quantity being applied. A wireless remote control regulates five motor speeds for quick flow adjustments from the operator's seat.

Stainless steel construction prevents premature failure due to rust and corrosion. An innovative agitation system prevents material bridging and eliminates the need for a traditional, noisy vibration motor.

Mounting options are available for specific Ventrac power units. Universal mounting options are available for a 2" receiver hitch or a category one 3-point hitch.

Why Do I Need an Operator's Manual?

This manual has been created to help you gain the important knowledge of what is needed to safely operate, maintain, and service your machine. It is divided into sections for convenient reference of the appropriate section.

You must read and understand the operator's manual for each piece of Ventrac equipment you own. Reading the operator's manual will help you become familiar with each specific piece of equipment. Understanding the operator's manual will help you, as well as others, avoid personal injury and/or damage to the equipment. Keep this manual with the machine at all times. The manual should remain with the machine even if it is sold. If this manual becomes damaged or unreadable, it should be replaced immediately. Contact your local Ventrac dealer for a replacement.

When using a Ventrac attachment, be sure to read and follow the safety and operating instructions of both the power unit and the attachment being used to ensure the safest operation possible.

The information in this manual provides the operator with the safest procedures to operate the machine while getting the maximum use out of the unit. Failure to follow the safety precautions listed in this manual may result in personal injury and/or damage to the equipment.

INTRODUCTION

Using Your Manual

Throughout this manual, you will encounter special messages and symbols that identify potential safety concerns to help you as well as others avoid personal injury or damage to the equipment.

SYMBOL DEFINITIONS



ATTENTION

This symbol identifies potential health and safety hazards. It marks safety precautions. Your safety and the safety of others is involved.

There are three signal words that describe the level of safety concern: Danger, Warning, and Caution. Safety should always be the #1 priority when working on or operating equipment. Accidents are more likely to occur when proper operating procedures are not followed or inexperienced operators are involved.

Note: Right-Hand and Left-Hand orientations may be referred to at different places throughout this manual. Right-Hand and Left-Hand is determined as if sitting on the power unit seat facing forward.

SIGNAL WORD DEFINITIONS

⚠ DANGER

Indicates an imminently hazardous situation which, if not avoided, will result in death or serious injury. This signal word is limited to the most extreme cases.

⚠ WARNING

Indicates a potentially hazardous situation which, if not avoided, could result in death or serious injury.

⚠ CAUTION

Indicates a potentially hazardous situation which, if not avoided, may result in minor or moderate injury and/or property damage. It may also be used to alert against unsafe practices.

Manual Glossary

Power Unit A Ventrac tractor or other Ventrac engine powered device that may be operated by itself or with an attachment or accessory.

Attachment A piece of Ventrac equipment that requires a Power Unit for operation.

Accessory A device that attaches to a Power Unit or Attachment to extend its capabilities.

Machine Describes any "Attachment" or "Accessory" that is used in conjunction with a power unit.

SAFETY

Safety Decals

The following safety decals must be maintained on your SA250 drop spreader.

Keep all safety decals legible. Remove all grease, dirt, and debris from safety decals and instructional labels. If any decals are faded, illegible, or missing, contact your dealer promptly for replacements.

When new components are installed, be sure that current safety decals are affixed to the replacement components.

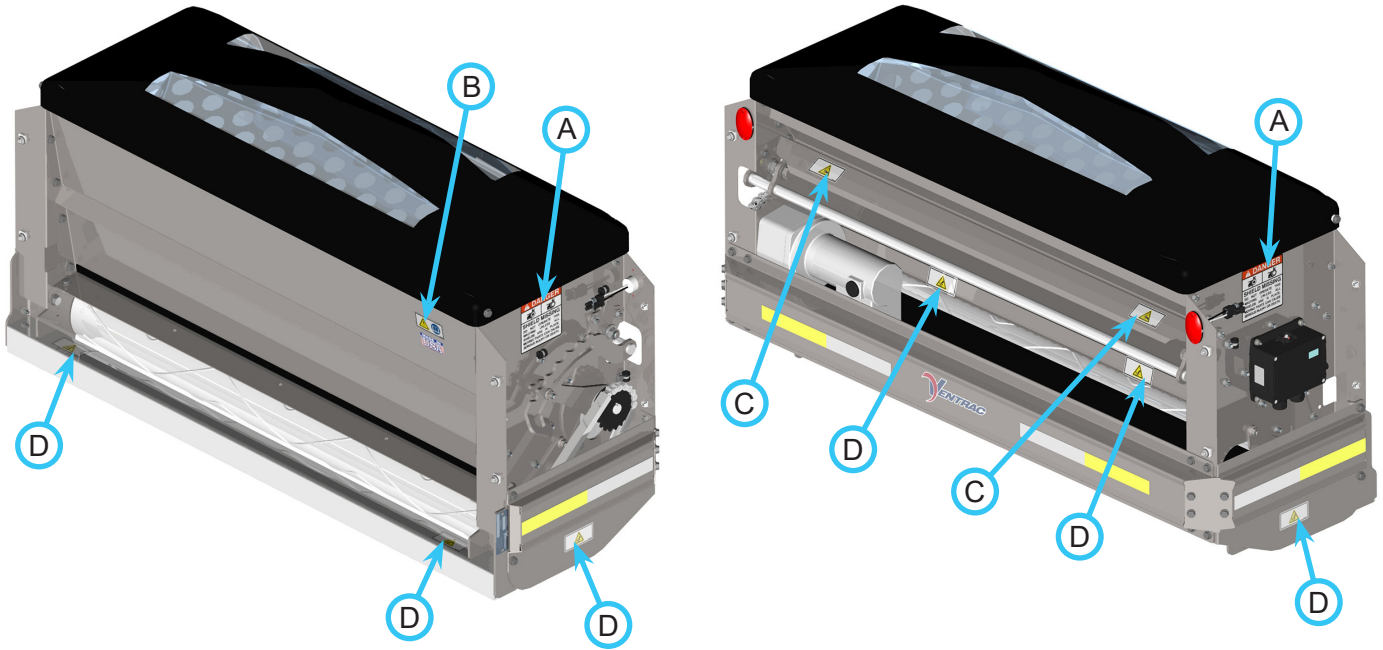

Decal	Description	Part Number	Quantity
A	Danger, Shield Missing	00.0062	2
B	Warning, Read Owner's Manual	00.0363	1
C	Warning, Pinch Point	00.0364	2
D	Warning, Moving Parts	00.0365	6

SAFETY



General Safety Procedures for Ventrac Power Units, Attachments, & Accessories



Training Required

- The owner of this machine is solely responsible for properly training the operators.
- The owner/operator is solely responsible for the operation of this machine and prevention of accidents or injuries occurring to him/herself, other people, or property.
- Do not allow operation or service by children or untrained personnel. Local regulations may restrict the age of the operator.
- Before operating this machine, read the operator's manual and understand its contents.
- If the operator of the machine cannot understand this manual, then it is the responsibility of this machine's owner to fully explain the material within this manual to the operator.
- Learn and understand the use of all controls.
- Know how to stop the power unit and all attachments quickly in the event of an emergency.



Personal Protective Equipment Requirements

It is the responsibility of the owner to be sure that the operators use the proper personal protective equipment while operating the machine. Required personal protective equipment includes, but is not limited to, the following list.



- Wear a certified ear protection device to prevent loss of hearing.
- Prevent eye injury by wearing safety glasses while operating the machine.
- Closed toe shoes must be worn at all times.
- Long pants must be worn at all times.
- When operating in dusty conditions, it is recommended that a dust mask be worn.

Operation Safety

- Inspect machine before operation. Repair or replace any damaged, worn, or missing parts. Be sure guards and shields are in proper working condition and are secured in place. Make all necessary adjustments before operating machine.
- Some pictures in this manual may show shields or covers opened or removed in order to clearly illustrate any instructions. Under no circumstance should the machine be operated without these devices in place.
- Alterations or modifications to this machine can reduce safety and could cause damage to the machine. Do not alter safety devices or operate with shields or covers removed.
- Before each use, verify that all controls function properly and inspect all safety devices. Do not operate if controls or safety devices are not in proper working condition.
- Check parking brake function before operating. Repair or adjust parking brake if necessary.
- Observe and follow all safety decals.
- All controls are to be operated from the operator's station only.
- Always wear a seat belt if the machine has a roll cage/bar installed and in upright position.
- Ensure the attachment or accessory is locked or fastened securely to the power unit before operating.
- Ensure that all bystanders are clear of the power unit and attachment before operating. Stop machine if someone enters your work area.
- Always be alert to what is happening around you, but do not lose focus on the task you are performing. Always look in the direction the machine is moving.
- Look behind and down before backing up to be sure of a clear path.
- If you hit an object, stop and inspect the machine. Make all necessary repairs before operating machine again.
- Stop operation immediately at any sign of equipment failure. An unusual noise can be a warning of equipment failure or a sign that maintenance is required. Make all necessary repairs before operating machine again.

SAFETY



General Safety Procedures for Ventrac Power Units, Attachments, & Accessories



Operation Safety (continued)

- If equipped with a high/low range feature, never shift between high and low range while on a slope. Always move the machine to level ground and engage the parking brake before shifting range.
- Do not leave machine unattended while it is running.
- Always park the machine on level ground.
- Always shut off engine when connecting attachment drive belt to the power unit.
- Never leave the operator's station without lowering the attachment to the ground, setting the parking brake, shutting off the engine, and removing the ignition key. Make sure all moving parts have come to a complete stop before dismounting.
- Never leave equipment unattended without lowering the attachment to the ground, setting the parking brake, shutting off the engine, and removing the ignition key.
- Only operate in well-lit conditions.
- Do not operate when there is a risk of lightning.
- Never direct the discharge of any attachment in the direction of people, buildings, animals, vehicles, or other objects of value.
- Never discharge material against a wall or obstruction. Material may ricochet back towards the operator.
- Use extra caution when approaching blind corners, shrubs, trees, or other objects that may obscure vision.
- Do not run the engine in a building without adequate ventilation.
- Do not touch the engine or the muffler while the engine is running or immediately after stopping the engine. These areas may be hot enough to cause a burn.
- Do not change the engine governor settings or over-speed the engine. Operating engine at excessive speed may increase the hazard of personal injury.
- To reduce the hazard of fire, keep the battery compartment, engine, and muffler areas free of grass, leaves, excessive grease, and other flammable materials.

Preventing Accidents



- Clear working area of objects that might be hit or thrown from machine.
- Keep people and pets out of working area.
- Know the work area well before operation. Do not operate where traction or stability is questionable.
- Reduce speed when you are operating over rough ground.
- Equipment can cause serious injury and/or death when improperly used. Before operating, know and understand the operation and safety of the power unit and the attachment being used.
- Do not operate machine if you are not in good physical and mental health, if you will be distracted by personal devices, or are under the influence of any substance which might impair decision, dexterity, or judgment.
- Children are attracted to machine activity. Be aware of children and do not allow them in the working area. Turn off the machine if a child enters the work area.



Keep Riders Off

- Only allow the operator on the power unit. Keep riders off.
- Never allow riders on any attachment or accessory.

SAFETY



General Safety Procedures for Ventrac Power Units, Attachments, & Accessories



Operating On Slopes

- Slopes can cause loss-of-control and tip-over accidents, which can result in severe injury or death. Be familiar with the emergency parking brake, along with the power unit controls and their functions.
- If power unit is equipped with a fold down roll bar, it must be locked in the upright position when operating on any slope.
- Use low range (if equipped) when operating on slopes greater than 15 degrees.
- Do not stop or start suddenly when operating on slopes.
- Never shift between high and low range while on a slope. Always move the power unit to level ground and engage the parking brake before shifting range or placing the power unit in neutral.
- Variables such as wet surface and loose ground will reduce the degree of safety. Do not drive where machine could lose traction or tip over.
- Keep alert for hidden hazards in the terrain.
- Stay away from drop-offs, ditches, and embankments.
- Sharp turns should be avoided when operating on slopes.
- Pulling loads on hills decreases safety. It is the responsibility of the owner/operator to determine loads that can safely be controlled on slopes.
- Transport machine with attachment lowered or close to the ground to improve stability.
- While operating on slopes, drive in an up and down direction when possible. If turning is necessary while driving across slopes, reduce speed and turn slowly in the downhill direction.
- Assure a sufficient supply of fuel for continuous operation. A minimum of one-half tank of fuel is recommended.

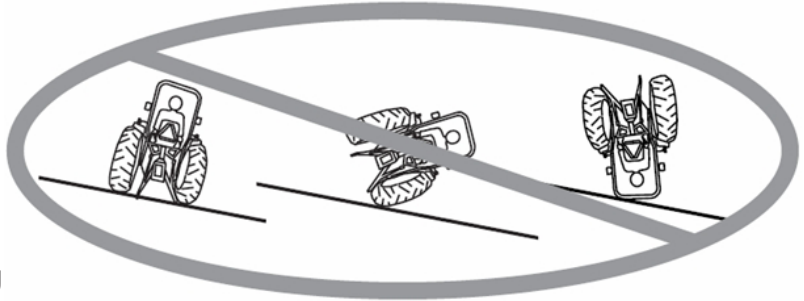

Roadway Safety

- Operate with safety lights when operating on or near roadways.
- Obey all state and local laws concerning operation on roadways.
- Slow down and be careful of traffic when operating near or crossing roadways. Stop before crossing roads or sidewalks. Use care when approaching areas or objects that may obscure vision.
- If there is doubt of safety conditions, discontinue machine operation until a time when operation can be performed safely.
- When operating near or on roadways, have a Slow Moving Vehicle Emblem clearly displayed.

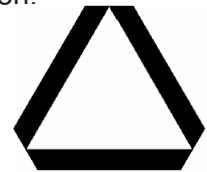

Truck Or Trailer Transport

- Use care when loading or unloading machine into a truck or trailer.
- Use full width ramps for loading machine into a truck or trailer.
- The parking brake is not sufficient to lock the machine during transport. Always secure the power unit and/or attachment to the transporting vehicle securely using straps, chains, cable, or ropes. Both front and rear straps should be directed down and outward from the machine.
- Shut off fuel supply to power unit during transport on truck or trailer.
- If equipped, turn the battery disconnect switch to the Off position to shut off electrical power.

SAFETY



General Safety Procedures for Ventrac Power Units, Attachments, & Accessories



Maintenance

- Keep all safety decals legible. Remove all grease dirt, and debris from safety decals and instructional labels.
- If any decals are faded, illegible, or missing, contact your dealer promptly for replacements.
- When new components are installed, be sure that current safety decals are affixed to the replacement components.
- If any component requires replacement, use only original Ventrac replacement parts.
- Always turn the battery disconnect to the Off position or disconnect the battery before performing any repairs. Disconnect the negative terminal first and the positive terminal last. Reconnect the positive terminal first and the negative terminal last.
- Keep all bolts, nuts, screws, and other fasteners properly tightened.
- Always lower the attachment to the ground, engage parking brake, shut off engine, and remove the ignition key. Make sure all moving parts have come to a complete stop before cleaning, inspection, adjusting or repairing.
- If the power unit, attachment, or accessory requires repairs or adjustments not instructed in the operator's manual, the power unit, attachment, or accessory must be taken to an authorized Ventrac dealer for service.
- Never perform maintenance on the power unit and/or attachment if someone is in the operator's station.
- Always use protective glasses when handling the battery.
- Check all fuel lines for tightness and wear on a regular basis. Tighten or repair them as needed.
- To reduce the hazard of fire, keep the battery compartment, engine, and muffler areas free of grass, leaves, and excessive grease.
- Do not touch the engine, the muffler, or other exhaust components while the engine is running or immediately after stopping the engine. These areas may be hot enough to cause a burn.
- Allow the engine to cool before storing and do not store near an open flame.
- Do not change the engine governor settings or over-speed the engine. Operating engine at excessive speed may increase the hazard of personal injury.
- Springs may contain stored energy. Use caution when disengaging or removing springs and/or spring loaded components.
- An obstruction or blockage in a drive system or moving/rotating parts may cause a buildup of stored energy. When the obstruction or blockage is removed, the drive system or moving/rotating parts may move suddenly. Do not attempt to remove an obstruction or blockage with your hands. Keep hands, feet, and clothing away from all power-driven parts.
- Dispose of all fluids in accordance with local laws.

Fuel Safety



- To avoid personal injury or property damage, use extreme care in handling gasoline. Gasoline is extremely flammable and the vapors are explosive.
- Do not refuel machine while smoking or at a location near flames or sparks.
- Always refuel the machine outdoors.
- Do not store machine or fuel container indoors where fumes or fuel can reach an open flame, spark, or pilot light.
- Only store fuel in an approved container. Keep out of reach of children.
- Never fill containers inside a vehicle or on a truck or trailer bed with a plastic liner. Always place containers on the ground away from your vehicle before filling.
- Remove machine from the truck or trailer and refuel it on the ground. If this is not possible, refuel the machine using a portable container, rather than from a fuel dispenser nozzle.
- Never remove fuel cap or add fuel with the engine running. Allow engine to cool before refueling.
- Never remove fuel cap while on a slope. Only remove when parked on a level surface.
- Replace all fuel tank and container caps securely.

SAFETY



General Safety Procedures for Ventrac Power Units, Attachments, & Accessories



Fuel Safety (continued)

- Do not overfill fuel tank. Only fill to bottom of fuel neck, do not fill fuel neck full. Overfilling of fuel tank could result in engine flooding, fuel leakage from the tank, and/or damage to the emissions control system.
- If fuel is spilled, do not attempt to start the engine. Move the power unit away from the fuel spill and avoid creating any source of ignition until fuel vapors have dissipated.
- If the fuel tank must be drained, it should be drained outdoors into an approved container.
- Dispose of all fluids in accordance with local laws.
- Check all fuel lines for tightness and wear on a regular basis. Tighten or repair them as needed.
- The fuel system is equipped with a shut-off valve. Shut off the fuel when transporting the machine to and from the job, when parking the machine indoors, or when servicing the fuel system.

Hydraulic Safety

- Make sure all hydraulic connections are tight and all hydraulic hoses and tubes are in good condition. Repair any leaks and replace any damaged or deteriorated hoses or tubes before starting the machine.
- Hydraulic leaks can occur under high pressure. Hydraulic leaks require special care and attention.
- Use a piece of cardboard and a magnifying glass to locate suspected hydraulic leaks.



- Keep body and hands away from pinhole leaks or nozzles that eject high pressure hydraulic fluid. Hydraulic fluid escaping under high pressure can penetrate the skin causing serious injury, leading to severe complications and/or secondary infections if left untreated. If hydraulic fluid is injected into the skin, seek immediate medical attention no matter how minor the injury appears.

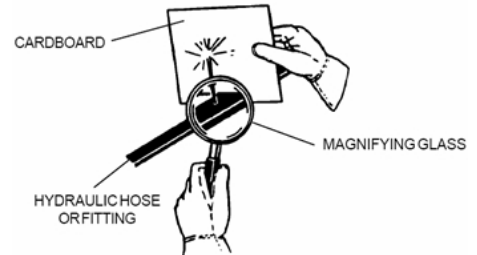

- Hydraulic system may contain stored energy. Before performing maintenance or repairs on the hydraulic system, remove attachments, engage parking brake, disengage weight transfer system (if equipped), shut off engine, and remove ignition key. To relieve pressure on the auxiliary hydraulic system, shut off the power unit engine and move the hydraulic control lever left and right before disconnecting the auxiliary hydraulic quick couplers.
- Dispose of all fluids in accordance with local laws.

SAFETY



SA250 Safety Procedures



- Spreader must be properly secured to the power unit before operating power unit and spreader.
- Never exceed the recommendations in the weight capacity charts in the operation section, which specifies the material weight that can be used with different front attachments. Exceeding the weight recommendation for your front attachment may result in loss of steering or front wheel traction.
- If using the spreader in combination with a vehicle that is not made by Ventrac, do not exceed the manufacturer's Gross Vehicle Weight Rating (GVWR). Overloading may result in unpredictable and/or unsafe vehicle handling and may cause damage to the equipment. Check your vehicle owner's manual to be sure that the installation of aftermarket equipment will not void the manufacturer's factory warranty.
- Do not operate Ventrac power unit with SA250 drop spreader on slopes greater than 10 degrees. Operation on slopes greater than 10 degrees may result in loss of steering or front wheel traction.
- Do not operate the spreader in temperatures below -20° F (-29° C) or above 50° F (10° C).
- Never attempt to remove the spreader from the power unit while there is material in the spreader hopper.
- When possible, use a crane or forklift to lift the spreader. If the spreader must be lifted manually, ask someone to assist you.
- Before attempting to clear an obstruction or empty the hopper by hand, unplug the spreader from the vehicle power supply to prevent accidental startup.
- Always make sure personnel are clear of areas of danger when using equipment.
- Never use with foreign debris in the spreader. The spreader is designed only for use with deicing materials.
- Before working with the spreader, secure all loose fitting clothing and unrestrained hair.
- Always wear safety glasses with side shields when servicing spreader.
- Read installation instructions before attaching wire harness to power source or ground.
- Do not splice any other device into the wire harness.
- The SA250 spreader is not designed for use with aftermarket vibrators/agitation systems.
- If using the spreader in combination with a vehicle that is not made by Ventrac, make sure the vehicle is capable of supplying proper amperage to the spreader. Refer to specifications section in this manual for spreader amperage.

WARNING

The spreader has a 10° max slope rating when used with a Ventrac power unit. All other uses are dependent on the rating of the vehicle being used. It is the responsibility of the owner to determine and follow the capacity and slope ratings for any vehicles that are not made by Ventrac.

SETUP

SA250 Install 4200/4500 Kit

Document Number	Kit Number / Part Number	Model	Serial Number Range
09.700198	70.8140	KT4200	All Units*
09.700198	70.8140	KN4500	All Units^

*KT4200 power units must be equipped with 12 volt rear kit # 70.4087.

^KN4500 power units must be equipped with 12 volt rear kit # 70.4105.

⚠ WARNING

Before making repairs or adjustments set the parking brake, turn off engine, and remove ignition key. Always disconnect the negative battery cable from the battery when working with electrical components. Always work in a manner that does not put safety at risk!

⚠ WARNING

Safety glasses must be worn during installation. Ear (hearing) protection must be worn when using air or power tools.

Installation Notes: Right and left hand orientation referred to in these instructions is determined as if sitting on the tractor seat, facing forwards.

Installation Time (estimated) 40 minutes
Tools Required: 3/8" wrench 3/4" wrench 3/4" socket ratchet phillips screwdriver



Attention

To prevent thread galling, lubricate the bolt threads with a lithium complex NLGI #2 grease and use hand tools to tighten stainless steel fasteners. Do not use air or electric power tools as this increases the potential of thread galling.

1. Remove the spreader from the crate and remove the crating brackets from the bottom of the spreader.
2. Open the top cover of the spreader and remove the box containing the remote control.
3. If power unit is not equipped with a cab, raise the hood and install the transmitter mount and clip assembly onto the front lip of the dash.

5. Install the remote control transmitter onto the transmitter mount and clip the lanyard to the hole in the mount.



Dash Mount



Cab Mount

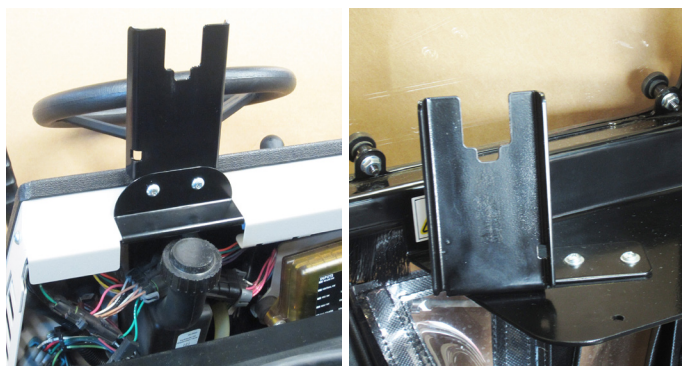

Dash Mount

Cab Mount

6. Install the spreader hitch tube onto the spreader hitch mount using 4) 1/2 x 1-1/2" bolts, 8) 1/2" flat washers, and 4) 1/2" nylon lock nuts. Ensure the holes in the hitch tube are turned to the sides to align with the holes in the hitch receiver, then torque to 75 ft-lbs (102 Nm).

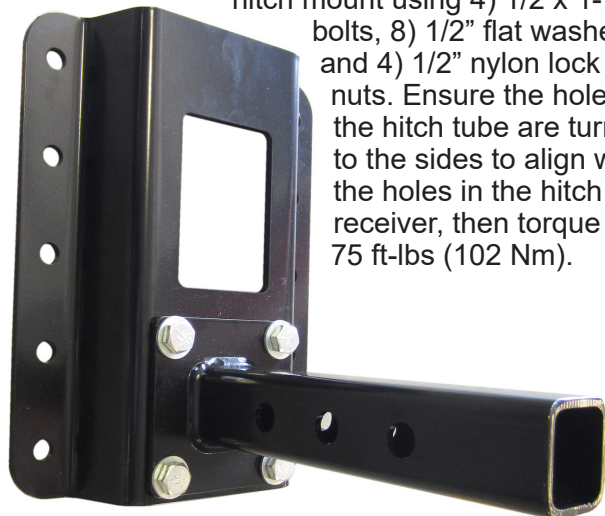

4. If power unit is equipped with a cab, install the single transmitter mount onto the dash tray of the bottom windshield mount using 2) #10-32 x 1/2" machine screws, 2) #10 washers, and 2) #10-32 flange nuts.

SETUP

- Place 1) 1/2" flat washer on each of the 4) 1/2 x 3-3/4" bolts.
- Insert a 1/2 x 3-3/4" bolt into 1) hole on both of the small hitch plates and place the hitch plates onto the spreader cross tube as shown.



- Insert a 1/2 x 3-3/4" bolt into the bottom hole on both of the small hitch plates.



- Install the spreader hitch mount onto the 4) 1/2 x 3-3/4" bolts and fasten loosely with 4) 1/2" flat washers and 4) 1/2" nylon lock nuts.

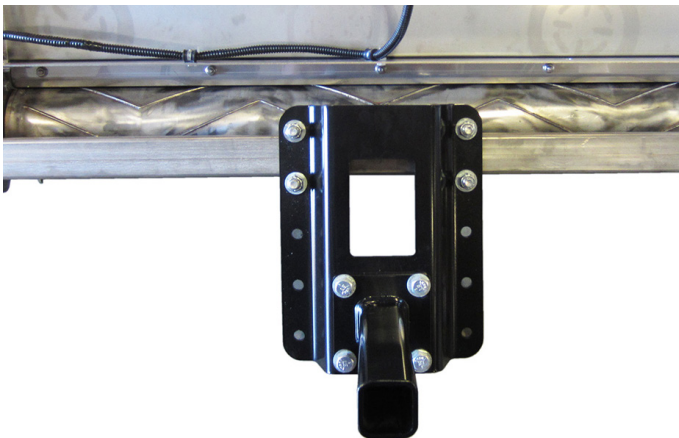

NOTE: Ventrac recommends installing the hitch

mount to the spreader using the top set of holes. This provides maximum ground clearance when driving on and off sidewalks and curbs and also when loading and unloading power unit and spreader from a truck or trailer. If clearance is not an issue, you may mount the spreader closer to the ground. This will make it easier to load ice melt products into the spreader and also gives less time for wind to affect the spread pattern of the product being applied.

- Center the spreader hitch mount on the spreader tube by measuring from the outside edge of the spreader mount plate to the inside of the main frame end plates. Torque the 1/2" lock nuts to 75 ft-lbs (102 Nm).

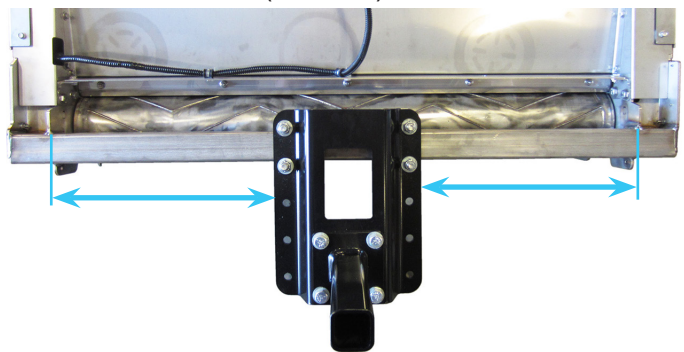

- Connect the 4 pin wire harness to the plug on the spreader harness.



- If the power unit is equipped with a standard hitch, slide the spreader hitch tube into the hitch receiver and fasten with the included clevis pin and hair pin. Use the hole in the spreader hitch tube that positions the spreader closest to the power unit without any contact between them.

SETUP

14. If the power unit is equipped with a 3 point hitch, you have two options for installation.

The recommended option is to remove the 3 point lift arms to allow the spreader to mount closer to the power unit, providing better ground clearance when loading or unloading from a truck or trailer.

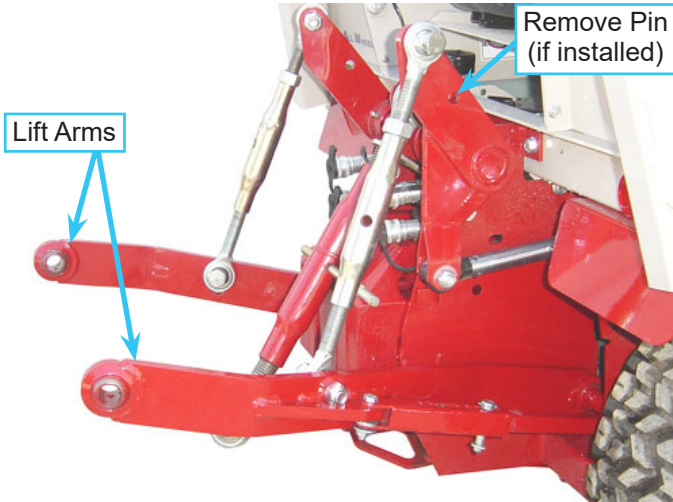

The second option is to lock the 3 point arms in the outermost position and lift the arms to the highest position. NOTE: if choosing this option, ensure there is not a locking pin installed in the 3 point lift arm rocker plate that would force the 3 point arms down if the 3 point lift lever is accidentally engaged.

Remove the center rear weight from the 3 point hitch frame. Slide the spreader hitch tube into the hitch receiver and fasten with the included clevis pin and hair pin. Use the hole in the spreader hitch tube that positions the spreader closest to the power unit without any contact between them.

15. Insert the 4 pin plug on the spreader harness into the 12 volt rear socket on the power unit. Refer to page 1 for 12 volt rear kit numbers.

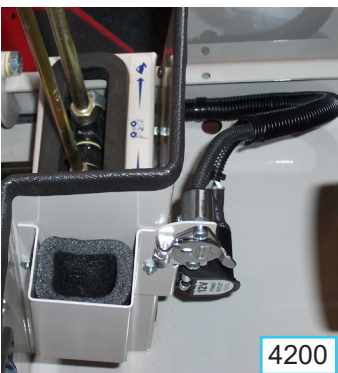

⚠ CAUTION

Power must be supplied to the SA250 spreader through a 20 amp fuse. Power supplied through a circuit breaker may result in damage to the spreader electronics. Replace any existing circuit breaker with a 20 amp fuse.

16. If installing on a KT4200 power unit, remove the 25 amp ATC fuse from the in-line fuse holder and replace with the 20 amp ATC fuse.

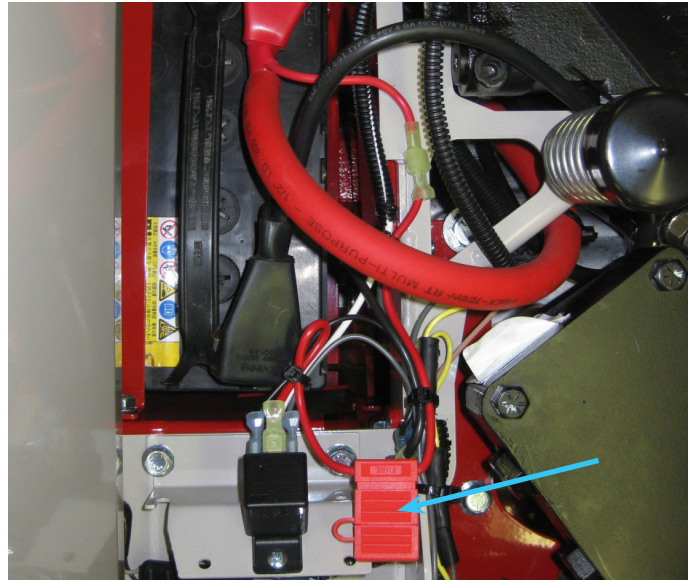

17. Coil up the slack in the spreader harness and fasten to the spreader mount plate using the included Velcro cable ties.

Installation is complete.

SETUP

SA250 Install 3400 Kit

Document Number	Kit Number / Part Number	Model	Serial Number Range
09.700199	70.8141	LH3400	All Units*

*LH power units must be equipped with 12 volt rear kit # 70.3050.

⚠ WARNING

Before making repairs or adjustments set the parking brake, turn off engine, and remove ignition key.

Always disconnect the negative battery cable from the battery when working with electrical components. Always work in a manner that does not put safety at risk!

⚠ WARNING

Safety glasses must be worn during installation. Ear (hearing) protection must be worn when using air or power tools.

Installation Notes: Right and left hand orientation referred to in these instructions is determined as if sitting on the tractor seat, facing forwards.

Installation Time (estimated) 30 minutes

Tools Required: 3/8" wrench 3/4" wrench 3/4" socket ratchet



Attention

To prevent thread galling, lubricate the bolt threads with a lithium complex NLGI #2 grease and use hand tools to tighten stainless steel fasteners. Do not use air or electric power tools as this increases the potential of thread galling.

1. Remove the spreader from the crate and remove the crating brackets from the bottom of the spreader.
2. Open the top cover of the spreader and remove the box containing the remote control.
3. Remove the right upper bolt from the power unit's steering column cover and discard.



4. Place a 1/4" flat washer onto the 1/4 x 3/4" flange bolt and insert the flange bolt through the hole in the control box mount bracket. Place another 1/4" flat washer onto the flange bolt and install in the right upper hole of the steering column cover with the flange of the control box mount bracket



hooked over the top edge or the steering column cover. Torque to 100 in-lbs (11 Nm).



5. Install the remote control transmitter onto the transmitter mount and clip the lanyard to the hole in the mount.
6. Adjust the transmitter mount to the desired angle.
7. Install the spreader hitch tube onto the spreader hitch mount using 4) 1/2 x 1-1/2" bolts, 8) 1/2" flat washers, and 4) 1/2" nylon lock nuts. Ensure

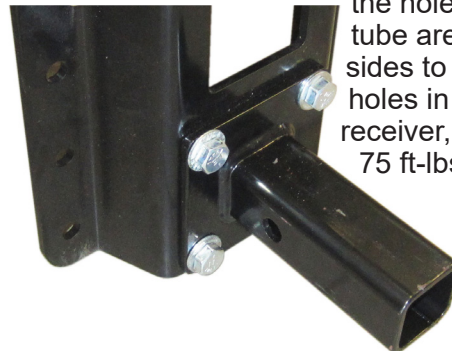

the holes in the hitch tube are turned to the sides to align with the holes in the hitch receiver, then torque to 75 ft-lbs (102 Nm).

SETUP

- Place 1) 1/2" flat washer on each of the 4) 1/2 x 3-3/4" bolts.
- Insert a 1/2 x 3-3/4" bolt into 1) hole on both of the small hitch plates and place the hitch plates onto the spreader cross tube as shown.



- Insert a 1/2 x 3-3/4" bolt into the bottom hole on both of the small hitch plates.



- Install the spreader hitch mount onto the 4) 1/2 x 3-3/4" bolts and fasten loosely with 4) 1/2" flat washers and 4) 1/2" nylon lock nuts.



NOTE: Ventrac recommends installing the hitch mount to the spreader using the top set of holes.

This provides maximum ground clearance when driving on and off sidewalks and curbs and also when loading and unloading power unit and spreader from a truck or trailer. If clearance is not an issue, you may mount the spreader closer to the ground. This will make it easier to load ice melt products into the spreader and also gives less time for wind to affect the spread pattern of the product being applied.

- Center the spreader hitch mount on the spreader tube by measuring from the outside edge of the spreader mount plate to the inside of the main frame end plates. Torque the 1/2" lock nuts to 75 ft-lbs (102 Nm).

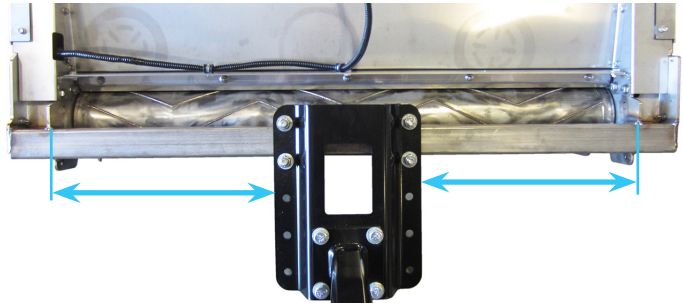

- Connect the 4 pin wire harness to the plug on the spreader harness.



- Slide the spreader hitch tube into the hitch receiver and fasten with the included clevis pin and hair pin.

- Route the harness through the cutout in the spreader hitch mount to keep it out of the path of the power unit's exhaust and insert the 4 pin plug on the spreader harness into the 12 volt rear socket on the power unit.

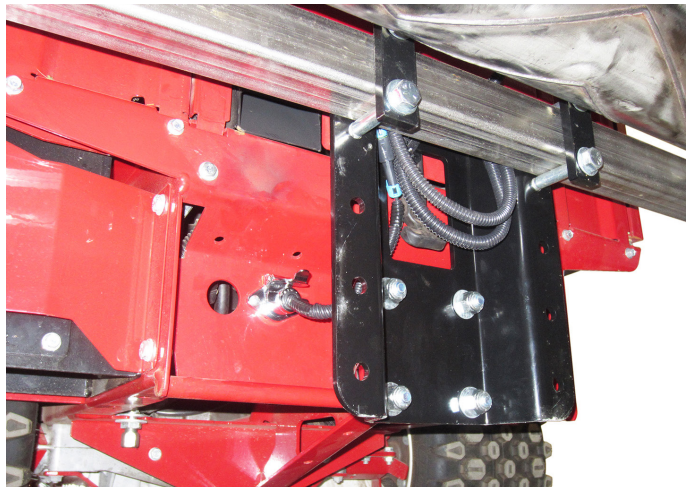

SETUP

16. Coil up the slack in the spreader harness and fasten to the spreader hitch mount using the included Velcro cable ties.
17. Tilt the power unit's seat forward and remove the front frame canvas that covers the area below the seat.

⚠ CAUTION

Power must be supplied to the SA250 spreader through a 20 amp fuse. Power supplied through a circuit breaker may result in damage to the spreader electronics. Replace any existing circuit breaker with a 20 amp fuse.

18. Remove the cover from the front fuse panel, remove the 15 amp fuse from position #5, and replace with the 20 amp fuse.

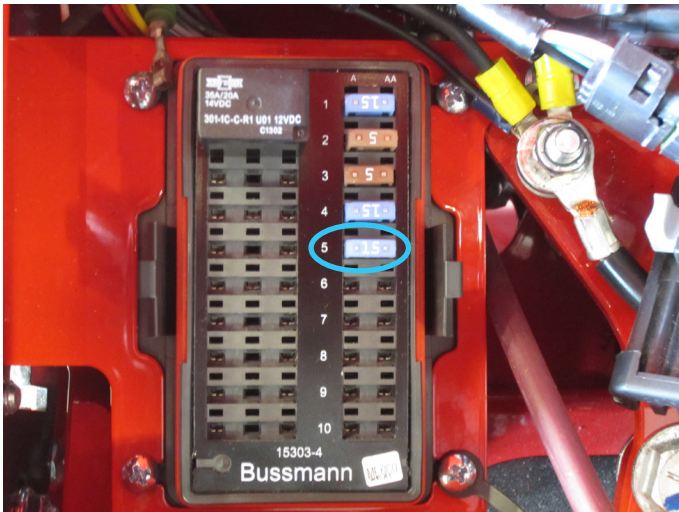

19. Reinstall the fuse panel cover.
20. Reinstall the front frame canvas onto the seat area and lower the seat back down to the operating position.

Installation is complete.

SETUP

SA250 Install 3100/3200 Kit

Document Number	Kit Number / Part Number	Model	Serial Number Range
09.700200	70.8151	LE3100	All Units
09.700200	70.8151	LE3200	All Units

⚠ WARNING

Before making repairs or adjustments set the parking brake, turn off engine, and remove ignition key. Always disconnect the negative battery cable from the battery when working with electrical components. Always work in a manner that does not put safety at risk!

⚠ WARNING

Safety glasses must be worn during installation. Ear (hearing) protection must be worn when using air or power tools.

Installation Notes: Right and left hand orientation referred to in these instructions is determined as if sitting on the tractor seat, facing forwards.

Installation Time (estimated) 1 hour

Tools Required: 3/8" wrench 7/16" wrench 3/4" wrench 3/4" socket ratchet drill 9/32" drill bit



Attention

To prevent thread galling, lubricate the bolt threads with a lithium complex NLGI #2 grease and use hand tools to tighten stainless steel fasteners. Do not use air or electric power tools as this increases the potential of thread galling.

⚠ CAUTION

Power must be supplied to the SA250 spreader through a 20 amp fuse. Power supplied through a circuit breaker may result in damage to the spreader electronics. Replace any existing circuit breaker with a 20 amp fuse.

1. Remove the spreader from the crate and remove the crating brackets from the bottom of the spreader.
2. Open the top cover of the spreader and remove the box containing the remote control.
3. Remove the right upper bolt from the power unit's steering column cover and discard.

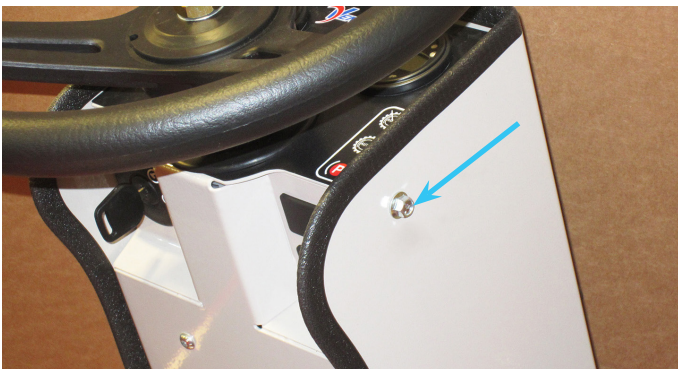

4. Place a 1/4" flat washer onto the 1/4 x 3/4" flange bolt and insert the flange bolt through the hole in the control box mount bracket. Place another 1/4" flat washer onto the flange bolt and install in the right upper hole of the steering column cover with the flange of the control box mount bracket hooked over the top edge or the steering column cover. Torque to 100 in-lbs (11 Nm).



5. Install the remote control transmitter onto the transmitter mount and clip the lanyard to the hole in the mount.
6. Adjust the transmitter mount to the desired angle.

SETUP

3100 Wiring Instructions

1. Open the engine hood.
2. Drill a 9/32" (7 mm) hole in the air intake top shield approximately 5" (12.5 cm) back from the front edge and 2" (5 cm) up from the bottom edge. Remove any metal shavings and use black touch up paint on the drilled hole.

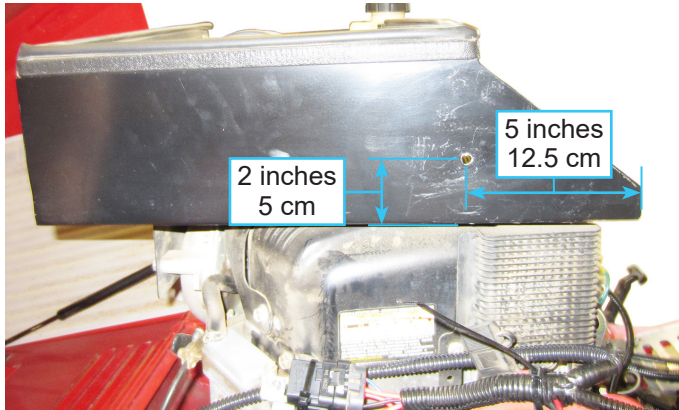

3. Mount the relay on the wire harness to the drilled hole using a 1/4 x 5/8" flange bolt, a 5/16" flat washer, and a 1/4" flange nut. Torque to 100 in-lbs (11 Nm).

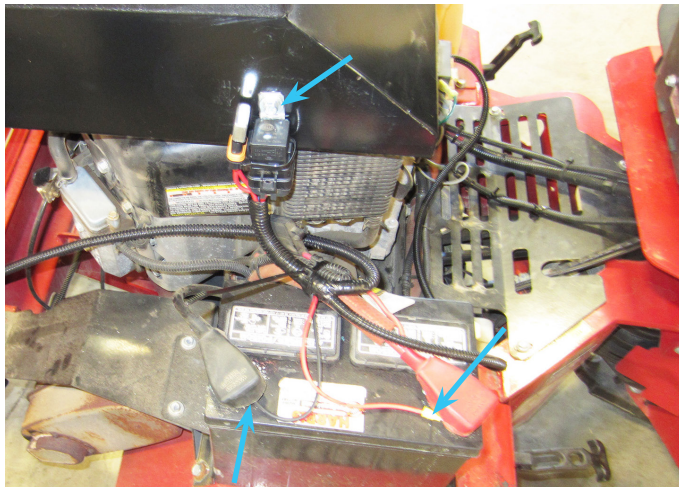

4. Connect the wire harness to the battery with the red wire attaching to the positive terminal and the black wire attaching to the negative terminal.

5. Remove the white wire with red stripe from position F on the fuse panel.

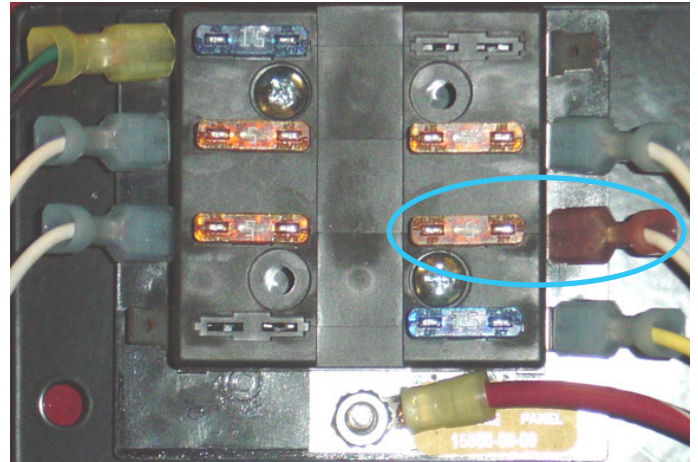

6. Install the push on terminal adapter onto the fuse block and connect the white wire with red stripe onto one of the adapter terminals.
7. Route the white wire from the relay along the power unit's wire harness to the fuse panel and connect to the adapter terminal. Fasten to the existing harness with zip ties.
8. Route the wire harness leg with the MP280 connector back along the frame to the right rear corner of the power unit.
9. Place the cushioned metal clamp over the harness just behind the end of the wire loom and fasten to the bottom of the hood frame using a 1/4 x 5/8" flange bolt and flange nut. Torque to 100 in-lbs (11 Nm).



10. Coil up any extra wire and use zip ties to secure the wire harness to the power unit.
11. Proceed to spreader setup and installation.

SETUP

3200 Wiring Instructions

1. Open the engine hood.
2. Drill a 9/32" (7 mm) hole in the muffler mount approximately 5/16" (8 mm) from the back edge and 2" (5 cm) down from the corner. Remove any metal shavings and use black touch up paint on the drilled hole.

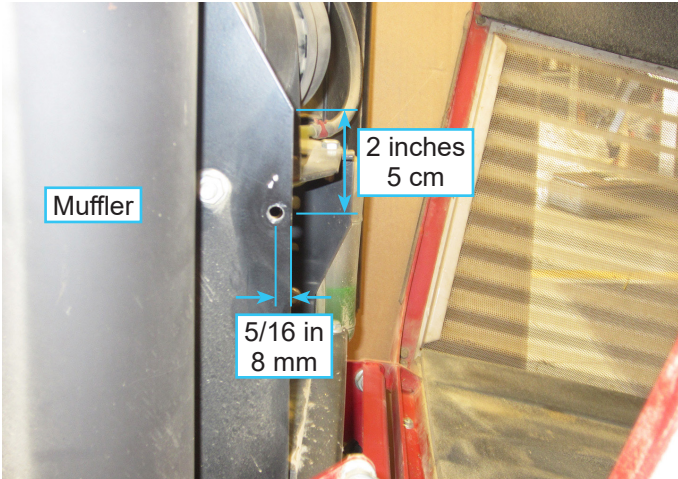

3. Mount the relay on the wire harness to the drilled hole using a 1/4 x 5/8" flange bolt, a 5/16" flat washer, and a 1/4" flange nut. Torque to 100 in-lbs (11 Nm).

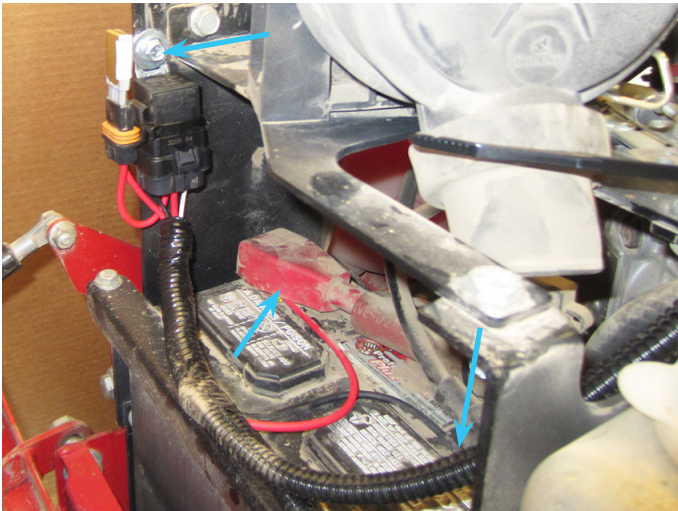

4. Connect the wire harness to the battery with the red wire attaching to the positive terminal and the black wire attaching to the negative terminal.
5. Remove the white wire with red stripe from position F on the fuse panel.

6. Install the push on terminal adapter onto the fuse block and connect the white wire with red stripe onto one of the adapter terminals.

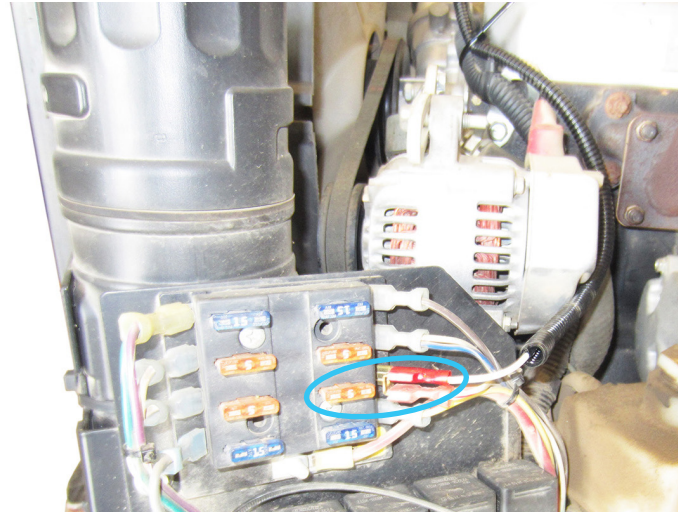

7. Route the white wire from the relay up through the air filter bracket, over the top of the engine following the current wire harness, and connect to the adapter terminal.
8. Use zip ties to fasten the wire to the existing wire harness and the air filter bracket.
9. Route the wire harness leg with the MP280 connector along the back of the frame to the right rear corner of the power unit.
10. Place the cushioned metal clamp over the harness just behind the end of the wire loom and fasten to the bottom of the hood frame using a 1/4 x 5/8" flange bolt and flange nut. Torque to 100 in-lbs (11 Nm).



11. Use a zip tie to fasten the wire harness to the battery clamp and tuck any excess wire down into the rear frame.

SETUP

Spreader Setup & Installation

1. Install the spreader hitch tube onto the spreader hitch mount using 4) 1/2 x 1-1/2" bolts, 8) 1/2" flat washers, and 4) 1/2" nylon lock nuts. Ensure the holes in the hitch tube are turned to the sides to align with the holes in the hitch receiver, then torque to 75 ft-lbs (102 Nm).

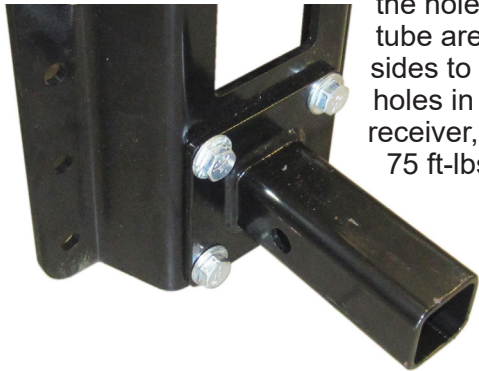

2. Place 1) 1/2" flat washer on each of the 4) 1/2 x 3-3/4" bolts.
3. Insert a 1/2 x 3-3/4" bolt into 1) hole on both of the small hitch plates and place the hitch plates onto the spreader cross tube as shown.



4. Insert a 1/2 x 3-3/4" bolt into the bottom hole on both of the small hitch plates.



5. Install the spreader hitch mount onto the 4) 1/2 x 3-3/4" bolts and fasten loosely with 4) 1/2" flat washers and 4) 1/2" nylon lock nuts.



NOTE: Ventrac recommends installing the hitch mount to the spreader using the top set of holes. This provides maximum ground clearance when driving on and off sidewalks and curbs and also when loading and unloading power unit and spreader from a truck or trailer. If clearance is not an issue, you may mount the spreader closer to the ground. This will make it easier to load ice melt products into the spreader and also gives less time for wind to affect the spread pattern of the product being applied.

6. Center the spreader hitch mount on the spreader tube by measuring from the outside edge of the spreader mount plate to the inside of the main frame end plates. Torque the 1/2" lock nuts to 75 ft-lbs (102 Nm).

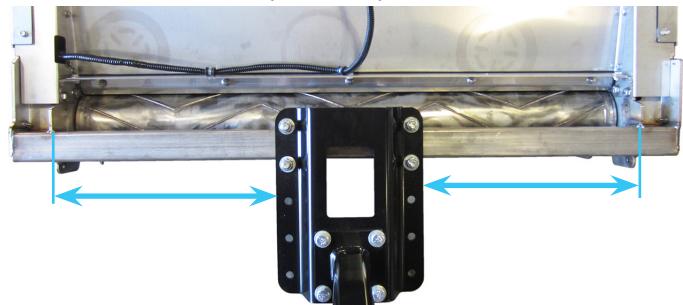

7. Slide the spreader hitch tube into the hitch receiver and fasten with the included clevis pin and hair pin.
8. Route the harness through the cutout in the spreader hitch mount and plug the connector on the spreader harness to the connector at the right rear corner of the power unit.
9. Coil up the slack in the spreader harness and fasten to the spreader hitch mount using the included Velcro cable ties.

Installation is complete.

SETUP

SA250 Install Universal 2" Receiver Kit

Document Number	Kit Number / Part Number	Model	Serial Number Range
09.700201	70.8142	-	-

⚠ WARNING

Before making repairs or adjustments set the parking brake, turn off engine, and remove ignition key.

Always disconnect the negative battery cable from the battery when working with electrical components. Always work in a manner that does not put safety at risk!

⚠ WARNING

Safety glasses must be worn during installation. Ear (hearing) protection must be worn when using air or power tools.

Installation Notes: Right and left hand orientation referred to in these instructions is determined as if sitting on the tractor seat, facing forwards.

Installation Time (estimated) 1 hour

Tools Required: 3/8" wrench 7/16" wrench 3/4" wrench 3/4" socket ratchet



Attention

To prevent thread galling, lubricate the bolt threads with a lithium complex NLGI #2 grease and use hand tools to tighten stainless steel fasteners. Do not use air or electric power tools as this increases the potential of thread galling.



Attention

Prior to drilling holes, check behind the mounting location to make sure you will not drill into wires, fuel lines, or any other components.



Attention

The SA250 spreader has a current draw of up to 12 amps. Before use, verify that your vehicle's charge system is capable of supplying an additional 12 amps of current.

4. Use the transmitter mount to mark the hole locations and drill 2) 9/32" (7 mm) holes.
5. Mount the transmitter bracket using 2) 1/4 x 5/8" flange bolts and 2) 1/4" flange nuts. Torque to 100 in-lbs (11 Nm).

⚠ CAUTION

Power must be supplied to the SA250 spreader through a 20 amp fuse. Power supplied through a circuit breaker may result in damage to the spreader electronics. Replace any existing circuit breaker with a 20 amp fuse.

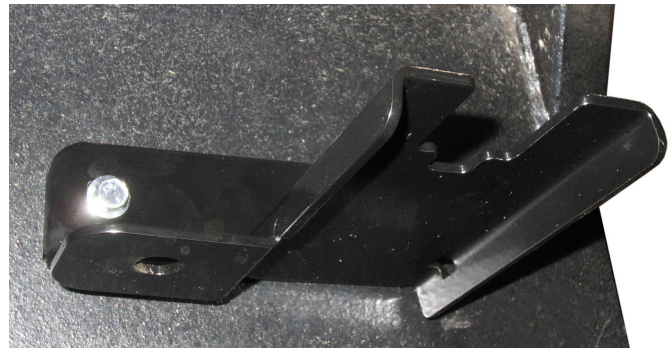

1. Remove the spreader from the crate and remove the crating brackets from the bottom of the spreader.
2. Open the top cover of the spreader and remove the box containing the remote control.

6. Install the toggle switch into the hole in the tab of the transmitter mount with the outer terminal down.

Transmitter Mount

3. Choose a convenient location to place the transmitter mount. Make sure the wire harness will reach from the battery to the desired mounting location.
NOTE: mounting location must be accessible from the back side in order to install hardware.

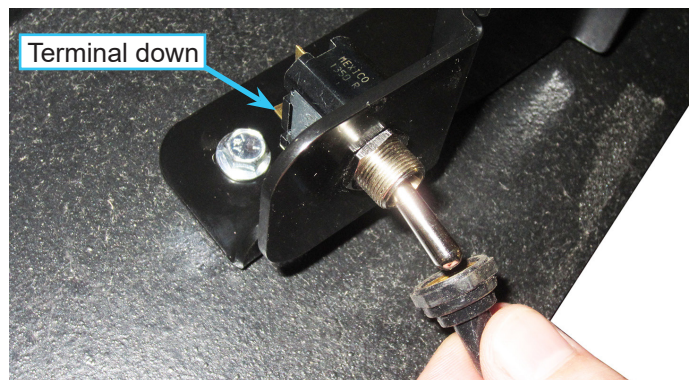

SETUP

7. Install the toggle switch boot onto the toggle switch.
8. Install the remote control transmitter onto the transmitter mount and clip the lanyard to the hole in the mount.



Electrical

9. Install the ring terminal on the **black** wire onto the **negative** battery terminal.
10. Install the ring terminal on the **red** wire onto the **positive** battery terminal.
11. Route the leg of the wire harness with the 2) push on connectors to the transmitter mount and connect to the toggle switch terminals.
NOTE: wires can be connected to either terminal. When routing harness, keep away from high temperature parts and moving parts.

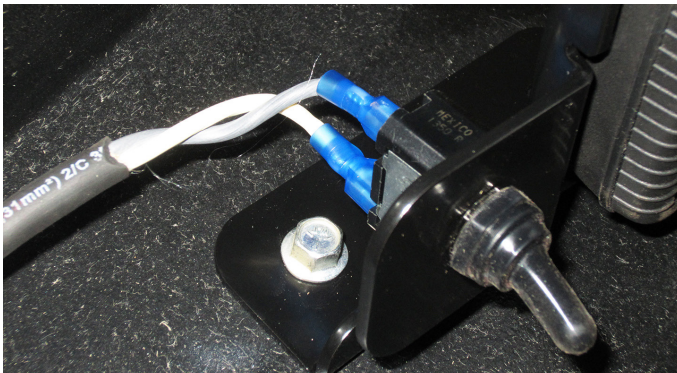

12. Route the leg of the wire harness with the MP280 connector to the rear of the vehicle. When routing harness, keep away from high temperature parts and moving parts.
13. Use a zip tie to fasten the harness and MP280 connector at a suitable location.
14. Coil up any excess wire in both legs of the wire harness and use zip ties to secure the harness away from sharp edges, high temperature parts, and moving parts.

Spreader Hitch

15. Install the spreader hitch tube onto the spreader hitch mount using 4) 1/2 x 1-1/2" bolts, 8) 1/2" flat washers, and 4) 1/2" nylon lock nuts. Ensure the holes in the hitch tube are turned to the sides to align with the holes in the hitch receiver, then torque to 75 ft-lbs (102 Nm).

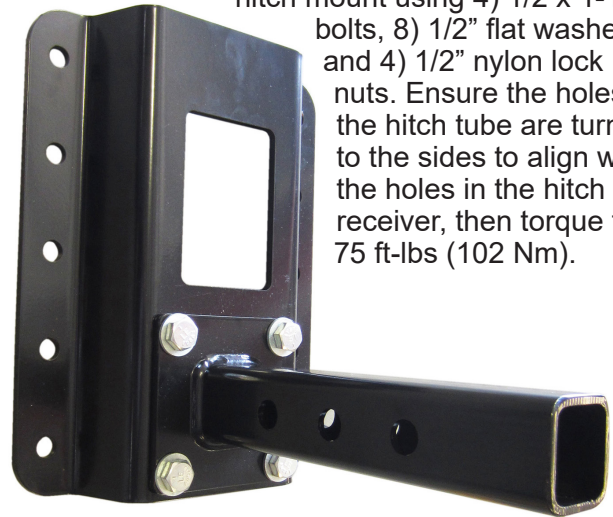

16. Place 1) 1/2" flat washer on each of the 4) 1/2 x 3-3/4" bolts.
17. Insert a 1/2 x 3-3/4" bolt into 1) hole on both of the small hitch plates and place the hitch plates onto the spreader cross tube as shown.



18. Insert a 1/2 x 3-3/4" bolt into the bottom hole on both of the small hitch plates.



SETUP

19. Install the spreader hitch mount onto the 4) 1/2 x 3-3/4" bolts and fasten loosely with 4) 1/2" flat washers and 4) 1/2" nylon lock nuts.

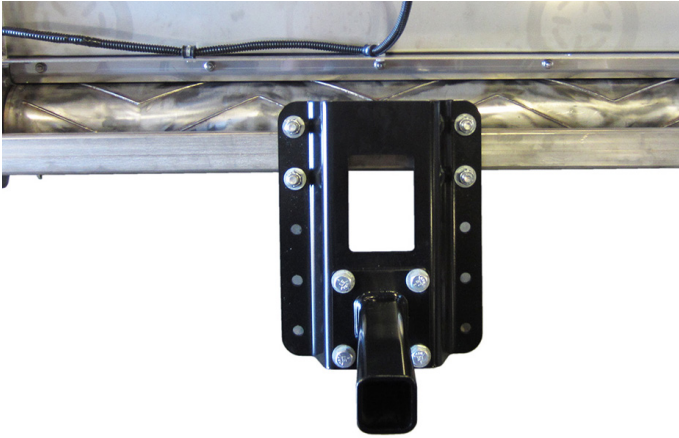

NOTE: Ventrac recommends installing the hitch mount to the spreader using the top set of holes. This provides maximum ground clearance when driving on and off sidewalks and curbs and also when loading and unloading power unit and spreader from a truck or trailer. If clearance is not an issue, you may mount the spreader closer to the ground. This will make it easier to load ice melt products into the spreader and also gives less time for wind to affect the spread pattern of the product being applied.

20. Center the spreader hitch mount on the spreader tube by measuring from the outside edge of the spreader mount plate to the inside of the main frame end plates. Torque the 1/2" lock nuts to 75 ft-lbs (102 Nm).

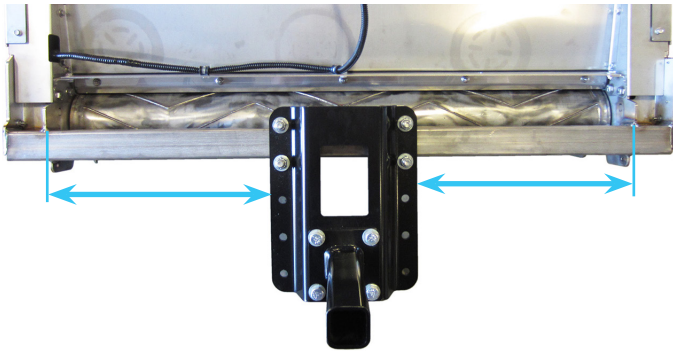

21. Slide the spreader hitch tube into the 2" hitch receiver and fasten with the included clevis pin and hair pin. Use the hole in the spreader hitch tube that positions the spreader closest to the vehicle without any contact between them.
22. Plug the connector on the spreader harness into the connector on the vehicle harness.

23. Coil up the slack in the spreader harness and fasten to the spreader mount plate using the included Velcro cable ties.

Installation is complete.

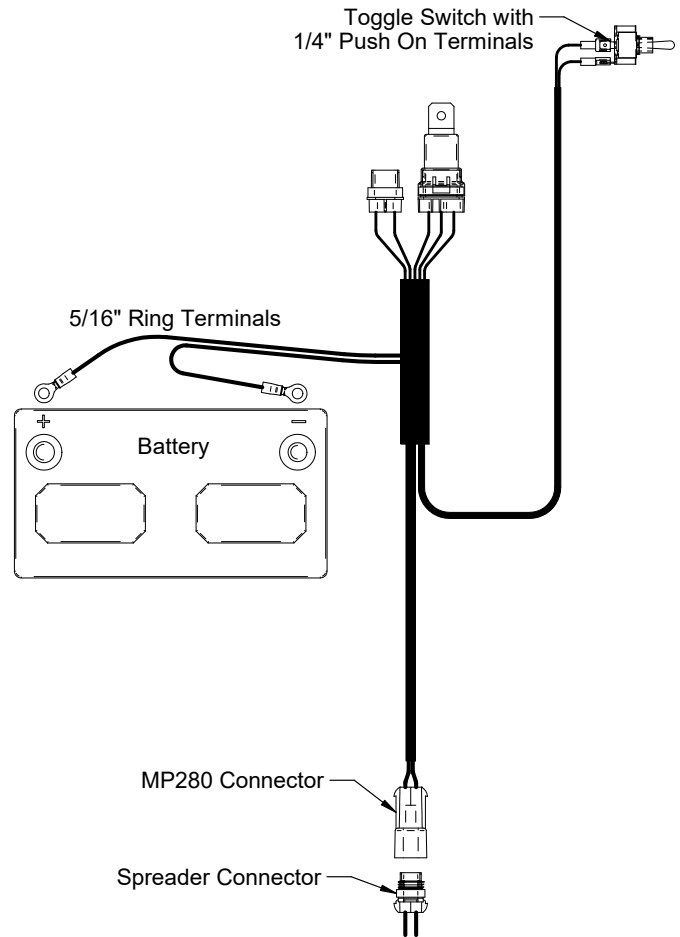

SETUP

SA250 Install Universal 3 Point Kit

Document Number	Kit Number / Part Number	Model	Serial Number Range
09.700202	70.8143	-	-

⚠ WARNING

Before making repairs or adjustments set the parking brake, turn off engine, and remove ignition key.

Always disconnect the negative battery cable from the battery when working with electrical components. Always work in a manner that does not put safety at risk!

⚠ WARNING

Safety glasses must be worn during installation. Ear (hearing) protection must be worn when using air or power tools.

Installation Notes: Right and left hand orientation referred to in these instructions is determined as if sitting on the tractor seat, facing forwards.

Installation Time (estimated) 1 hour

Tools Required: 3/8" wrench 7/16" wrench 9/16" socket ratchet



Attention

To prevent thread galling, lubricate the bolt threads with a lithium complex NLGI #2 grease and use hand tools to tighten stainless steel fasteners. Do not use air or electric power tools as this increases the potential of thread galling.



Attention

The SA250 spreader has a current draw of up to 12 amps. Before use, verify that your vehicle's charge system is capable of supplying an additional 12 amps of current.

⚠ CAUTION

Power must be supplied to the SA250 spreader through a 20 amp fuse. Power supplied through a circuit breaker may result in damage to the spreader electronics. Replace any existing circuit breaker with a 20 amp fuse.

1. Remove the spreader from the crate and remove the crating brackets from the bottom of the spreader.
2. Open the top cover of the spreader and remove the box containing the remote control.

Transmitter Mount

3. Choose a convenient location to place the transmitter mount. Make sure the wire harness will reach from the battery to the desired mounting location.
NOTE: mounting location must be accessible from the back side in order to install hardware.



Attention

Prior to drilling holes, check behind the mounting location to make sure you will not drill into wires, fuel lines, or any other components.

4. Use the transmitter mount to mark the hole locations and drill 2) 9/32" (7 mm) holes.
5. Mount the transmitter bracket using 2) 1/4 x 5/8" flange bolts and 2) 1/4" flange nuts. Torque to 100 in-lbs (11 Nm).



6. Install the toggle switch into the hole in the tab of the transmitter mount with the outer terminal down.



SETUP

7. Install the toggle switch boot onto the toggle switch.
8. Install the remote control transmitter onto the transmitter mount and clip the lanyard to the hole in the mount.



Electrical

9. Install the ring terminal on the **black** wire onto the **negative** battery terminal.
10. Install the ring terminal on the **red** wire onto the **positive** battery terminal.
11. Route the leg of the wire harness with the 2) push on connectors to the transmitter mount and connect to the toggle switch terminals.
NOTE: wires can be connected to either terminal. When routing harness, keep away from high temperature parts and moving parts.

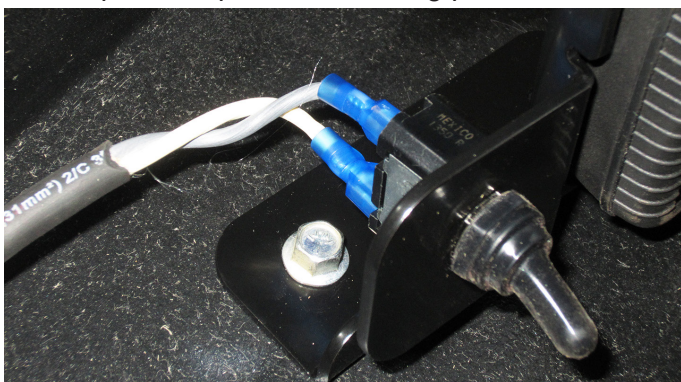

12. Route the leg of the wire harness with the MP280 connector to the rear of the vehicle. When routing harness, keep away from high temperature parts and moving parts.
13. Use a zip tie to fasten the harness and MP280 connector at a suitable location.
14. Coil up any excess wire in both legs of the wire harness and use zip ties to secure the harness away from sharp edges, high temperature parts, and moving parts.

Spreader Hitch

15. Install the 3 point top link spreader hitch (A) onto the spreader's square frame tube using 2) u-bolts and 4) 3/8" locking flange nuts. Center the top link hitch on the spreader tube by measuring from the outside edge of the top link hitch to the inside of the main frame end plates. Torque nuts to 31 ft-lbs (42 Nm).

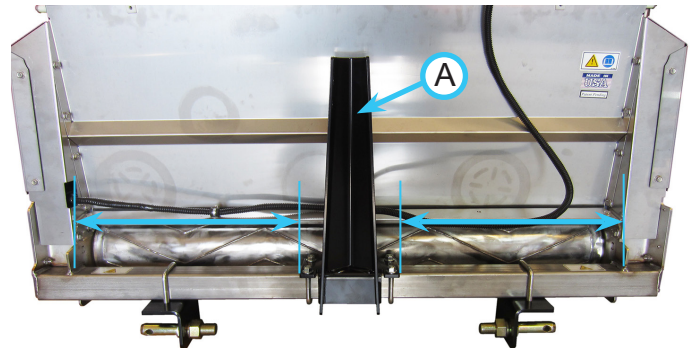

16. Install the left and right 3 point brackets with the pins facing outward onto the frame tube using 1) u-bolt and 2) 3/8" locking flange nuts for each bracket. Do not tighten.
17. Spread the attaching vehicles 3 point lift arms and measure the inside distance between the swivel ball ends.

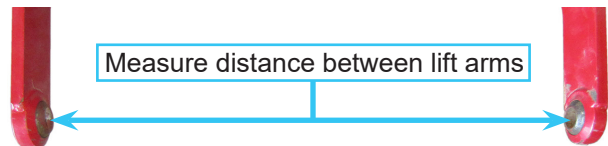

18. Set the left and right 3 point brackets so the distance between the outside end of the pins is 1" (2.5 cm) less than the distance measured in the previous step. Make sure the left and right brackets are centered with the 3 point top link hitch. Torque the nuts on the u-bolts to 31 ft-lbs (42 Nm).

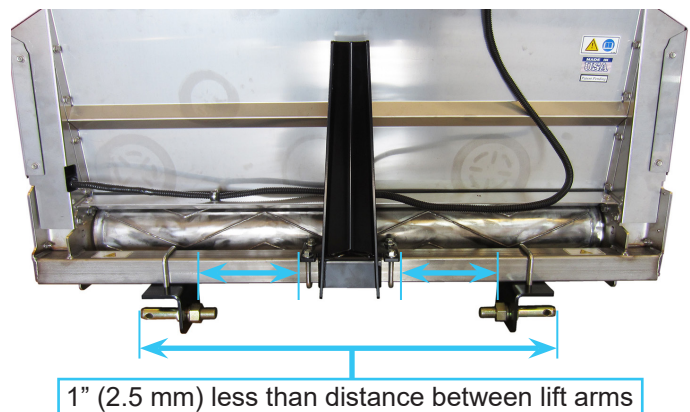

SETUP

19. Install the pins on the left and right 3 point brackets into the swivel balls on the 3 point lift arms and secure with linchpins.

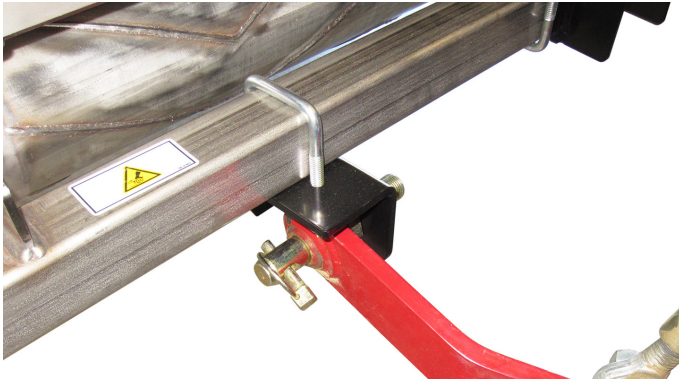

20. Insert the 3 point top link into the channel in the 3 point top link hitch, install the top link pin, and secure with a linchpin.



21. Plug the connector on the spreader harness into the connector on the vehicle harness.
22. Coil up the slack in the spreader harness and fasten to the top link spreader hitch using the included Velcro cable ties.

Installation is complete.

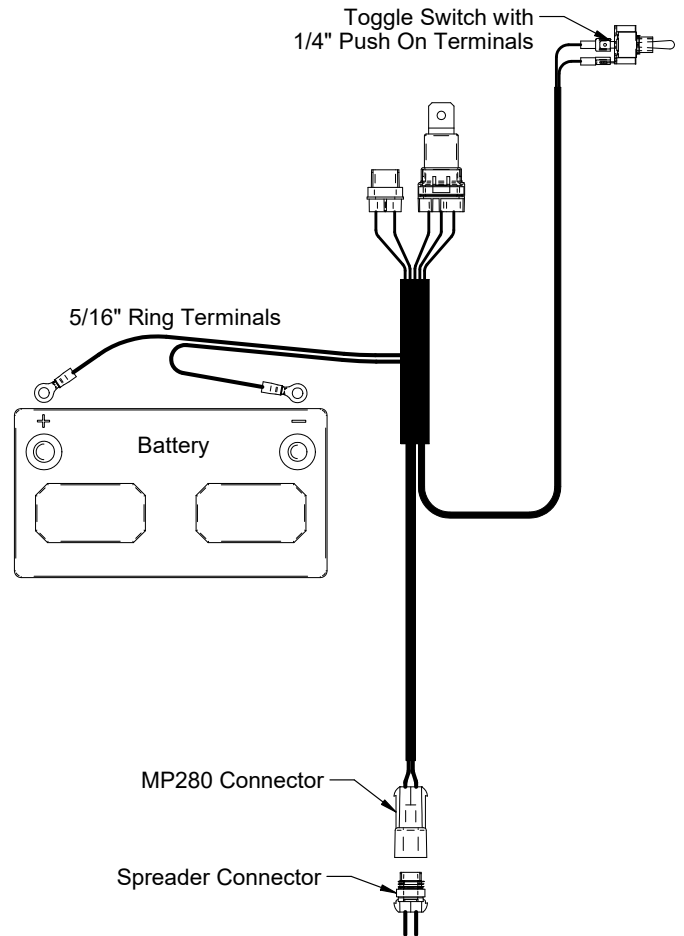

OPERATIONAL CONTROLS

Transmitter (Remote Control)

The remote control transmitter works with the controller unit (receiver) to wirelessly control the operation of the drop spreader.



the current speed setting. This will stop the spreader without turning off the controller, allowing the operator to restart the spreader by pressing the desired speed button.

Pressing the Off button will stop the spreader and turn off the controller. When the controller has been shut off, the controller will need to be restarted using the remote control's On button, then pressing the desired speed setting.

The remote control is equipped with a low battery indicator (B) to notify the operator that it is time to replace the battery.

Hopper Cover Strap

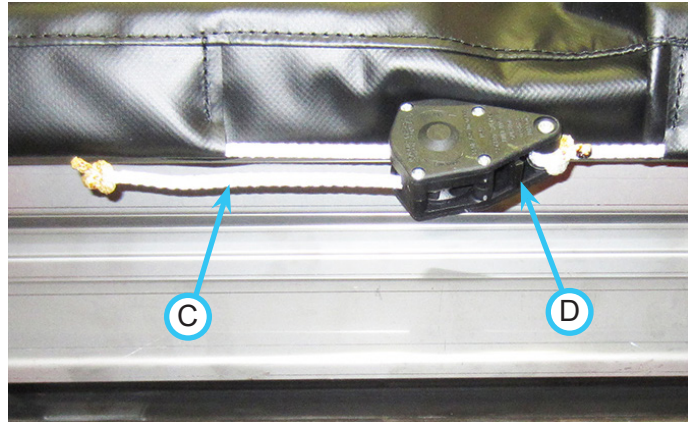

After placing the hopper cover over the hopper, pull out on the cord (C) to cinch the cover in place. Push in on the ratchet latch (D) to release the cord and remove the cover.

Press and hold the On button until the power on indicator flashes (approximately 1 second) to turn on the control unit.

The controller is equipped with five speed settings. To start the spreader, select the desired speed setting (1-5). Button #1 is the minimum speed setting and button #5 is the maximum speed setting. The indicator light(s) for the selected speed setting will light up to show the selected speed.

Button #6 is burst mode, which activates maximum speed for as long as the button is pushed. When the button is released, the controller will return to the previously selected speed setting.

To stop the spreader, press the button that matches

GENERAL OPERATION

Daily Inspection

WARNING

Always set the parking brake, shut off power unit engine, remove the ignition key, unplug the spreader from the vehicle power supply, and ensure all moving parts have come to a complete stop before inspecting components, or attempting any repair or adjustment.

1. Park machine on a level surface, with the engine shut off and all fluids cold.
2. Perform a visual inspection of both the power unit and the drop spreader. Look for loose or missing hardware, damaged components, or signs of wear.
3. Ensure electrical connections are tight and clean.
4. Check to ensure nothing is jammed in the hopper.
5. Refer to the power unit operator's manual. Check the power unit's engine oil, hydraulic oil, cooling system, tire pressure, and fuel level. Add fluid or service as required.
6. Test the power unit's operator safety interlock system*.

Attaching (Receiver Hitch)

CAUTION

When possible, use a crane or forklift to lift the spreader. If the spreader must be lifted manually, ask someone to assist you.

1. Park the power unit on a level surface.
2. Engage the parking brake, and shut off the power unit's engine.
3. Lift the spreader (with assistance) and slide the spreader hitch into the hitch receiver tube on the power unit and fasten in place with a clevis pin and hairpin.
4. Connect electric plug on the spreader harness to the power unit's connector.

* Refer to power unit operator's manual for operation of power unit controls.

Detaching (Receiver Hitch)

WARNING

Do not attempt to remove the spreader from the power unit while there is still material in the spreader hopper.

1. Park the power unit on a level surface.
2. Engage the parking brake, and shut off the power unit's engine.
3. Disconnect the spreader harness from the power unit's connector.
4. Remove the clevis pin from the power unit's hitch receiver tube, lift up on the spreader (with assistance) and slide the spreader hitch out of the receiver tube.

Attaching (3-Point Hitch)

CAUTION

When possible, use a crane or forklift to lift the spreader. If the spreader must be lifted manually, ask someone to assist you.

1. Park the power unit on a level surface.
2. Engage the parking brake, and shut off the power unit's engine.
3. Insert the lift arm pins into the swivel balls on the 3-point lift arms and secure with linch pins.
4. Insert the 3-point top link into the top link hitch plate, install the top link pin, and secure with a linch pin.
5. Connect electric plug on the spreader harness to the power unit's connector.

Detaching (3-Point Hitch)

WARNING

Do not attempt to remove the spreader from the power unit while there is still material in the spreader hopper.

1. Park the power unit on a level surface.
2. Engage the parking brake, and shut off the power unit's engine.
3. Disconnect the spreader harness from the power unit's connector.
4. Remove the top link pin from the top link hitch plate.
5. Remove the linch pins from the lift arm pins and slide the lift arm pins out of the lift arm swivel balls to remove.

GENERAL OPERATION

Spreader Loading

WARNING

Do not overload spreader or power unit. Use the chart below to calculate weight of material. Weights of material are an average for dry materials.

WARNING

If using the spreader in combination with a vehicle that is not made by Ventrac, do not exceed the manufacturer's Gross Vehicle Weight Rating (GVWR). Overloading will result in unpredictable and/or unsafe vehicle handling and may cause damage to the equipment.

Material	Weight per Cubic Ft.
Rock Salt	75-85 lbs. (34-38.5 kg)
Sand/Salt Mix	95-120 lbs. (43-54.5 kg)
Maximum Spreader Capacity (Volume)	
Standard	With Hopper Extension
2.5 ft ³ (71 dm ³)	5 ft ³ (142 dm ³)
Maximum Spreader Capacity (Weight)	
Standard	With Hopper Extension
200 lbs. (91 kg)	400 lbs. (181 kg)

Use the following charts to determine the allowable weight capacity of the spreader in combination with various power unit and attachment setups.

WARNING

Exceeding the listed weight capacities for your power unit and attachment combination may result in loss of steering or front wheel traction.

Ventrac 3000 series power unit (without cab) *			
Attachment On Front Of Power Unit		Spreader Capacity	
		Standard	W/Hopper Ext. ^{&}
HE480	48" Slip Scoop	*	Not Applicable
HJ480	48" Excavator	*	Not Applicable
KD482	48" Dozer Blade	*	Not Applicable
KD602	60" Dozer Blade	100 lbs (45 kg) #	Not Applicable
KD722	72" dozer Blade	100 lbs (45 kg) #	Not Applicable
KV552	55" V-Blade	150 lbs (68 kg) #	Not Applicable
LB540	54" Broom	150 lbs (68 kg) #	Not Applicable
LX423	42" Snowblower	200 lbs (91 kg) ^	Not Applicable

Ventrac 3000 series power unit (with cab) *			
Attachment On Front Of Power Unit		Spreader Capacity	
		Standard	W/Hopper Ext. ^{&}
HE480	48" Slip Scoop	100 lbs (45 kg) #	Not Applicable
HJ480	48" Excavator	100 lbs (45 kg) #	Not Applicable
KD482	48" Dozer Blade	100 lbs (45 kg) #	Not Applicable
KD602	60" Dozer Blade	150 lbs (68 kg) #	Not Applicable
KD722	72" dozer Blade	150 lbs (68 kg) #	Not Applicable
KV552	55" V-Blade	200 lbs (91 kg) ^	Not Applicable
LB540	54" Broom	200 lbs (91 kg) ^	Not Applicable
LX423	42" Snowblower	200 lbs (91 kg) ^	Not Applicable

* If power unit is equipped with optional weights, the weights must be removed from the power unit.

* Attachments weighing less than 200 lbs (91 kg) are not recommended for use with the spreader in this configuration.

Weight transfer set to medium setting.

^ Weight transfer set to high setting.

& Hopper extension should not be used on the Ventrac 3000 series power units.

Ventrac 4000 series power unit (without cab)			
Attachment On Front Of Power Unit		Spreader Capacity	
		Standard	W/Hopper Ext.
HE480	48" Slip Scoop	200 lbs (91 kg) &	300 lbs (136 kg) &
HJ480	48" Excavator	200 lbs (91 kg) &	300 lbs (136 kg) &
KD482	48" Dozer Blade	200 lbs (91 kg) &	300 lbs (136 kg) &
KD602	60" Dozer Blade	200 lbs (91 kg) &	350 lbs (159 kg) &
KD722	72" dozer Blade	200 lbs (91 kg) &	350 lbs (159 kg) &
KV552	55" V-Blade	200 lbs (91 kg) &	400 lbs (181 kg) &
HB580	58" Broom	200 lbs (91 kg) ^	400 lbs (181 kg) ^
KX523	52" Snowblower	200 lbs (91 kg) ^	400 lbs (181 kg) ^

Ventrac 4000 series power unit (with cab) &			
Attachment On Front Of Power Unit		Spreader Capacity	
		Standard	W/Hopper Ext.
HE480	48" Slip Scoop	150 lbs (68 kg)	150 lbs (68 kg)
HJ480	48" Excavator	150 lbs (68 kg)	150 lbs (68 kg)
KD482	48" Dozer Blade	150 lbs (68 kg)	150 lbs (68 kg)
KD602	60" Dozer Blade	200 lbs (91 kg)	200 lbs (91 kg)
KD722	72" dozer Blade	200 lbs (91 kg)	200 lbs (91 kg)
KV552	55" V-Blade	200 lbs (91 kg)	250 lbs (113 kg)
HB580	58" Broom	200 lbs (91 kg) ^	400 lbs (181 kg) ^
KX523	52" Snowblower	200 lbs (91 kg) ^	400 lbs (181 kg) ^

& The rear weights must be removed from the power unit.

^ Weight transfer set to high (maximum).

1. Park power unit on a level surface and turn off the spreader controller.
2. Engage the parking brake and shut off the power unit's engine.
3. Open the hopper cover.

GENERAL OPERATION

- Pour or shovel the proper amount of ice melt material into the spreader hopper.
- Replace and secure the hopper cover.

Spreader Operation

WARNING

Do not operate power unit and spreader on slopes greater than 10 degrees. Operation on slopes greater than 10 degrees may result in loss of steering or front wheel traction.

WARNING

Do not exceed 10 mph (16 kph) when operating the spreader.

WARNING

Always turn off the spreader controller before filling the hopper with material.

WARNING

Before working on the spreader for any reason, turn off the spreader controller and unplug the spreader from the vehicle's power supply.

Press the On button on the remote control transmitter to turn the controller on. When in position to start spreading, press the desired speed button to start the spreader. The spreader speed can be changed at anytime by selecting the desired speed button.



Attention

The speed of the power unit, the type of material used, moisture content of material, and desired application rate will determine the necessary controller speed and gate settings of the spreader. If you cannot achieve the desired application using the controller speed options, you will need to adjust the gate settings. Refer to the Gate Adjustment section for adjustment instructions.

If more material is needed in a small area, press and hold the blast button (#6) to increase the application rate by running the spreader at full speed. Release the blast button to return to normal spreading speed.

NOTE: the blast feature will only work when the controller is set to less than the maximum speed (#5).

To pause spreading for just a short period, press the current speed button. Press the desired speed button to restart the spreader.

Between jobs, turn off the spreader controller by pressing the Off button on the remote control.

The spreader controller will automatically turn off after 30 minutes with no remote control activity.

CAUTION

Never leave materials in the hopper for long periods of time, as ice melt products are hygroscopic and will attract atmospheric moisture and harden.

When spreading is complete, empty the spreader hopper to prevent the ice melt material from hardening or forming clumps inside the hopper.

Application Rates

Use of excessive amounts of ice melt products increases the cost of treatment and could harm vegetation due to run off of materials. For these reasons, it is best to use the minimum amount of material necessary to achieve the desired results.

Rate Chart lbs/minute (kg/minute)

Material	Minimum Rate	Maximum Rate
Rock Salt (Bagged)	4 lbs/min (1.8 kg/min)	60 lbs/min (27.2 kg/min)
Rock Salt (Bulk)	5 lbs/min (2.3 kg/min)	75 lbs/min (34 kg/min)
Ice B Gone	10 lbs/min (4.5 kg/min)	60 lbs/min (27.2 kg/min)
Calcium Chloride Pellets	12 lbs/min (5.4 kg/min)	45 lbs/min (20.4 kg/min)

Rate Calculation

A = pounds per minute

S = speed (Mph)

R = pounds per 1,000 square feet.

Formula to calculate pounds per 1,000 square feet from measured pounds per minute is:

$$R = 3.409 \times \frac{A}{S}$$

Formula to calculate pounds per minute from desired pounds per 1,000 square feet is:

$$A = \frac{R \times S}{3.409}$$

GENERAL OPERATION

Gate Adjustment

⚠ WARNING

Before making adjustments to the spreader, turn off the spreader controller and unplug the spreader from the vehicle's power supply.



Attention

To prevent thread galling, hand tools and a thread lubricant are recommended when tightening stainless steel fasteners. Do not use air or electric power tools as this increases the risk of thread galling.

There are two different adjustments that can be made to the gate. The gate link (A) can be adjusted on the arm (B) of the gate control rocker to increase or decrease the amount of gate travel for each motor revolution.

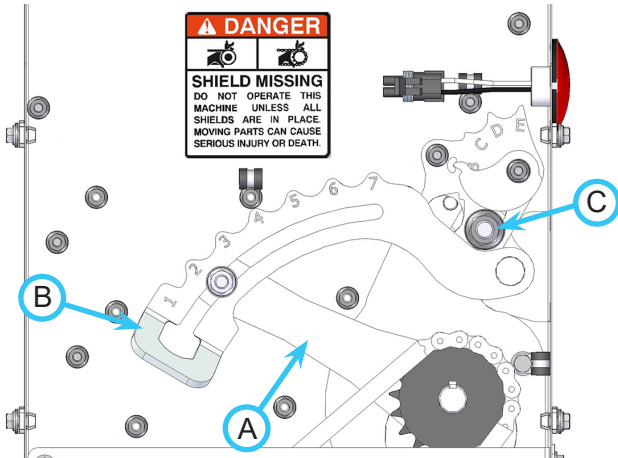

The gate control rocker mounting bolts (C) can be adjusted to increase or decrease the overall opening of the gate.

If application rate adjustments need to be made, adjust the gate link first. If the gate link adjustments are not enough to achieve the desired result, adjust the gate control rocker position.

Gate Travel Adjustment

1. Remove the left side cover from the spreader.
2. Loosen the nut that fastens the gate link to the gate control rocker arm.
3. Slide the gate link to the desired position (setting #1 is the minimum amount of gate travel with the lowest flow rate, setting #7 is the maximum amount of gate travel with the highest flow rate).
4. Retighten the nut and torque to 31 ft-lbs (42 Nm).
5. Reinstall the left side cover.

Gate Opening Adjustment

1. Remove both the left and right side covers.
2. Note the location of the left and right gate indicator plates (D).

S ALL PLACE. V CAUSE ? DEATH.

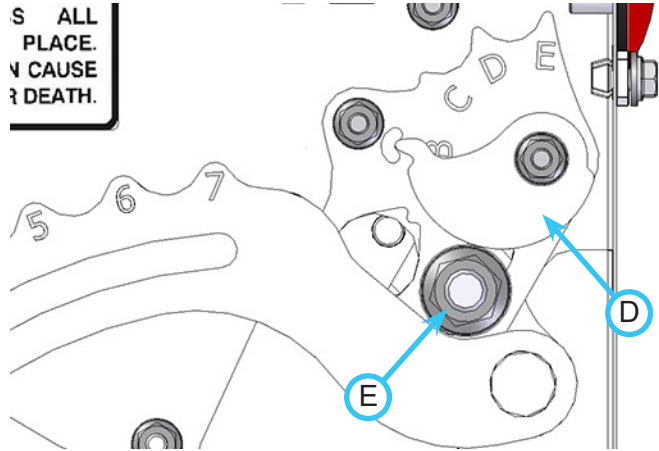

3. Loosen the nuts (E) that fasten the gate control rocker to the end panels and stiffener plates.
4. Slide the gate control rocker up or down to the desired location (setting A is the minimum gate opening with least amount of material flow, setting E is the maximum gate opening with the greatest amount of material flow).

⚠ WARNING

Check to ensure clearance between the bottom of the gate and the rotor.

If the gate contacts the rotor, the rotor could jam and cause damage to the motor or controller.

5. Tighten the gate control rocker nuts slightly. Rotate the left and right indicator plates down until they are resting against the washers on the gate control rocker mounting bolts. Check the left and right indicator plate settings. If the indicators are aligned (ex. both at the tab for setting C), then the rocker shaft is level. If the indicator plates are not aligned, adjust one end of the gate control rocker until the indicator plates align.
6. After both indicator plates are aligned, torque the nuts to 75 ft-lbs (102 Nm).
7. Reinstall the left and right side covers.

SERVICE

⚠ WARNING

Always set the parking brake, shut off power unit engine, remove the ignition key, and ensure all moving parts have come to a complete stop before inspecting components or attempting any repair or adjustment.

Before attempting any repairs or adjustments to the spreader, turn off the controller and unplug the spreader from power supply.

⚠ WARNING

When servicing is necessary, perform it in a protected area. Do not use power tools in rain or snow because of danger of electrical shock or injury. Perform service in a well lighted area. Keep service area clean to help prevent accidents.

⚠ WARNING

Do not splice any other devices into wiring harness.

⚠ CAUTION

Read lead labels before attaching wiring harness to power source or ground.

⚠ CAUTION

The controller is an electronic unit and is not serviceable. Any attempt to service will void the warranty.

⚠ CAUTION

There are no serviceable parts in the motor/transmission assembly.



Attention

If any spreader component requires replacement, use only original Ventrac replacement parts.



Attention

To prevent thread galling, hand tools and a thread lubricant are recommended when tightening stainless steel fasteners. Do not use air or electric power tools as this increases the risk of thread galling.

Cleaning and General Maintenance

The spreader is constructed of stainless steel panels, along with the majority of components and hardware, to prevent corrosion from salt. Dirt and salt deposits can affect the performance of the spreader.

For best results and performance, clean or wash the spreader to prevent accumulations of dirt, sand, and salt. Remove any ice or snow accumulations from the spreader and hitch mount.



Attention

To maintain the finish of the power unit and attachment, thoroughly wash the equipment after each use to remove any corrosive agents (e.g., salt). Failure to clean the equipment may result in corrosion of (including but not limited to) steel, aluminum, and electrical components. Equipment that will experience repeated exposure to corrosive agents should be pretreated with a corrosion preventative.

⚠ CAUTION

When pressure washing the motor area, stay at least 36 inches (92 cm) away from the motor.

Service Access Points

Throughout the manual, different access points are referred to. The following list and images identify shields and covers that may need to be removed for service and adjustments.

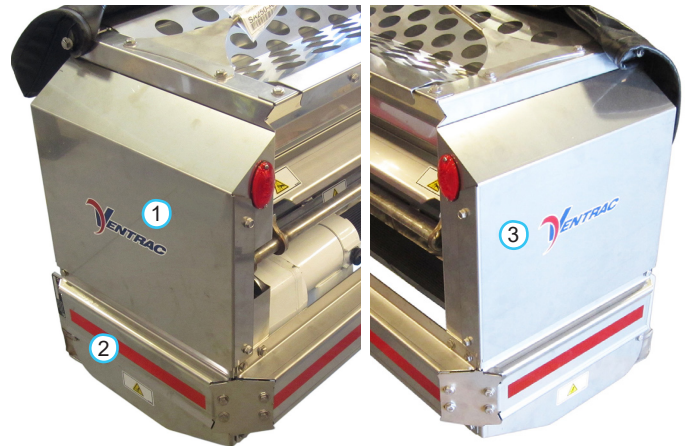

1. Left Side Panel
2. Left Bumper

3. Right Side Panel

SERVICE

Lubrication Locations

Lubrication is required at the following locations. Use a Lithium Complex NLGI #1 type grease or a Lithium Complex NLGI #2 type grease rated for -40° F (-40° C). Refer to the maintenance schedule for service intervals and amount of grease.

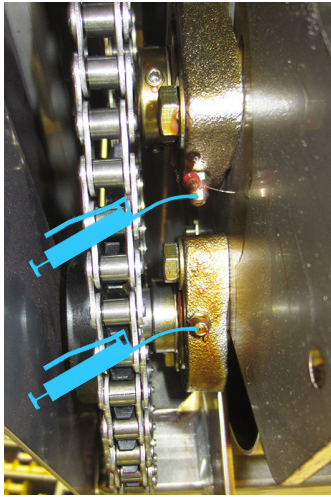

Left bearings

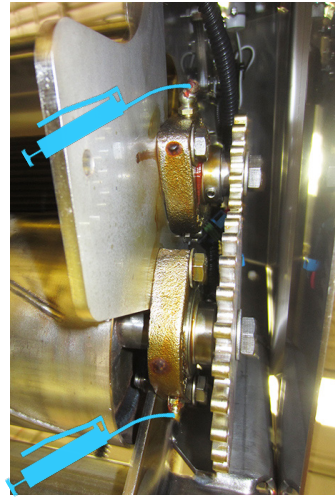

Right bearings

Motor Oil Level

For normal service, periodic motor oil level checks are not required. When performing the daily inspection, check the exterior surface of the motor for oil leakage. If oil leakage is suspected, check the motor oil level.

1. Remove the left side panel from the spreader.
2. Remove the fill port plug (A) from the end of the motor. The oil level should be even with the bottom of the fill port to 1/4" (6.5 mm) below the fill port.

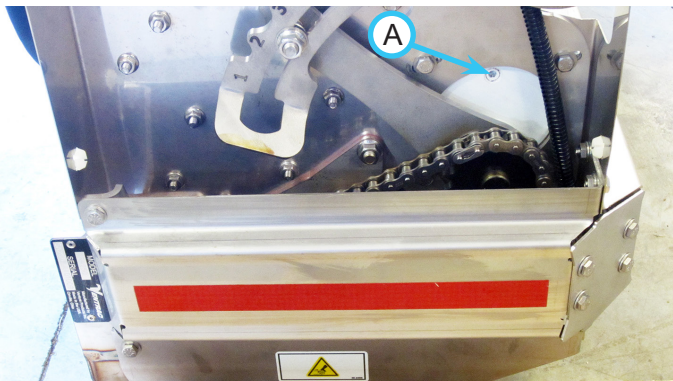

If a motor oil leak is confirmed, the motor must be repaired by an authorized Ventrac dealer.

Changing The Motor Oil

1. Remove the spreader from the power unit and place on a level surface.
2. Remove the left side panel from the spreader.
3. Place a 4x4 block (A) on the floor next to the left bumper. Stack 2 4x4 blocks (B) on the floor with approximately 14" (35.5 cm) in between the double blocks and the first block.

End of top block must be inside the bolt for the top cover.

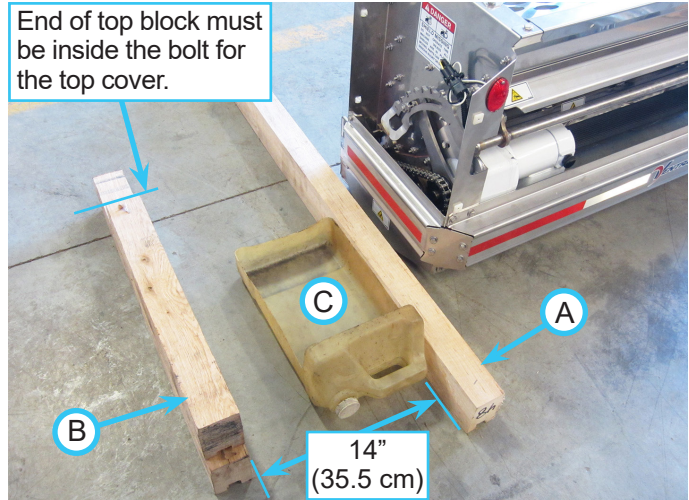

4. Place a shallow drain pan (C) next to the single block.
5. Place some shop rags or hand towels on the blocks to prevent surface scratches and/or damage to the reflective tape.
6. Remove the plug (D) from the end of the motor.

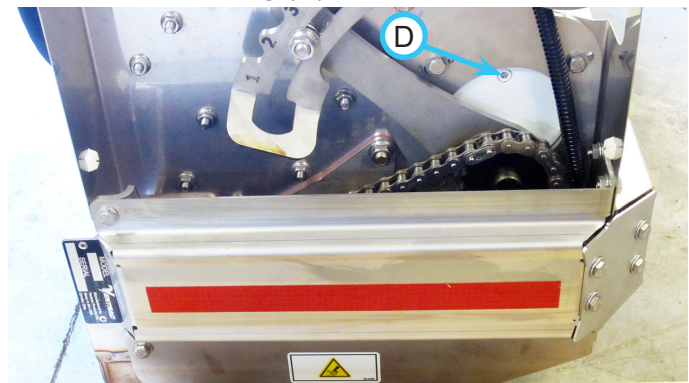

7. Lift the opposite end of the spreader until the left bumper is setting on the single block.

SERVICE

- Set the upper left end of the spreader hopper onto the double blocks, making sure that the taillight wires and connectors do not get pinched between the blocks and the spreader. Make sure the spreader is setting on the end of the hopper, not on the top cover bolt.

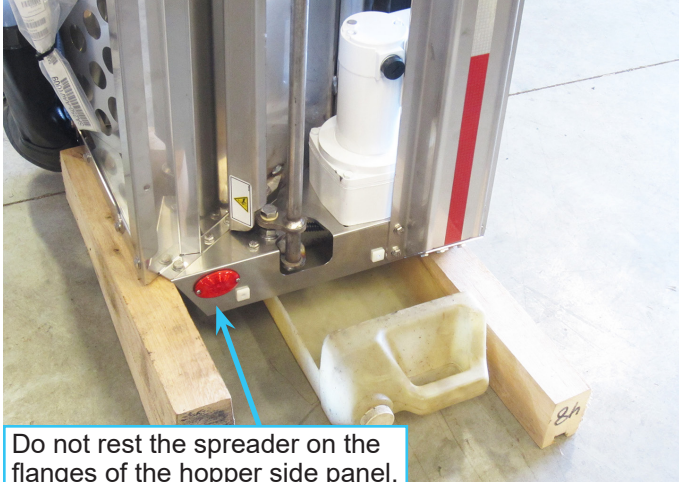

- Allow the oil to drain from the motor (may take up to 1/2 hour).
- Lower the right end of the spreader until it is setting on the floor.
- Wipe up any spilled oil from the spreader and the floor.
- Add 12 oz (350 cc) of Ventrac HydroTorq XL synthetic oil to the motor. Oil level should be at the bottom of the fill port to 1/4" (6.5 mm) below the fill port.

⚠ Attention: Oil Recommendation

For optimal motor life and performance, use Ventrac HydroTorq XL synthetic oil.

- Reinstall the fill port plug.
- Reinstall the left side panel.

Drive Chain

Apply chain oil to the drive chain and wipe up all drips and spills. Refer to the maintenance schedule for service intervals.

Drive Chain Tension Inspection

- Unplug the spreader from the power supply.
- Remove the left side panel from the spreader.
- Remove the left bumper from the spreader.
- Place a straightedge across the bottom of the sprockets as shown.

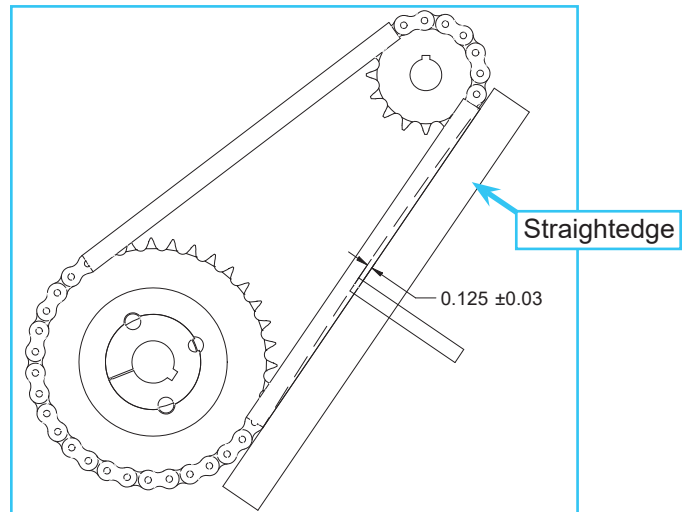

- Lightly press on the chain at the center point between the sprockets to remove the slack. There should be 1/8" ± 1/32 (3 mm ± 1 mm) between the chain and the straightedge.
- If the chain tension needs adjusted, proceed to the following section of chain tension adjustment. If chain tension is correct, reinstall the left bumper and the left side panel.

Drive Chain Tension Adjustment

- Loosen the 4) motor mount bolts.
- Move the motor to increase or decrease the chain tension and torque the motor mount bolts to 115 in-lbs (13 Nm).
- Reconnect the spreader to the power supply and run the spreader for 20 to 30 seconds.
- Unplug the spreader from the power supply and recheck the tension.
- When chain tension is correct, reinstall the left bumper and the left side panel.

SERVICE

Controller Bypass

In the event of a controller malfunction, the controller unit can be bypassed to allow spreader operation. If the controller is bypassed, the spreader will run at only one speed (maximum speed) and will have to be controlled by turning the power supply on or off.

To bypass the controller unit:

1. Unplug the spreader from the power supply.
2. Remove the right side panel from the spreader.
3. Unplug the power supply wire harness from the controller unit connector.

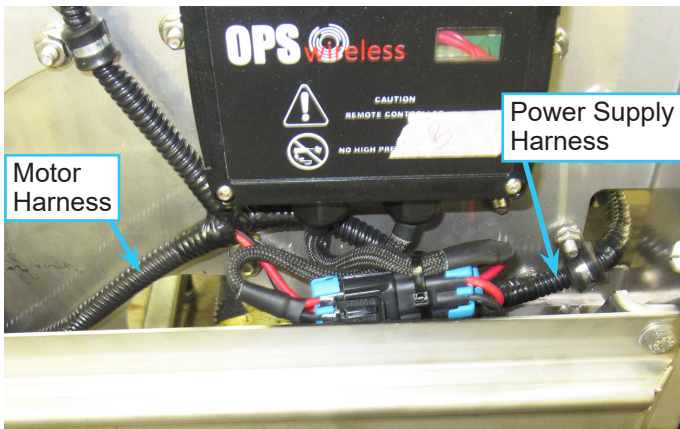

4. Unplug the motor harness from the controller unit connector and plug the motor wire harness connector and the power supply wire harness connector together.
5. Reinstall the right side panel.
6. Reconnect the spreader to the power supply.
NOTE: if the power supply runs through a switch, use the switch to turn the spreader on or off. If the power supply connects directly to the battery, you will have to disconnect the harness to stop the spreader.

Synchronizing Remote Transmitter To Controller Unit

The remote transmitter and the controller unit (receiver) for your spreader come as a matched pair. If you ever need to replace either component, you will need to follow the synchronizing (pairing) procedure to create a unique assignment between the remote transmitter and the controller unit.

1. Disconnect power to the controller unit.
2. Remove the right side cover from the spreader.
3. Remove the front cover from the controller unit.
4. Locate the jumper terminals in the lower right corner of the controller unit.

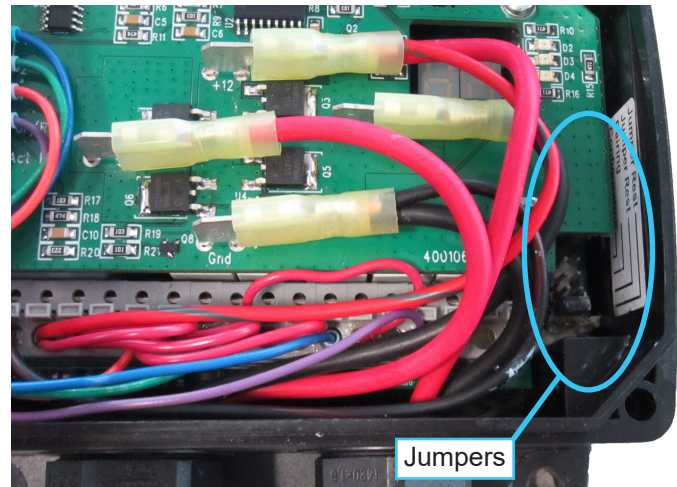

5. Remove one of the two jumpers from the jumper rest positions and install it in the pairing position. Refer to label inside controller housing.
6. Press button #1 and button #3 on the remote control at the same time. The middle LED beneath the #2 will light to indicate the remote control is ready for pairing.
7. Reapply power to the controller unit. NOTE: this step must be completed within 10 seconds of the previous step.
8. The controller unit's LED display will flash **Pa id**.
9. The remote control will confirm the download is complete by flashing the middle LED five times.
10. Disconnect power to the controller unit.
11. Remove the jumper from the pairing position and install it in the jumper rest position.
12. Reinstall the controller unit's front cover.
13. Reinstall the spreader's right side cover.
14. Reconnect power to the controller unit.

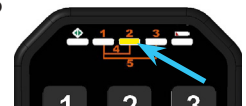

SERVICE

Replacing Remote Control Batteries

CAUTION

Install batteries correctly, observing the polarity signs (+, -) to avoid battery leakage.

Non-rechargeable batteries are not to be recharged.

Do not mix old and new batteries.

Do not mix batteries of different types: alkaline, carbon-zinc, Ni-Cad, Ni-MH, or lithium.

Remove batteries from the remote control when the unit will not be used for an extended period of time.

Always remove exhausted batteries from the remote control.

Dispose of batteries properly by taking them to local collection points.

1. Remove the screw that fastens the belt clip (A) to the back of the remote control.



2. Remove the 3) screws that fasten the battery compartment cover (B) to the remote control.
3. Remove the batteries from the remote control.
4. Clean the battery compartment area of all dust and dirt to ensure no water can enter the unit.
5. Install three new 1.5 volt AAA size batteries with correct polarity, as shown inside the battery compartment.
6. Reinstall the battery compartment cover.
7. Reinstall the belt clip onto the back of the remote control.

Storage

Preparing the Spreader for Storage

1. Clean and wash the spreader.
2. Allow the spreader to dry, then apply a rust preventative coating to the chain drive sprockets.
3. Remove any rust from the hitch mount(s), and paint any bare metal hitch mount surfaces.
4. Inspect for loose or missing hardware, damaged components, or signs of wear.
5. Inspect motor for oil leaks.
6. Inspect safety decals. Replace any safety decals that are faded, illegible, or missing.
7. Apply grease to all grease points.
8. Apply chain oil to the drive chain.
9. Wipe off all excess grease and oil.
10. Place the spreader on a skid or wood blocks for storage. Store the remote control at a safe location where it will not get damaged or lost.

Removing the Spreader from Storage

1. Clean the drop spreader to remove any accumulated dust or debris.
2. Inspect the drop spreader as instructed in the daily inspection section of this manual.
3. Test the drop spreader to ensure all components are working properly.

SERVICE

Maintenance Schedule

Maintenance Schedule	# of Locations	# of Pumps	AS NEEDED	Daily	At 50 Hours	At 100 Hours	At 150 Hours	At 200 Hours	At 250 Hours	At 300 Hours	At 350 Hours	At 400 Hours	At 450 Hours	At 500 Hours	At 550 Hours	At 600 Hours	At 650 Hours	At 700 Hours	At 750 Hours	At 800 Hours	At 850 Hours	At 900 Hours	At 950 Hours	At 1000 Hours	Yearly	
																										Grease & Lubrication: See Lubrication Section
Rotor Bearings	2	1			✓	✓	✓	✓	✓	✓	✓	✓	✓	✓	✓	✓	✓	✓	✓	✓	✓	✓	✓	✓	✓	✓
Roller Seal Bearing	2	1			✓	✓	✓	✓	✓	✓	✓	✓	✓	✓	✓	✓	✓	✓	✓	✓	✓	✓	✓	✓	✓	✓
Oil Drive Chain					✓	✓	✓	✓	✓	✓	✓	✓	✓	✓	✓	✓	✓	✓	✓	✓	✓	✓	✓	✓	✓	✓
Change Motor Oil														✓											✓	
Inspection																										
Inspect for Loose, Missing, or Worn Components.			✓																							
Inspect Motor For Oil Leaks			✓																							
Check Safety Decals			✓																							
Inspect Drive Chain Tension				✓	✓	✓	✓	✓	✓	✓	✓	✓	✓	✓	✓	✓	✓	✓	✓	✓	✓	✓	✓	✓	✓	✓

Maintenance Checklist

Maintenance Checklist	# of Locations	# of Pumps	AS NEEDED	Daily	At 50 Hours	At 100 Hours	At 150 Hours	At 200 Hours	At 250 Hours	At 300 Hours	At 350 Hours	At 400 Hours	At 450 Hours	At 500 Hours	At 550 Hours	At 600 Hours	At 650 Hours	At 700 Hours	At 750 Hours	At 800 Hours	At 850 Hours	At 900 Hours	At 950 Hours	At 1000 Hours	Yearly	
																										Grease & Lubrication: See Lubrication Section
Rotor Bearings	2	1																								
Roller Seal Bearing	2	1																								
Oil Drive Chain																										
Change Motor Oil																										
Inspection																										
Inspect for Loose, Missing, or Worn Components.																										
Inspect Motor For Oil Leaks																										
Check Safety Decals																										
Inspect Drive Chain Tension																										

SPECIFICATIONS

Dimensions

Overall Height	16 inches (41 cm)
Overall Length	22 inches (56 cm)
Overall Width47 inches (119 cm)
Weight	160 pounds (73 kg)
Drop Width.	40 inches (102 cm)
Material Capacity (Volume)	2.5 ft ³ (.071 m ³)
Material Capacity (Weight)	200 pounds (91 kg)

Technical Information

System

Voltage.	12 volt DC
Amperage	up to 12 Amps
Temperature Range	-20° F (-29° C) to 50° F (10° C)

Controller

Frequency2.4 GHz (Frequency Jumping)
IP Rating.	IP65

Remote Control Transmitter

BatteriesAAA (3)
IP Rating.	IP67

Motor

Type	Permanent Magnet
Gear Oil	Ventrac HydroTorq XL

Features

- Stainless steel construction
- Weatherproof hopper cover
- Innovative agitation system
- Precision drop rate control for increased salt savings and consistent drop patterns
- Compression roller system
- Easy flow adjustments
- Material safety grate
- Low maintenance design
- Wireless remote control
- 12 volt electric drive/transmission
- Universal mounting options
- Ability to spread coarse materials such as bulk salt and sand/salt mixtures, as well as free flowing material such as pelletized material and calcium flakes.

PARTS

ILLUSTRATED DRAWING Main Frame

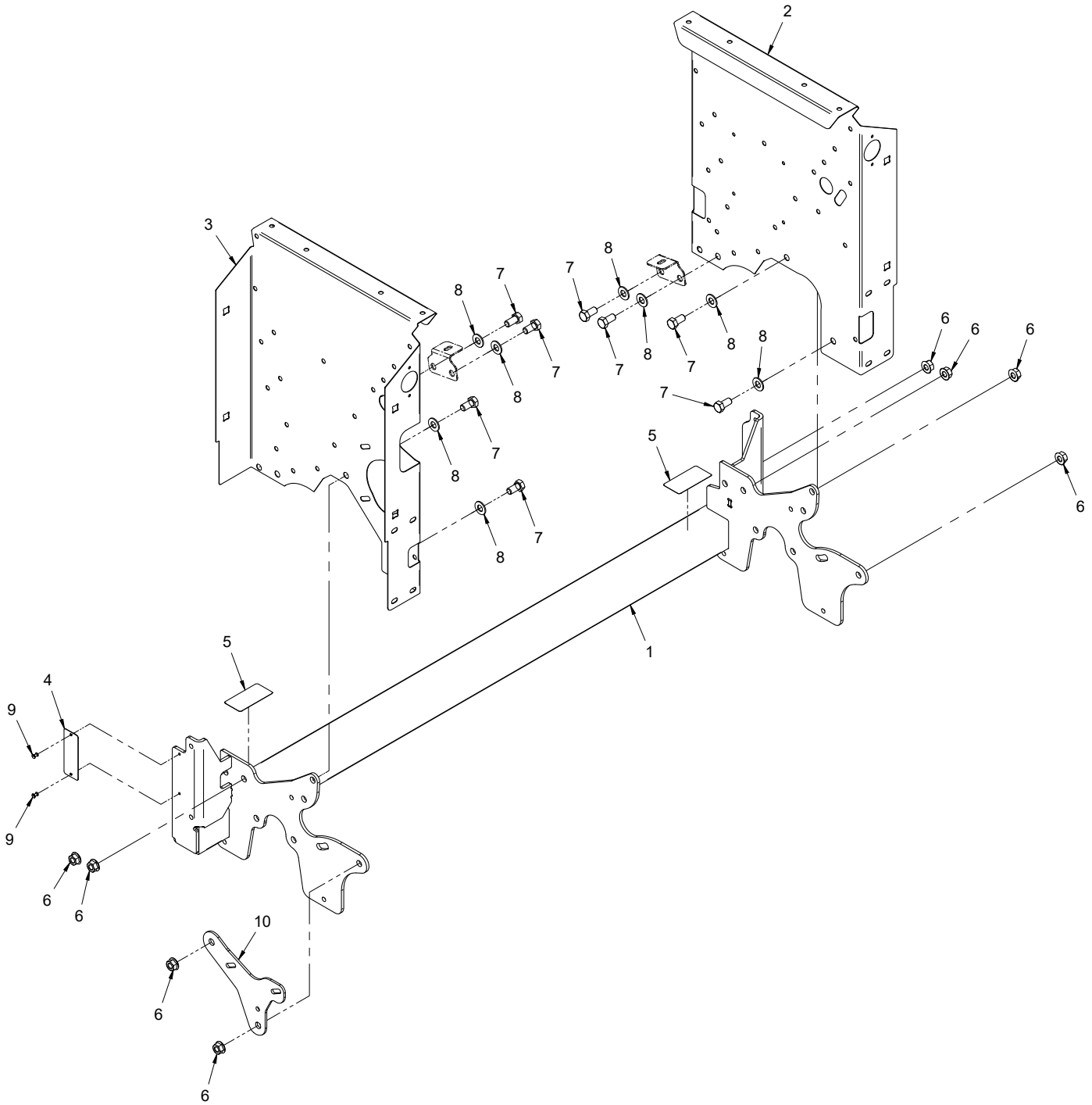

PARTS

Main Frame

REF.	PART NO.	DESCRIPTION	QTY.
1	62.1416	.FRAME, MAIN SA SPREADER	1
2	60.1232	.PANEL, BIN RIGHT	1
3	60.1231	.PANEL, BIN LEFT	1
4	N/A	.PLATE, VENTRAC SERIAL NUMBER	1
5	00.0365	.DECAL, WARNING MOVING PARTS	2
6	99.SF06-3	.NUT, SRF 3/8-16 USS STAINLESS	8
7	90.0606-3	.BOLT, 3/8-16 USS X 3/4SS	8
8	95.06-3	.WASHER, FLAT 3/8 SAE SS	8
9	04.0029	.RIVET, POP 1/8" X 1/4"	2
10	64.1943	.PLATE, MOTOR END SUPPORT (Serial # 1812-)	1

PARTS

ILLUSTRATED DRAWING Rear & Side Bumpers

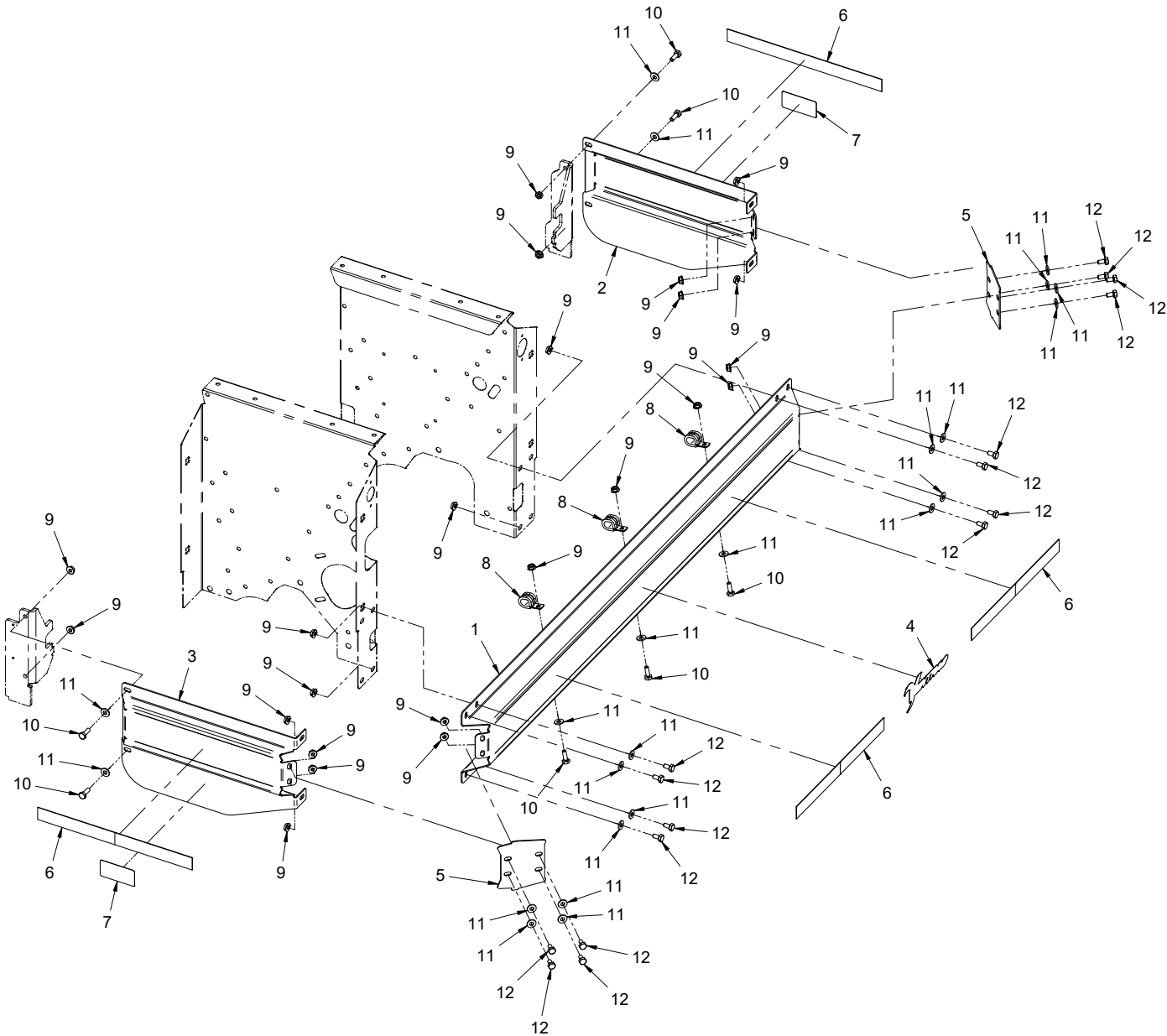

PARTS

Rear & Side Bumpers

REF.	PART NO.	DESCRIPTION	QTY.
1	62.1417	.BUMPER, REAR	1
2	62.1418	.BUMPER, RIGHT	1
3	62.1419	.BUMPER, LEFT	1
4	00.0382	.DECAL, VENTRAC	1
5	64.1843	.PLATE, BUMPER CORNER	2
6	56.0063-12IN	.TAPE, CONSPICUITY (REFLECTIVE) X 12"	4
7	00.0365	.DECAL, WARNING MOVING PARTS	2
8	11.0076	.CLAMP, CUSHIONED 1/2" SS	3
9	99.SF04-3	.NUT, SRF 1/4-20 USS STAINLESS	23
10	90.0406-3	.BOLT, 1/4-20 USS X 3/4 SS	7
11	95.04-3	.WASHER, FLAT 1/4 SAE SS	23
12	90.0404-3	.BOLT, 1/4-20 USS X 1/2 SS	16

PARTS

ILLUSTRATED DRAWING Hopper Panels

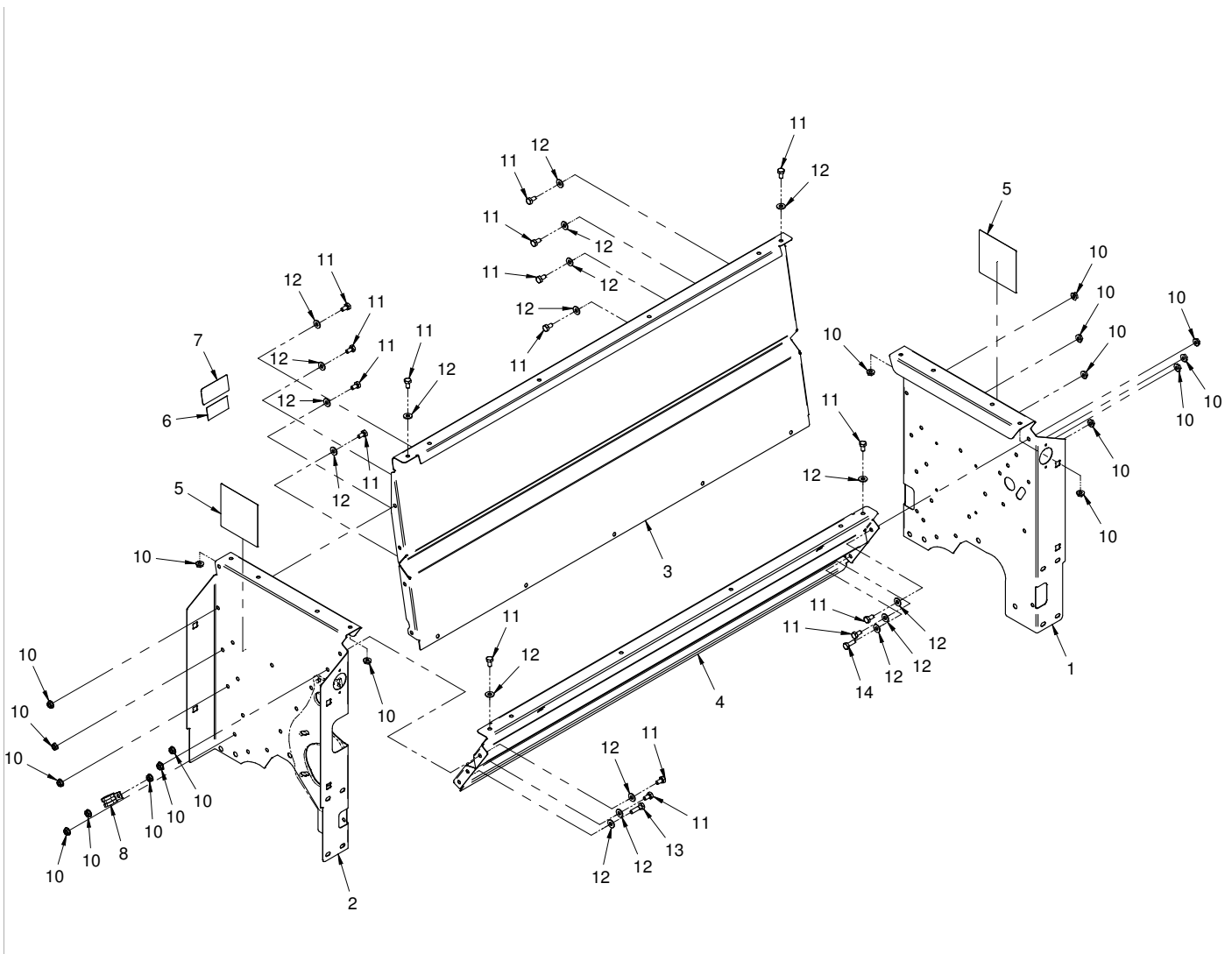

PARTS

Hopper Panels

REF.	PART NO.	DESCRIPTION	QTY.
1	60.1232	.PANEL, BIN RIGHT	1
2	60.1231	.PANEL, BIN LEFT	1
3	60.1229	.PANEL, BIN FRONT	1
4	60.1230	.PANEL, BIN REAR	1
5	00.0062	.DECAL, DANGER SHIELD MISSING	2
6	00.0100	.DECAL, MADE IN USA	1
7	00.0363	.DECAL, WARNING READ OWNERS MAN	1
8	11.0076	.CLAMP, CUSHIONED 1/2" SS	1
10	99.SF04-3	.NUT, SRF 1/4-20 USS STAINLESS	19
11	90.0404-3	.BOLT, 1/4-20 USS X 1/2 SS	16
12	95.04-3	.WASHER, FLAT 1/4 SAE SS	18
13	90.0408-3	.BOLT, 1/4-20 USS X 1 SS	1
14	90.0406-3	.BOLT, 1/4-20 USS X 3/4 SS	1

PARTS

ILLUSTRATED DRAWING Spreader Hanger, Hopper Screen, & Top Cover

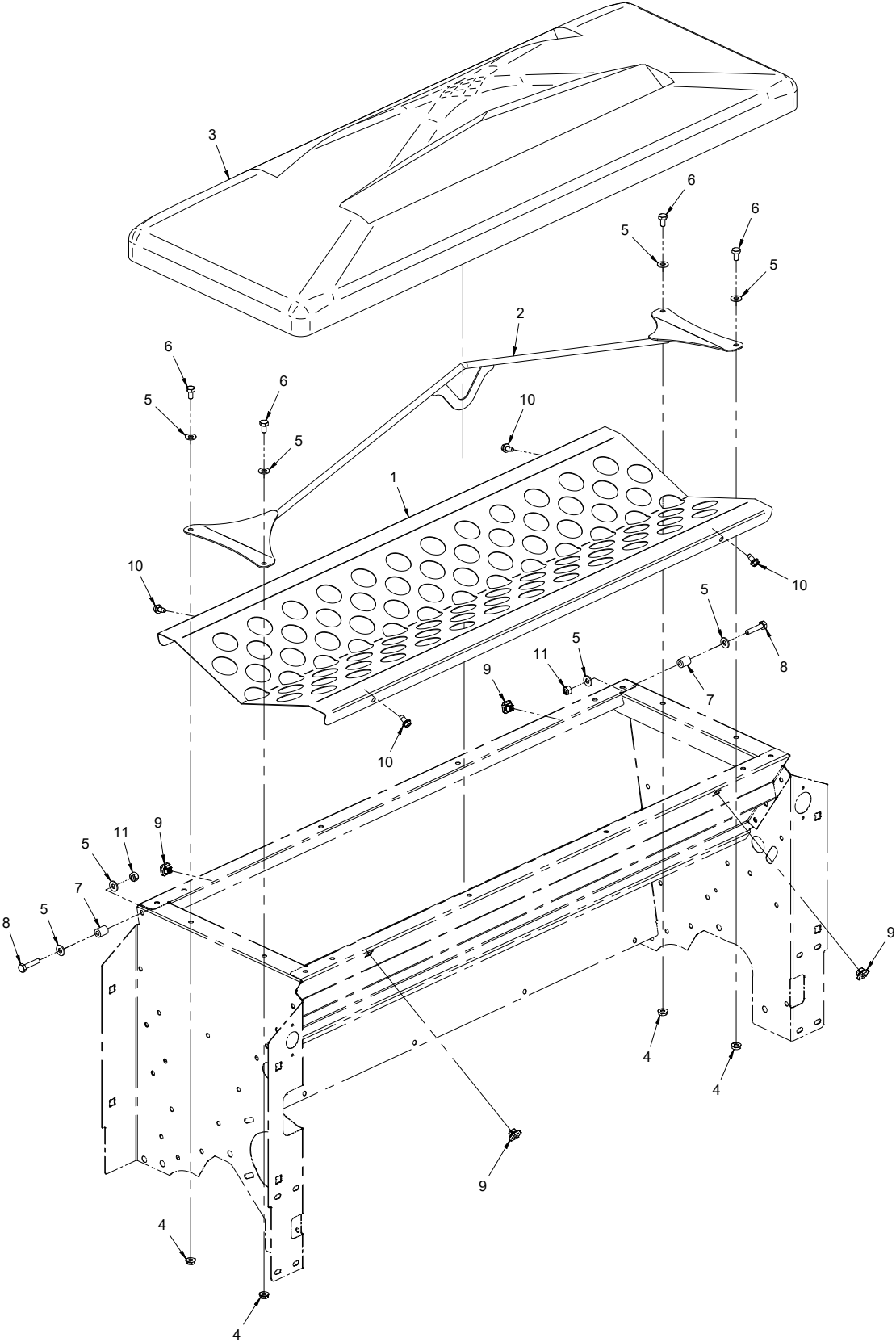

PARTS

Spreader Hanger, Hopper Screen, & Top Cover

REF.	PART NO.	DESCRIPTION	QTY.
1	64.1836	.SCREEN, DEBRIS - TOP	1
2	64.1842	.HANGER, SPREADER BAR	1
3	44.0338	.COVER, SA SPREADER- TOP	1
4	99.SF04-3	.NUT, SF 1/4-20 USS STAINLESS	4
5	95.04-3	.WASHER, FLAT 1/4 SAE SS	8
6	90.0404-3	.BOLT, 1/4-20 USS X 1/2 SS	4
7	05.0142	.SPACER, 1/4 ID X 1/2 OD X 5/8L	2
8	90.0410-3	.BOLT, 1/4-20 USS X 1-1/4 SS	2
9	99.E0116	.NUT, GROMMET 1/4"	4
10	99.K0136	.BOLT, 1/4-20 X 1/2 THD FORM SS	4
11	99.A04N-3	.LOCKNUT, NYLON 1/4-20 USS SS	2

PARTS

ILLUSTRATED DRAWING Gate Panel & Guides

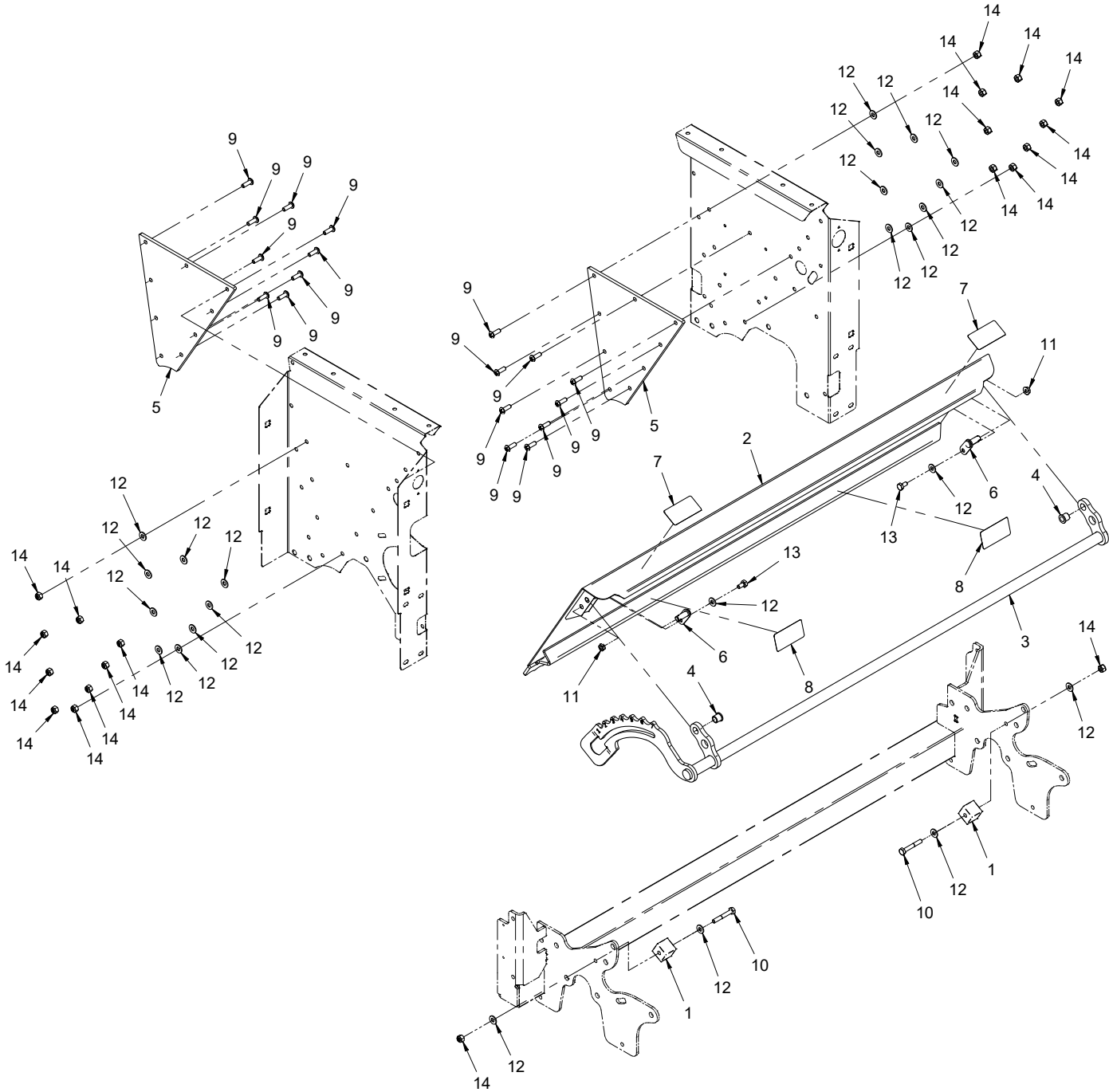

PARTS

Gate Panel & Guides

REF.	PART NO.	DESCRIPTION	QTY.
1	42.0573	.GUIDE, GATE BOTTOM	2
2	60.1237	.PANEL, GATE SA SPREADER	1
3	64.1841	.ROCKER, GATE CONTROL	1
4	85.B0068	.BUSHING, 3/8 X 1/2 OD X 1/2 LG	2
5	44.0337	.PANEL, GATE GUIDE END	2
6	64.1845	.PIN, GATE CONTROL ROCKER	2
7	00.0364	.DECAL, WARNING PINCH POINT	2
8	00.0365	.DECAL, WARNING MOVING PARTS	2
9	99.0406-3	.BOLT, 1/4-20 X 3/4 BSCS SS	18
10	90.0414-3	.BOLT, 1/4-20 USS X 1-3/4" SS	2
11	99.SF04-3	.NUT, SF 1/4-20 USS STAINLESS	2
12	95.04-3	.WASHER, FLAT 1/4 SAE SS	24
13	90.0404-3	.BOLT, 1/4-20 USS X 1/2 SS	2
14	99.A04N-3	.LOCKNUT, NYLON 1/4-20 USS SS	20

PARTS

ILLUSTRATED DRAWING Gate Control Rocker

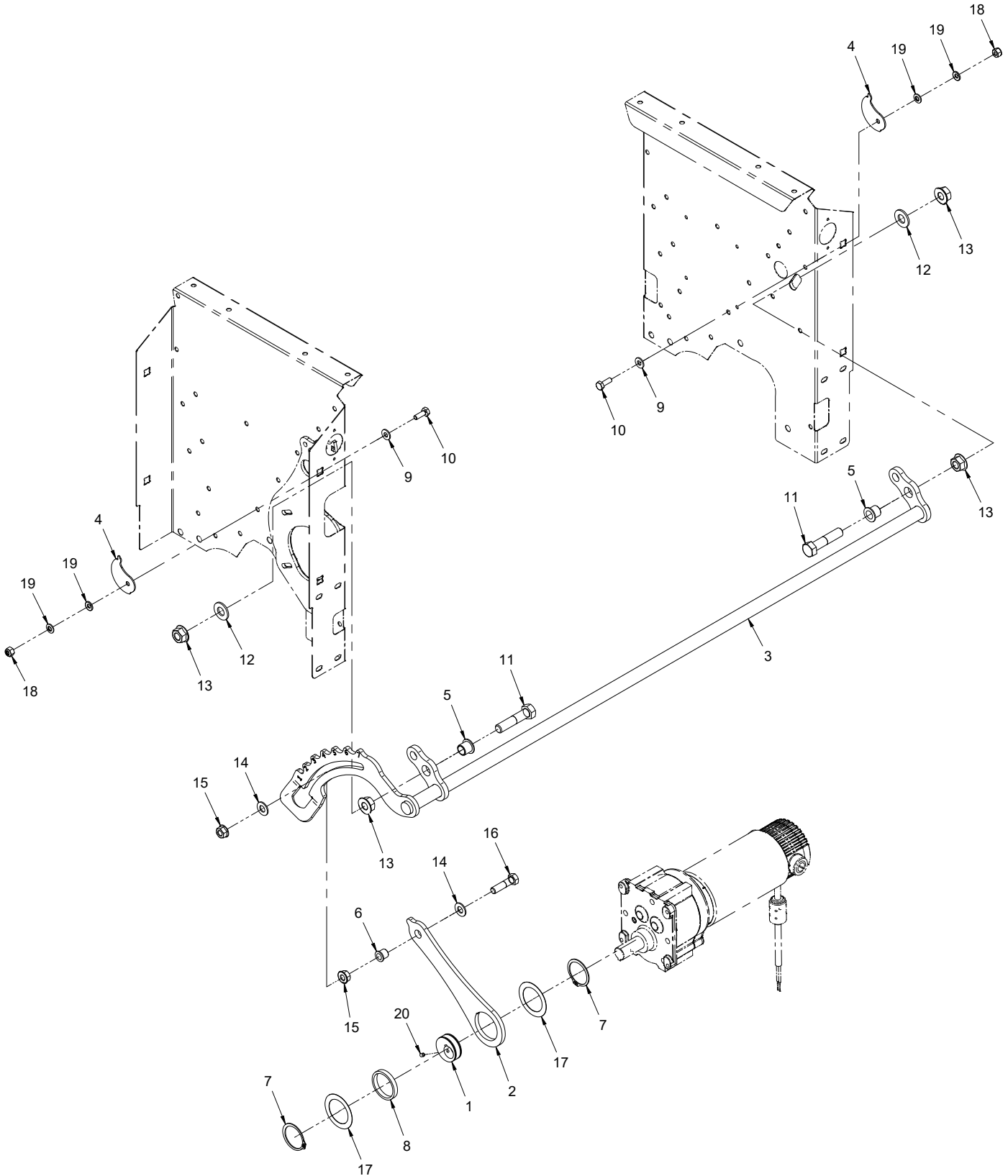

PARTS

Gate Control Rocker

REF.	PART NO.	DESCRIPTION	QTY.
1	42.0568	.CAM, DRIVE	1
2	42.0571	.LINK, SA SPREADER GATE	1
3	64.1841	.ROCKER, GATE CONTROL	1
4	64.1840	.PLATE, GATE INDICATOR	2
5	85.B0027	.BUSHING, 1/2 ID X 5/8 OD X 5/8	2
6	85.B0068	.BUSHING, 3/8 X 1/2 OD X 1/2 LG	1
7	04.0034	.SNAP RING, EXT 1.387 X .05 THK	2
8	85.B0092	.BUSHING, BRONZE SLEEVE	1
9	95.04-3	.WASHER, FLAT 1/4 SAE SS	2
10	90.0406-3	.BOLT, 1/4-20 USS X 3/4 SS	2
11	90.0818-3	.BOLT, 1/2-13 USS X 2-1/4 SS	2
12	95.08-3	.WASHER, FLAT 1/2 SAE SS	2
13	99.SF08-3	.NUT, SRF 1/2-13 USS STAINLESS	4
14	95.06-3	.WASHER, FLAT 3/8 SAE SS	2
15	99.SF06-3	.NUT, SRF 3/8-16 USS STAINLESS	2
16	90.0612-3	.BOLT, 3/8-16 USS X 1-1/2 SS	1
17	99.B0112	.SHIM, 1.5ID X 2.13 OD .020T SS	2
18	99.A04N-3	.LOCKNUT, NYLON 1/4-20 USS SS	2
19	99.M0036	.WASHER, M6 SPRING LOCK 316 SS	4
20	85.SS26	.SET SCREW, 10-32 X 1/4 SS	1

PARTS

ILLUSTRATED DRAWING Motor & Rotor

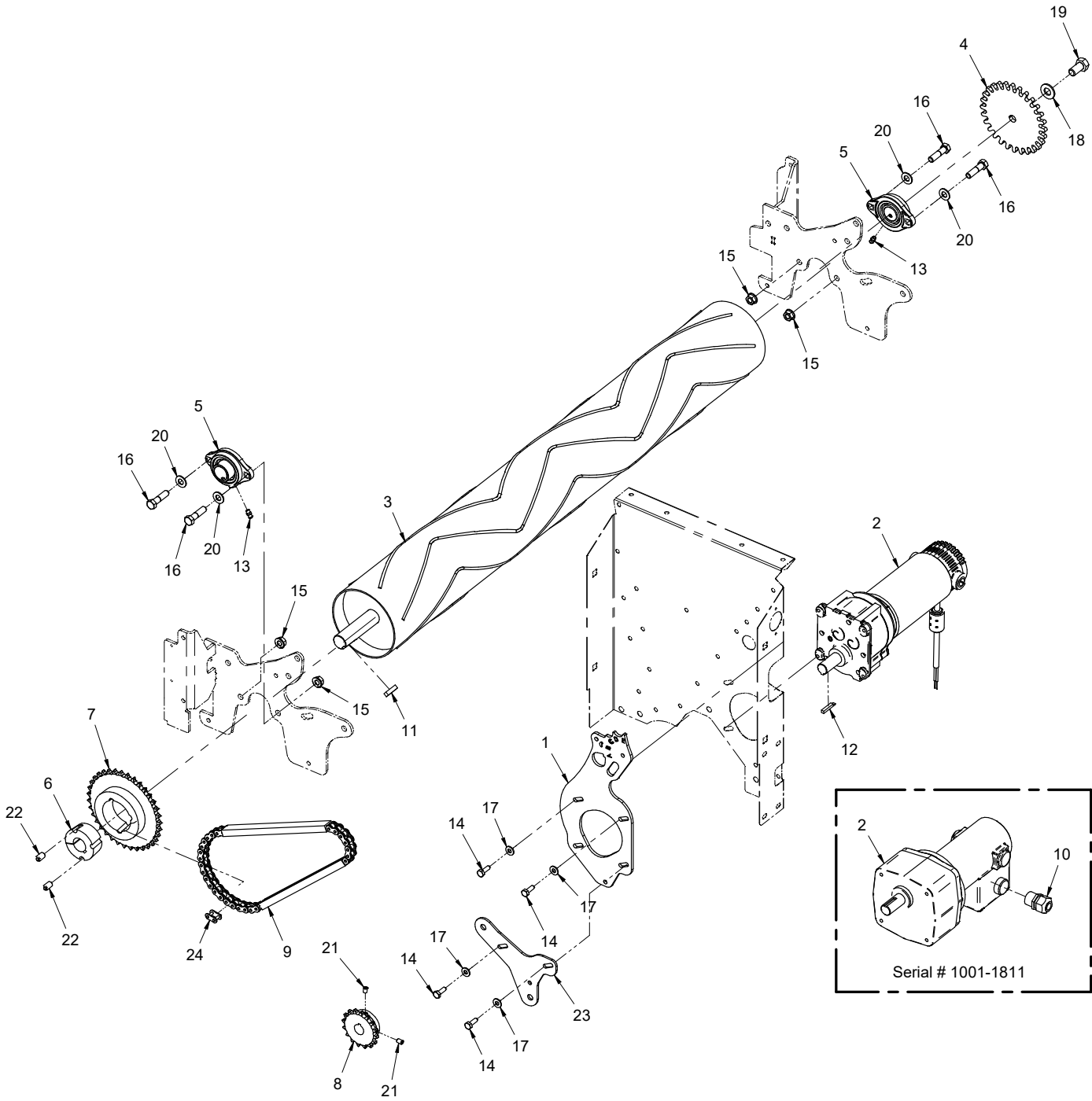

PARTS

Motor & Rotor

REF.	PART NO.	DESCRIPTION	QTY.
1	64.1839	.STIFFENER, END PANEL LEFT	1
2	37.0062	.MOTOR, ELECTRIC GEAR 1/8HP (Serial # 1001-1811)	1
2	37.0064	.MOTOR, ELEC GEAR 1/6 HP 12 RPM (Serial # 1812-)	1
3	80.0381	.ROTOR, SA SPREADER	1
4	87.0237	.GEAR, SA SPREADER ROTOR	1
5	55.FB16016-3	.BEARING, FLANGE BLOCK 1" ZP	2
6	83.161016	.BUSHING, 1610 X 1" TAPERD LOCK	1
7	83.40TB35	.SPROCKET, #40 35-T TAPER BORE	1
8	83.H4016	.SPROCKET, #40 16-T 3/4" BORE	1
9	81.0155	.CHAIN, ROLLER #40 X 28-1/2"	1
10	47.0364	.FITTING, CORD GRIP 1/2 NPT (Serial # 1001-1811)	1
11	85.K0408-3	.KEY, 1/4 X 1 316SS	1
12	85.K0001	.KEY, SA250 MOTOR	1
13	29.GF0001	.GREASE FTG, 1/4 SAE ST	2
14	91.0406-3	.BOLT, 1/4-28 SAE X 3/4 SS	4
15	99.SF06-3	.NUT, SRF 3/8-16 USS STAINLESS	4
16	90.0612-3	.BOLT, 3/8-16 USS X 1-1/2 SS	4
17	95.04-3	.WASHER, FLAT 1/4 SAE SS	4
18	95.08-3	.WASHER, FLAT 1/2 SAE SS	1
19	90.0808-3	.BOLT, 1/2-13 USS X 1 SS	1
20	95.06-3	.WASHER, FLAT 3/8 SAE SS	4
21	85.SS24	.SET SCREW, 1/4-20 X 3/8 SS	2
22	85.SS27	.SET SCREW, 3/8-16 X 5/8 SS	2
23	64.1943	.PLATE, MOTOR END SUPPORT (Serial # 1812-)	1
24	81.0056-1	.LINK, CONN #40 SS	1

PARTS

ILLUSTRATED DRAWING Front Bin Seal & Rear Roller Seal

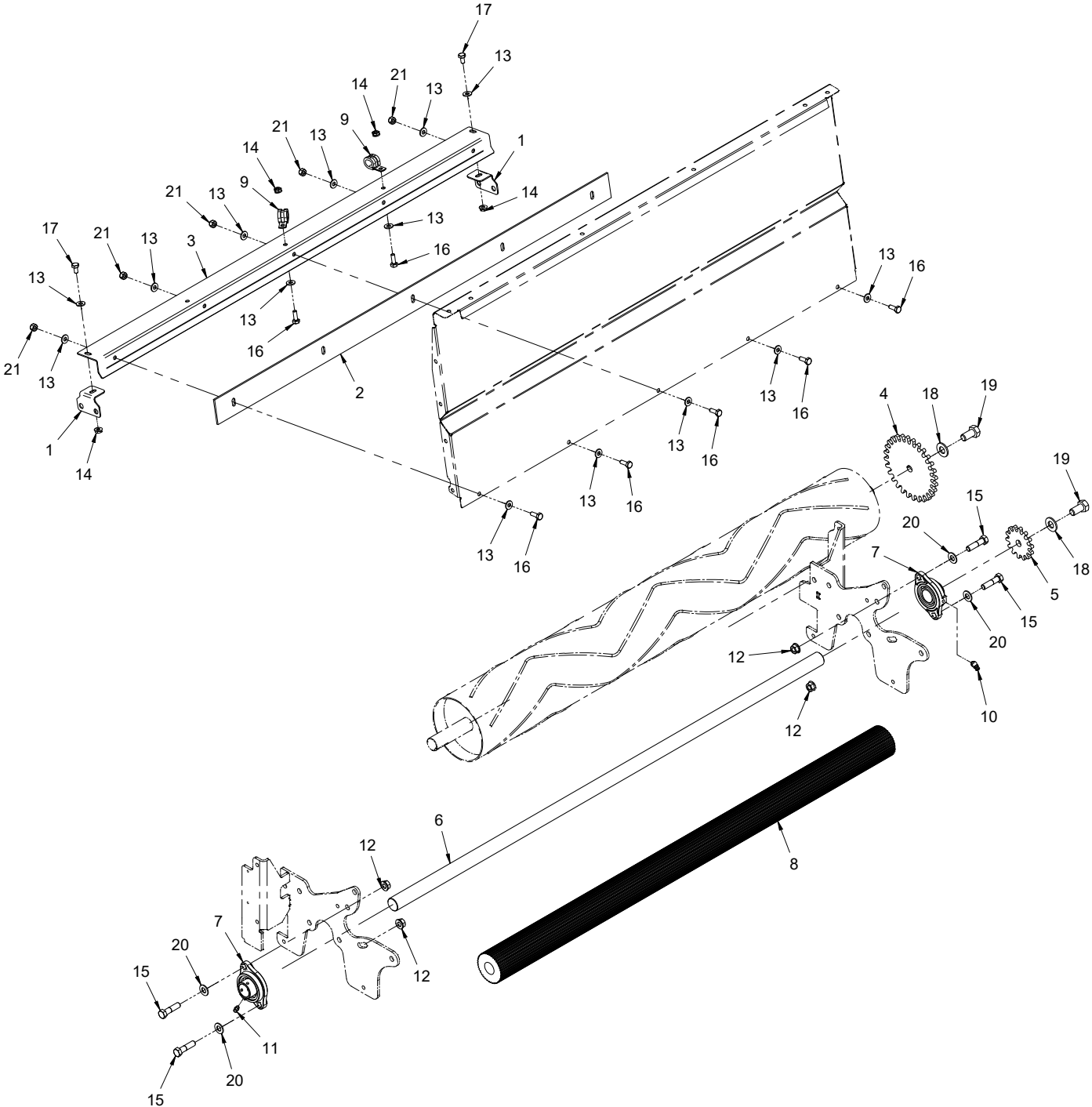

PARTS

Front Bin Seal & Rear Roller Seal

REF.	PART NO.	DESCRIPTION	QTY.
1	64.1837	.BRACKET, BELTING CLAMP MOUNT	2
2	44.0335	.SEAL, BIN FRONT BELTING	1
3	64.1820	.CLAMP, BIN FRONT BELTING SEAL	1
4	87.0237	.GEAR, SA SPREADER ROTOR	1
5	87.0238	.GEAR, SA SPREADER SEAL	1
6	80.0382	.SHAFT, TUBE SEAL	1
7	55.FB16016-3	.BEARING, FLANGE BLOCK 1" ZP	2
8	44.0336	.SEAL, BIN REAR TUBE	1
9	11.0076	.CLAMP, CUSHIONED 1/2" SS	2
10	29.GF0003	.GREASE FTG, 1/4 SAE 45	1
11	29.GF0001	.GREASE FTG, 1/4 SAE ST	1
12	99.SF06-3	.NUT, SRF 3/8-16 USS STAINLESS	4
13	95.04-3	.WASHER, FLAT 1/4 SAE SS	14
15	90.0612-3	.BOLT, 3/8-16 USS X 1-1/2 SS	4
16	90.0406-3	.BOLT, 1/4-20 USS X 3/4 SS	7
14	99.SF04-3	.NUT, SF 1/4-20 USS STAINLESS	4
17	90.0404-3	.BOLT, 1/4-20 USS X 1/2 SS	2
18	95.08-3	.WASHER, FLAT 1/2 SAE SS	2
19	90.0808-3	.BOLT, 1/2-13 USS X 1 SS	2
20	95.06-3	.WASHER, FLAT 3/8 SAE SS	4
21	99.A04N-3	.LOCKNUT, NYLON 1/4-20 USS SS	5

PARTS

ILLUSTRATED DRAWING End Panel Stiffeners, Covers, & Clamps

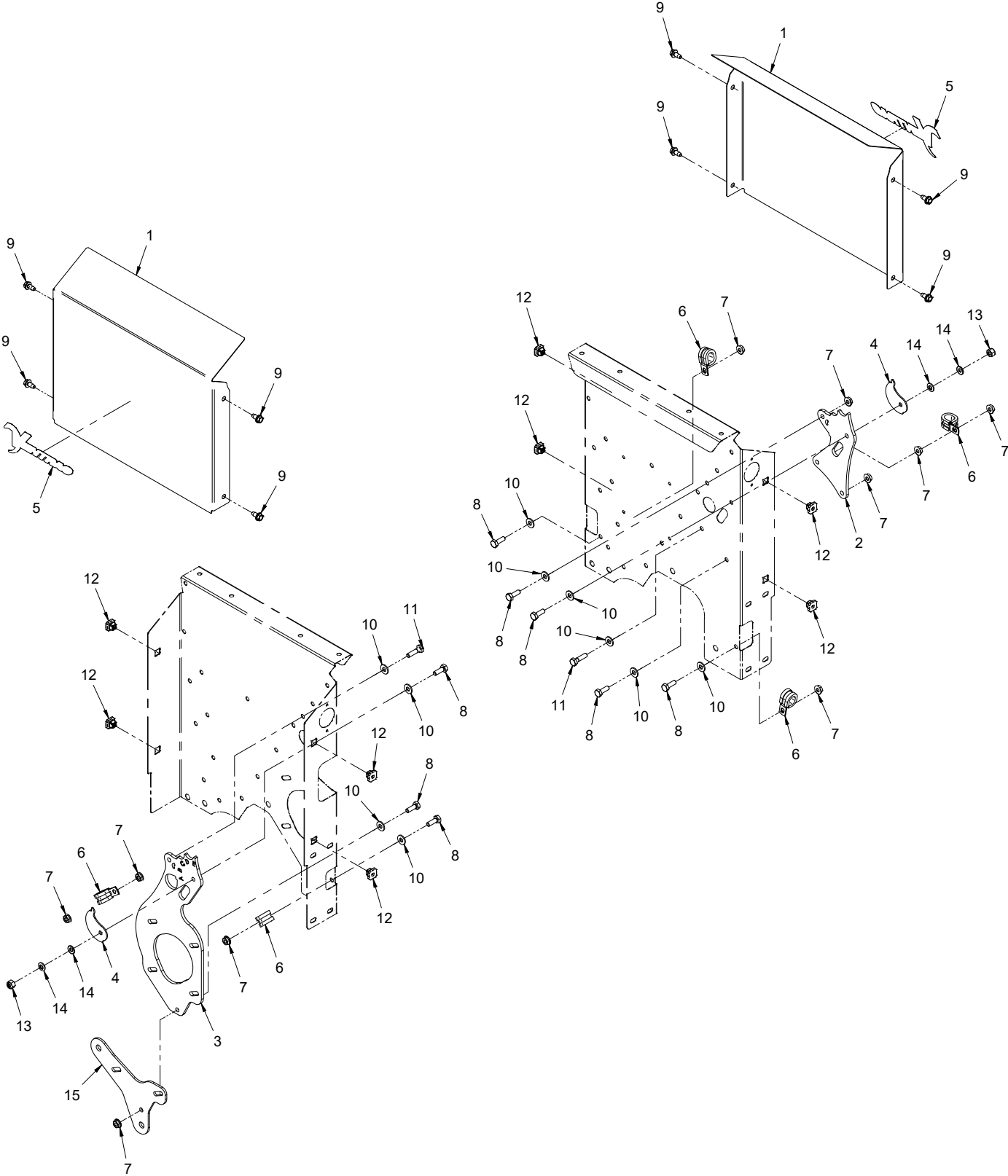

PARTS

End Panel Stiffeners, Covers, & Clamps

REF.	PART NO.	DESCRIPTION	QTY.
1	60.1238	.COVER, SA SPREADER END.	2
2	64.1838	.STIFFENER, END PANEL RIGHT.	1
3	64.1839	.STIFFENER, END PANEL LEFT	1
4	64.1840	.PLATE, GATE INDICATOR	2
5	00.0382	.DECAL, VENTRAC.	2
6	11.0076	.CLAMP, CUSHIONED 1/2" SS.	5
7	99.SF04-3	.NUT, SRF 1/4-20 USS STAINLESS.	10
8	90.0406-3	.BOLT, 1/4-20 USS X 3/4 SS	8
9	99.K0136	.BOLT, 1/4-20 X 1/2 THD FORM SS	8
10	95.04-3	.WASHER, FLAT 1/4 SAE SS	10
11	90.0408-3	.BOLT, 1/4-20 USS X 1 SS.	2
12	99.E0116	.NUT, GROMMET 1/4"	8
13	99.A04N-3	.LOCKNUT, NYLON 1/4-20 USS SS.	2
14	99.M0036	.WASHER, M6 SPRING LOCK 316 SS	4
15	64.1943	.PLATE, MOTOR END SUPPORT (Serial # 1812-)	1

PARTS

ILLUSTRATED DRAWING Controller & Lights

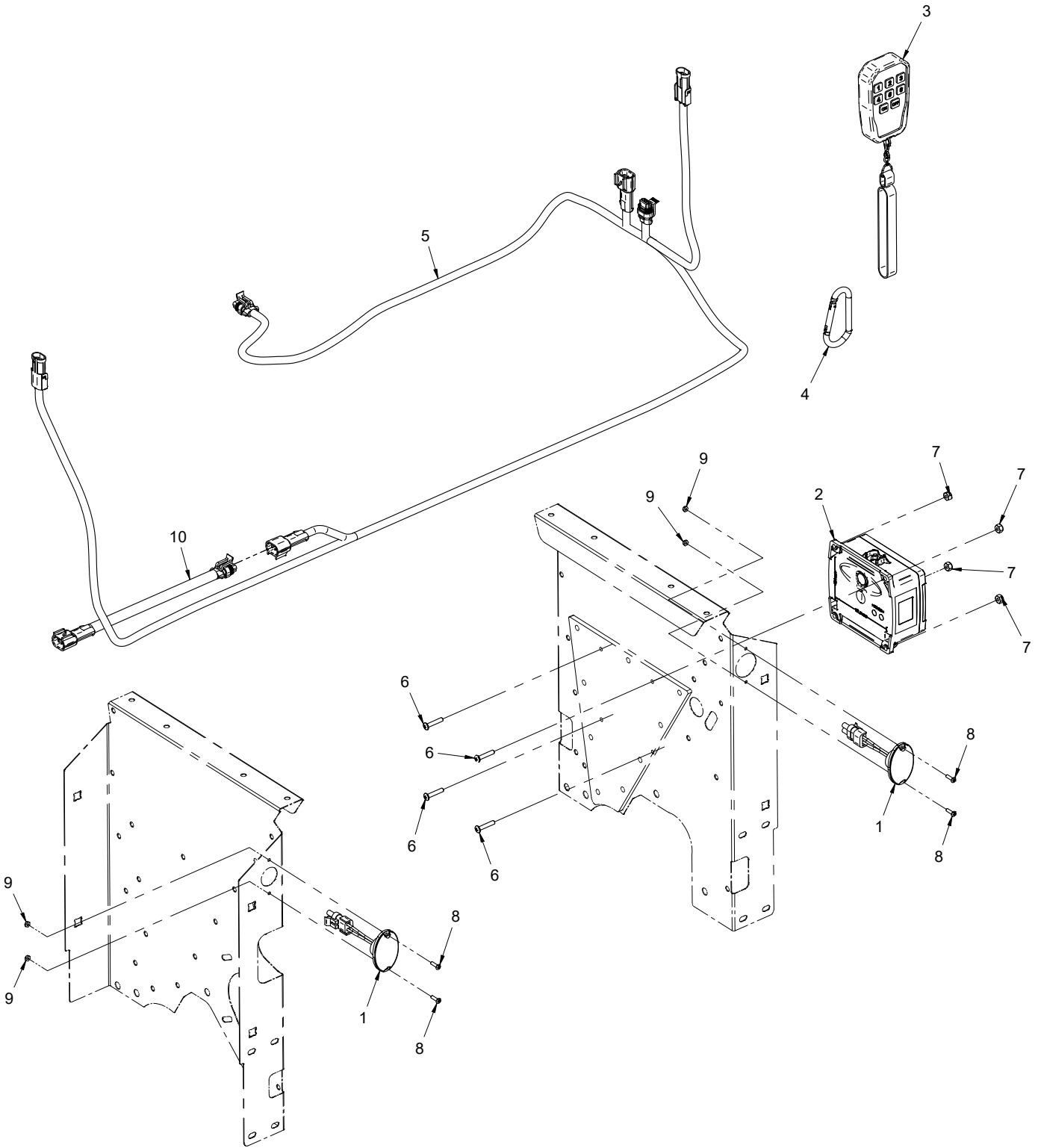

PARTS

Controller & Lights

REF.	PART NO.	DESCRIPTION	QTY.
1	33.0061	LIGHT, MARKER RED OVAL	2
2	35.0141	RECEIVER, WIRELESS	1
3	35.0142	TRANSMITTER, WIRELESS	1
4	47.0365	CARABINER, 1/4" 316SS	1
5	32.0145	HARNESS, WIRE SA MAIN	1
6	99.K0139	MACHINE SCREW, #10-32 X 1 SS	4
7	99.A1032N	LOCKNUT, NYLON 10-32 STAINLESS	4
8	99.K0138	MACHINE SCREW, #6-32 X 1/2 SS	4
9	99.E0118	LOCKNUT, NYLON #6-32 SS	4
10	32.0164	HARNESS, MOTOR DIODE	1

PARTS

ILLUSTRATED DRAWING 70.8149 Hopper Extension Kit

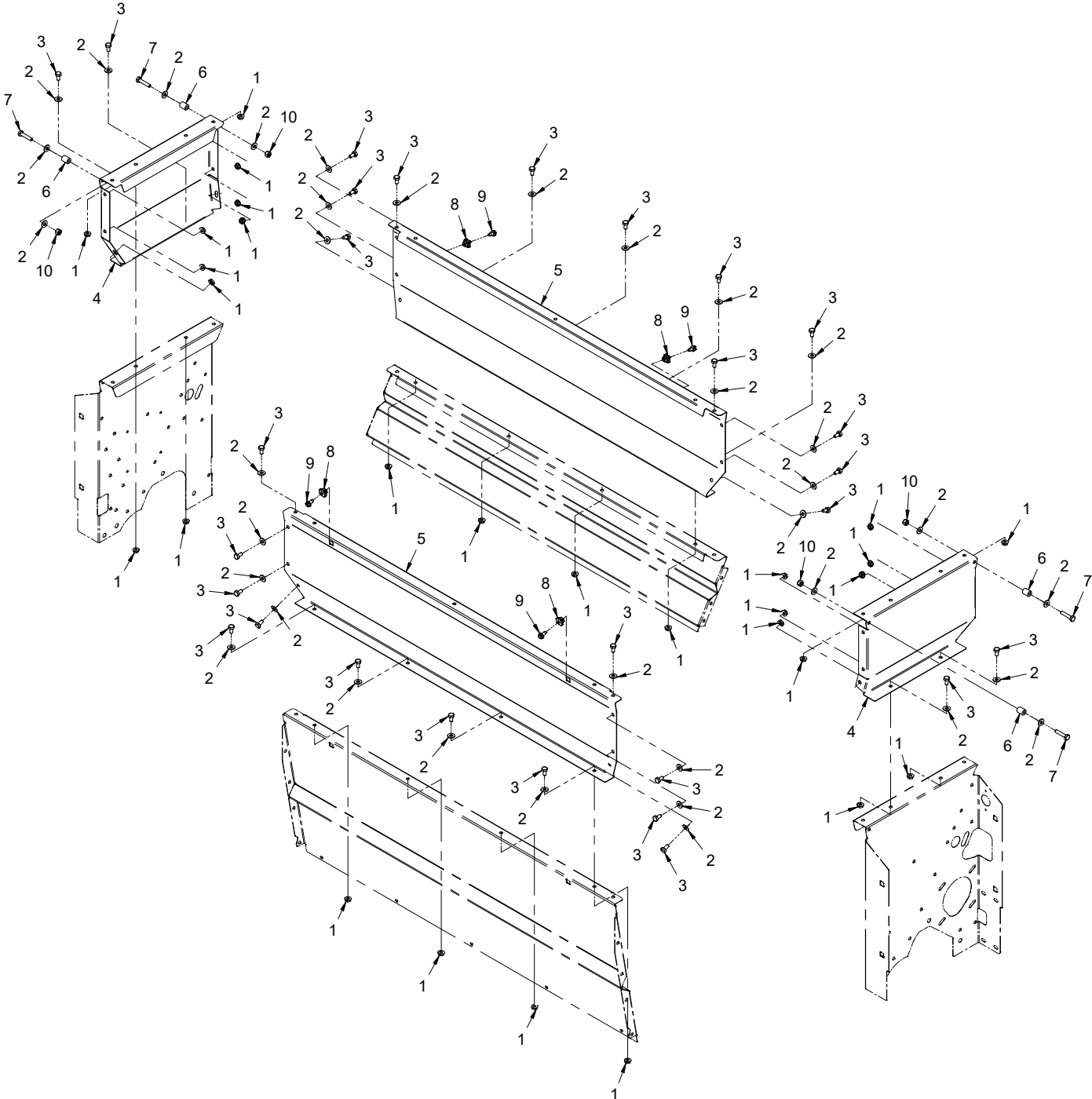

PARTS

70.8149 Hopper Extension Kit

REF.	PART NO.	DESCRIPTION	QTY.
1	99.SF04-3	.NUT, SF 1/4-20 USS STAINLESS	28
2	95.04-3	.WASHER, FLAT 1/4 SAE SS	36
3	90.0404-3	.BOLT, 1/4-20 USS X 1/2 SS	28
4	60.1234	.PANEL, BIN EXT LEFT/RIGHT	2
5	60.1233	.PANEL, BIN EXTENSION FRNT/REAR	2
6	05.0142	.SPACER, 1/4 ID X 1/2 OD X 5/8L	4
7	90.0410-3	.BOLT, 1/4-20 USS X 1-1/4 SS	4
8	99.E0116	.NUT, GROMMET 1/4"	4
9	99.K0136	.BOLT, 1/4-20 X 1/2 THD FORM SS	4
10	99.A04N-3	.LOCKNUT, NYLON 1/4-20 USS SS	4

PARTS

ILLUSTRATED DRAWING 70.8150 High Speed Sprocket Kit

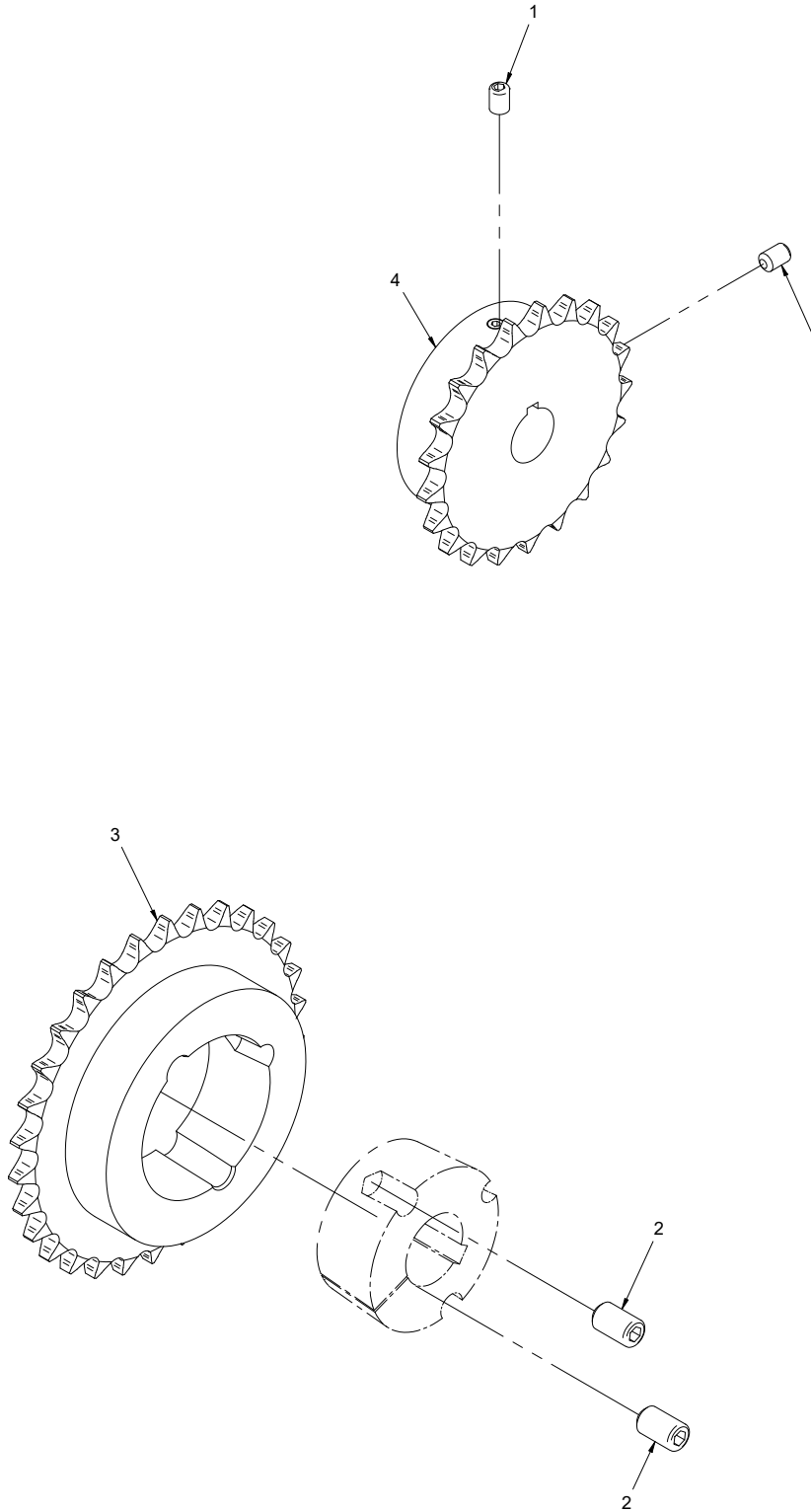

PARTS

70.8150 High Speed Sprocket Kit

REF.	PART NO.	DESCRIPTION	QTY.
1	85.SS24	.SET SCREW, 1/4-20 X 3/8 SS	2
2	85.SS27	.SET SCREW, 3/8-16 X 5/8 SS	2
3	83.40TB30	.SPROCKET, #40 30-T TAPER BORE	1
4	83.H4021	.SPROCKET, #40 21-T 3/4" BORE	1

PARTS

ILLUSTRATED DRAWING 70.8186 Slow Speed Sprocket Kit

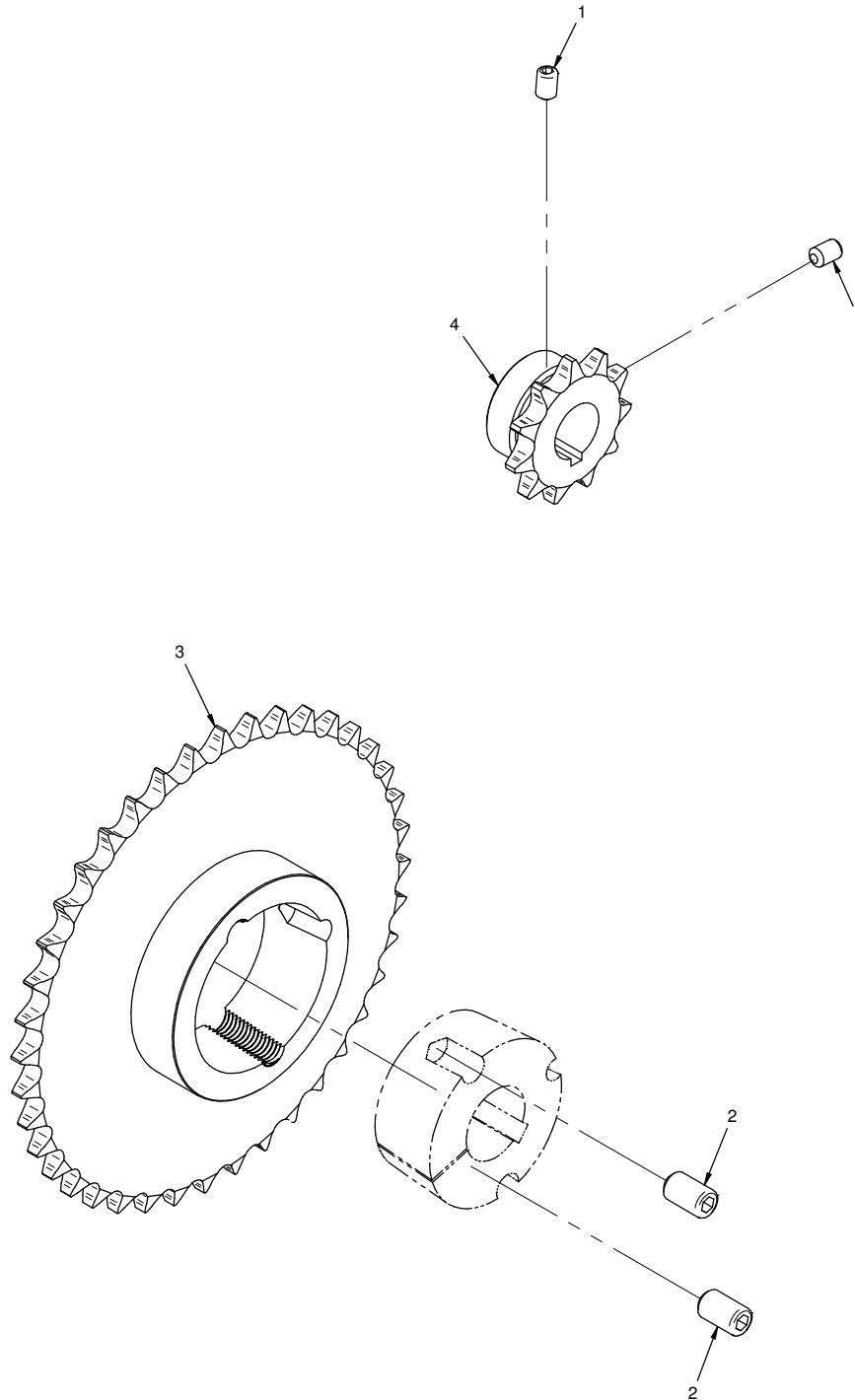

PARTS

70.8186 Slow Speed Sprocket Kit

REF.	PART NO.	DESCRIPTION	QTY.
1	85.SS24	.SET SCREW, 1/4-20 X 3/8 SS	2
2	85.SS27	.SET SCREW, 3/8-16 X 5/8 SS	2
3	83.40TB40	.SPROCKET, #40 40-T TAPER BORE	1
4	83.H401112	.SPROCKET, #40 11-T HRD 3/4"	1

PARTS

ILLUSTRATED DRAWING

70.8140 SA250 Install For 4200/4500

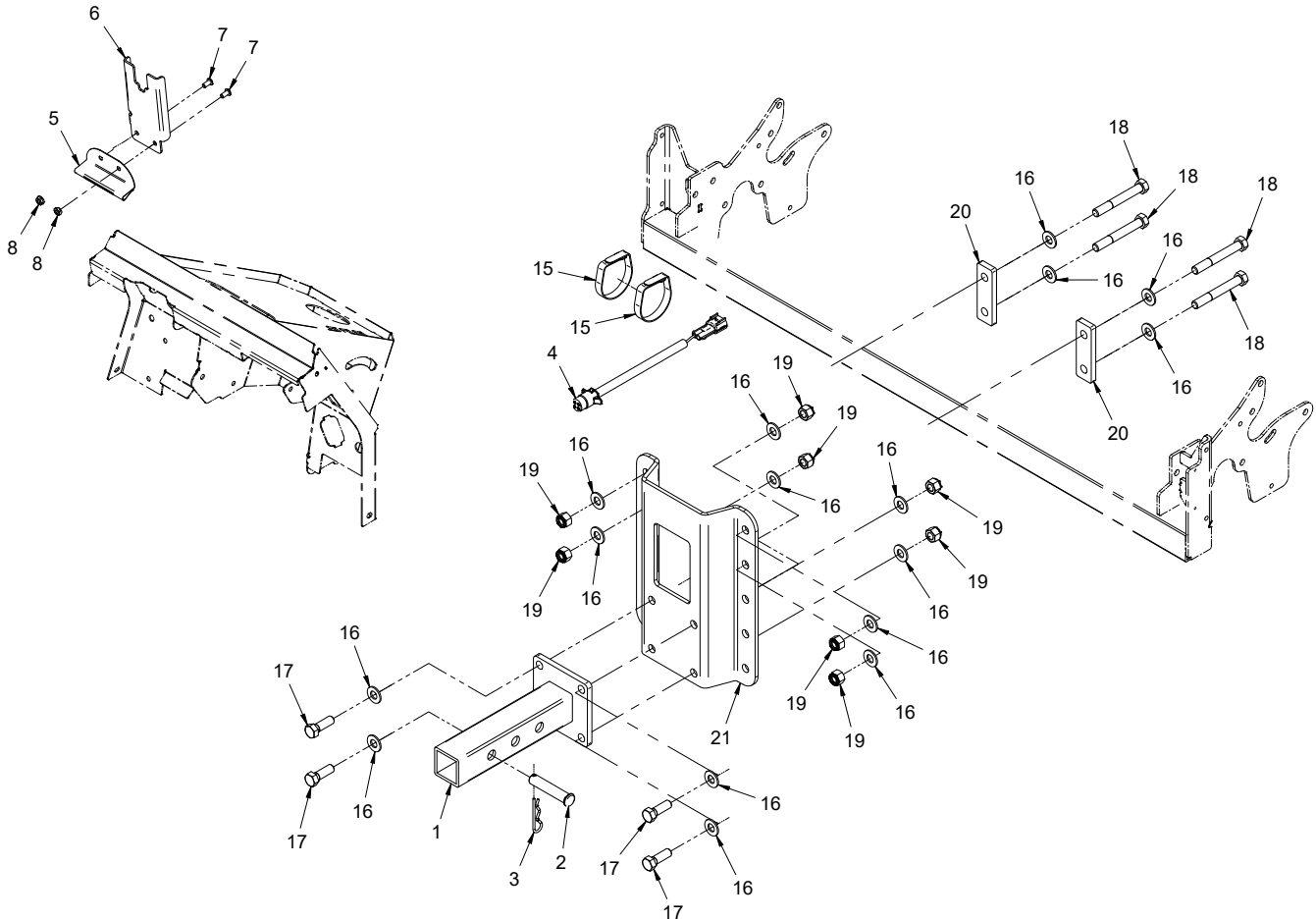
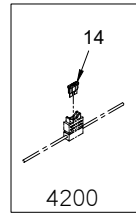
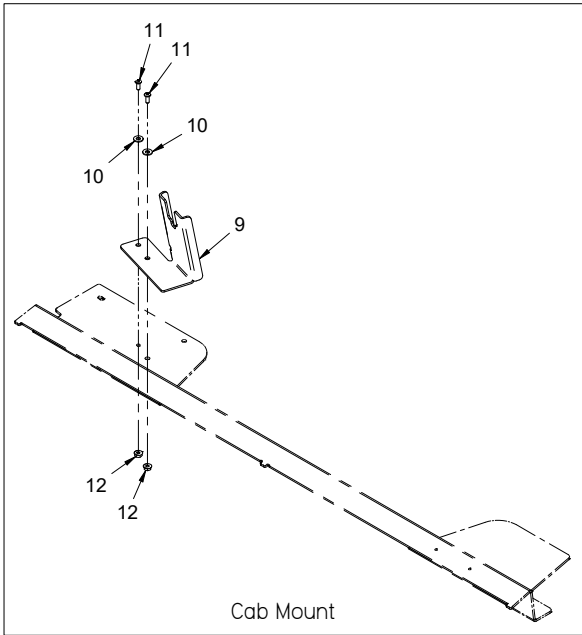

PARTS

70.8140 SA250 Install For 4200/4500

REF.	PART NO.	DESCRIPTION	QTY.
1	62.1412	.HITCH, SA SPREADER 4000 SERIES	1
2	03.1024	.CLEVIS PIN, 5/8 X 3 OAL	1
3	02.HP0420	.HAIRPIN, 1/8 X 2 1/2	1
4	32.0146	.HARNESS, WIRE SA CONN. 4 PIN	1
5	62.1422	.BASE, TRANSMITTER MOUNT	1
6	64.1856	.MOUNT, TRANSMITTER	1
7	99.0404	.BOLT, 1/4-20 X 1/2 BSCS	2
8	99.SF04	.NUT, SRF 1/4-20 USS	2
9	64.1847	.MOUNT, TRANSMITTER 4200/4500	1
10	99.B0051	.WASHER, FLAT #10	2
11	99.K0062	.MACHINE SCREW, #10-32 X 1/2	2
12	99.E0035	.NUT, SRF #10-32	2
14	30.0203	.FUSE, 20 AMP, ATC BLADE YELLOW	1
15	30.0411	.VELCRO, CABLE TIE	2
16	95.08-3	.WASHER, FLAT 1/2 SAE SS	16
17	90.0812-3	.BOLT, 1/2-13 USS X 1-1/2 SS	4
18	90.0830-3	.BOLT, 1/2-13 USS X 3-3/4 SS	4
19	99.A08N-3	.LOCKNUT, NYLON 1/2-13 USS SS	8
20	64.1850	.PLATE, SPREADER HITCH	2
21	64.1849	.MOUNT, SPREADER HITCH	1

PARTS

ILLUSTRATED DRAWING 70.8141 SA250 Install For 3400

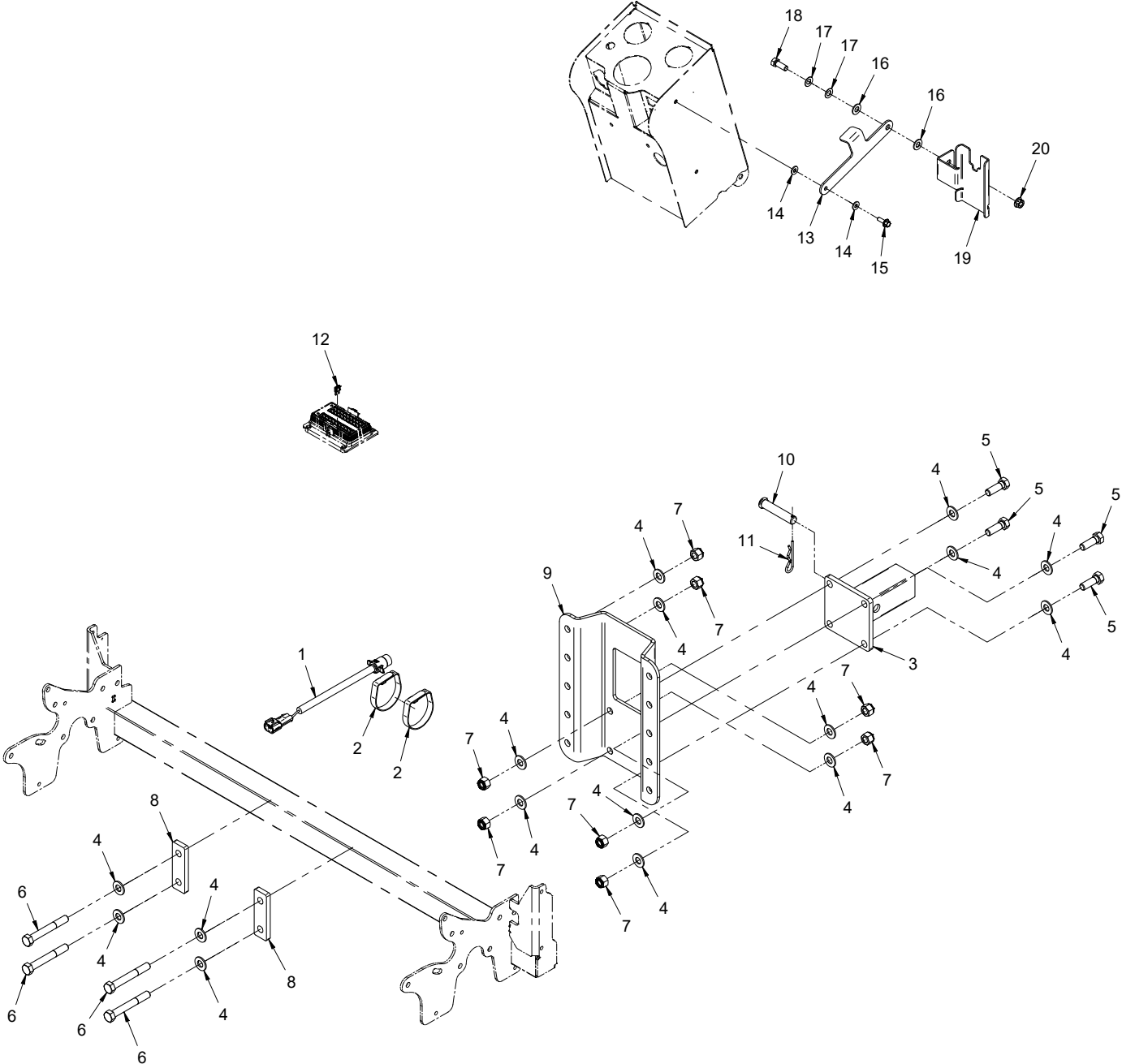

PARTS

70.8141 SA250 Install For 3400

REF.	PART NO.	DESCRIPTION	QTY.
1	32.0146	.HARNES, WIRE SA CONN. 4PIN	1
2	30.0411	.VELCRO, CABLE TIE	2
3	62.1413	.HITCH, SA SPREADER 3000 SERIES	1
4	95.08-3	.WASHER, FLAT 1/2 SAE SS	16
5	90.0812-3	.BOLT, 1/2-13 USS X 1-1/2 SS	4
6	90.0830-3	.BOLT, 1/2-13 USS X 3-3/4 SS	4
7	99.A08N-3	.LOCKNUT, NYLON 1/2-13 USS SS	8
8	64.1850	.PLATE, SPREADER HITCH	2
9	64.1849	.MOUNT, SPREADER HITCH	1
10	03.1024	.CLEVIS PIN, 5/8 X 3 OAL	1
11	02.HP0420	.HAIRPIN, 1/8 X 2 1/2	1
12	30.0335	.FUSE, 20 AMP MINI YELLOW	1
13	64.1534	.BRACKET, CONTROL BOX MOUNT	1
14	95.04	.WASHER, FLAT 1/4 SAE	2
15	99.SF0406-1	.BOLT, SMF 1/4-20 X 3/4	1
16	95.06	.WASHER, FLAT 3/8 SAE	2
17	41.0099	.SPRING, DISC 3/8 ID X 3/4 OD	2
18	90.0608	.BOLT, 3/8-16 USS X 1	1
19	64.1846	.MOUNT, TRANSMITTER 3200/3400	1
20	99.E0082	.NUT, LOCKING FLANGE 3/8-16	1

PARTS

ILLUSTRATED DRAWING

70.8151 SA250 Install For 3100/3200

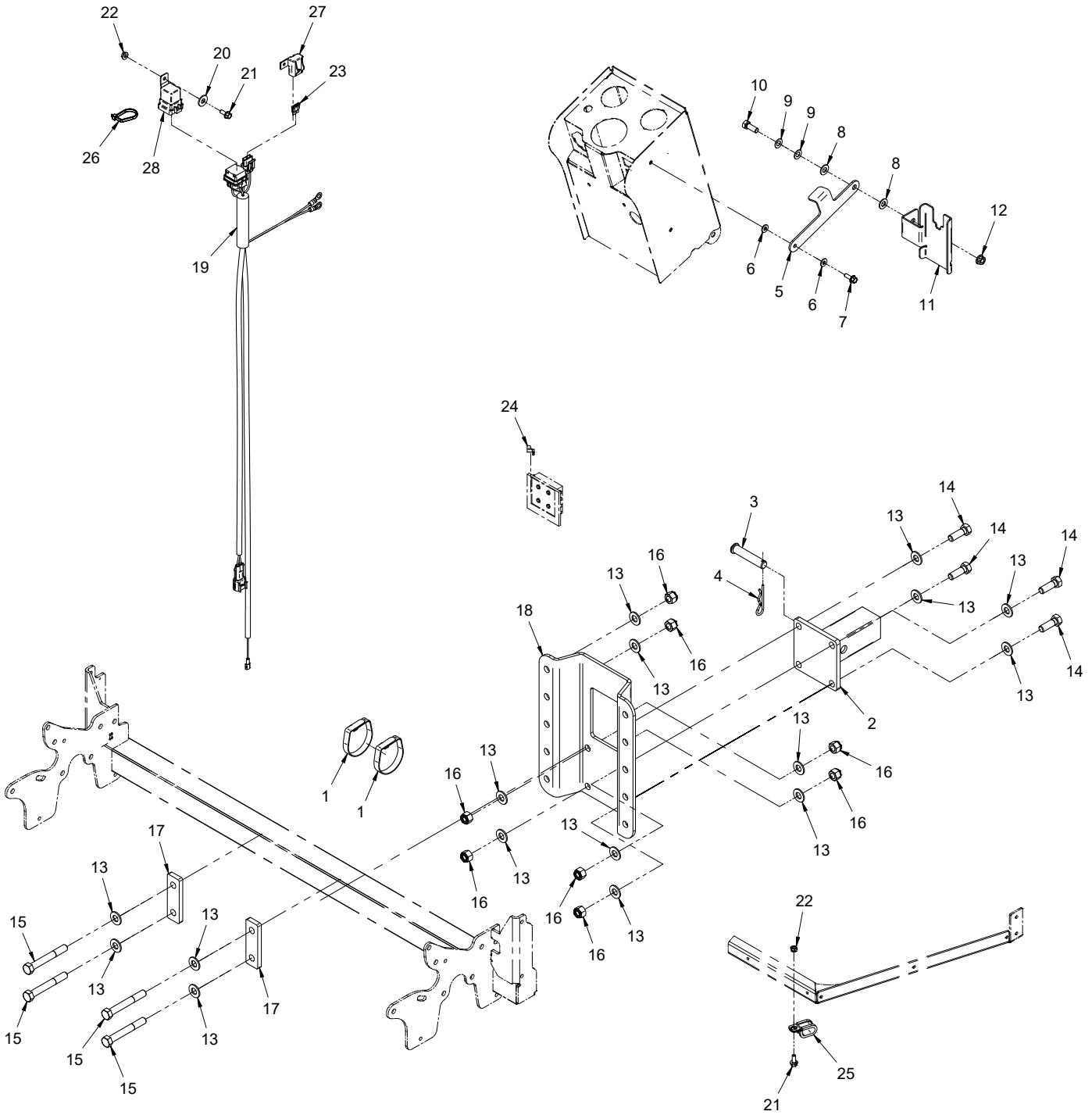

PARTS

70.8151 SA250 Install For 3100/3200

REF.	PART NO.	DESCRIPTION	QTY.
1	30.0411	.VELCRO, CABLE TIE	2
2	62.1413	.HITCH, SA SPREADER 3000 SERIES	1
3	03.1024	.CLEVIS PIN, 5/8 X 3 OAL	1
4	02.HP0420	.HAIRPIN, 1/8 X 2 1/2	1
5	64.1534	.BRACKET, CONTROL BOX MOUNT	1
6	95.04	.WASHER, FLAT 1/4 SAE	2
7	99.SF0406-1	.BOLT, SMF 1/4-20 X 3/4	1
8	95.06	.WASHER, FLAT 3/8 SAE	2
9	41.0099	.SPRING, DISC 3/8 ID X 3/4 OD	2
10	90.0608	.BOLT, 3/8-16 USS X 1	1
11	64.1846	.MOUNT, TRANSMITTER 3200/3400	1
12	99.E0082	.NUT, LOCKING FLANGE 3/8-16	1
13	95.08-3	.WASHER, FLAT 1/2 SAE SS	16
14	90.0812-3	.BOLT, 1/2-13 USS X 1-1/2 SS	4
15	90.0830-3	.BOLT, 1/2-13 USS X 3-3/4 SS	4
16	99.A08N-3	.LOCKNUT, NYLON 1/2-13 USS SS	8
17	64.1850	.PLATE, SPREADER HITCH	2
18	64.1849	.MOUNT, SPREADER HITCH	1
19	32.0163	.HARNESS, WIRE SA CONN. 31/3200	1
20	94.05	.WASHER, FLAT 5/16 USS	1
21	99.SF0405-1	.BOLT, SMF 1/4-20 X 5/8	2
22	99.SF04	.NUT, SRF 1/4-20 USS	2
23	30.0203	.FUSE, 20 AMP, ATC BLADE YELLOW	1
24	30.0146	.TERMINAL, ADAPTER 1/4 PUSH ON	1
25	11.0046	.CLAMP, CUSHIONED METAL 1/2"	1
26	30.0037	.TYTON TIE, #50 .18 X 8 BLACK	4
27	30.0478	.CAP, MP630 FUSE	1
28	35.0122	.RELAY, 12V 20/40A MINI SEALED	1

PARTS

ILLUSTRATED DRAWING 70.8142 SA250 Install Universal 2" Receiver

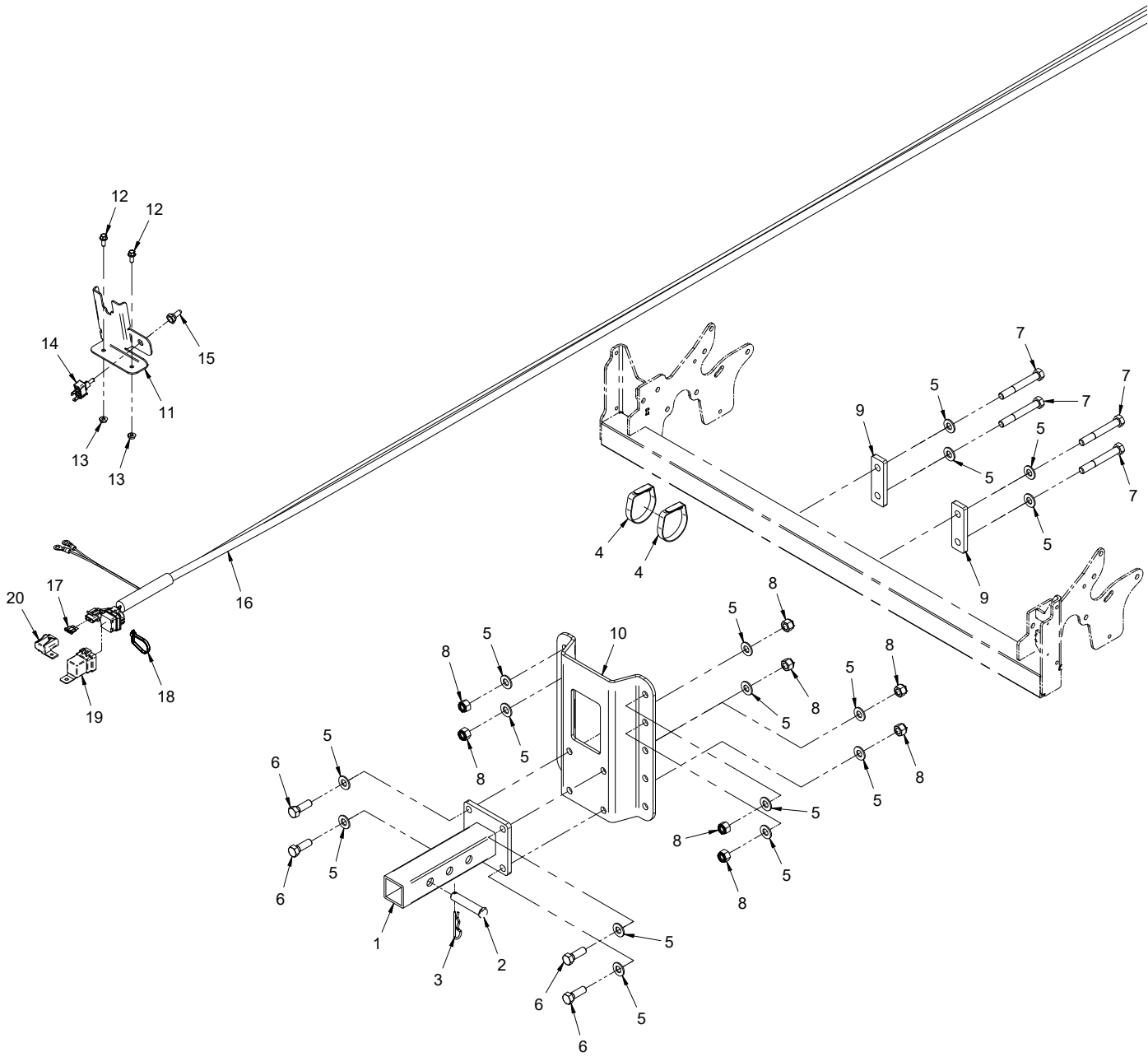

PARTS

70.8142 SA250 Install Universal 2" Receiver

REF.	PART NO.	DESCRIPTION	QTY.
1	62.1412	HITCH, SA SPREADER 4000 SERIES	1
2	03.1024	CLEVIS PIN, 5/8 X 3 OAL	1
3	02.HP0420	HAIRPIN, 1/8 X 2 1/2	1
4	30.0411	VELCRO, CABLE TIE	2
5	95.08-3	WASHER, FLAT 1/2 SAE SS	16
6	90.0812-3	BOLT, 1/2-13 USS X 1-1/2 SS	4
7	90.0830-3	BOLT, 1/2-13 USS X 3-3/4 SS	4
8	99.A08N-3	LOCKNUT, NYLON 1/2-13 USS SS	8
9	64.1850	PLATE, SPREADER HITCH	2
10	64.1849	MOUNT, SPREADER HITCH	1
11	64.1848	MOUNT, TRANSMITTER UNIVERSAL	1
12	99.SF0405-1	BOLT, SMF 1/4-20 X 5/8	2
13	99.SF04	NUT, SRF 1/4-20 USS	2
14	31.0034	SWITCH, TOGGLE ON/OFF SPST	1
15	30.0157	BOOT, TOGGLE SWITCH	1
16	32.0147	HARNESS, WIRE SA CONN. UNIV.	1
17	30.0203	FUSE, 20 AMP, ATC BLADE YELLOW	1
18	30.0037	TYTON TIE, #50 .18 X 8 BLACK	6
19	35.0122	RELAY, 12V 20/40A MINI SEALED	1
20	30.0478	CAP, MP630 FUSE	1

PARTS

ILLUSTRATED DRAWING 70.8143 SA250 Install 3 Point Hitch

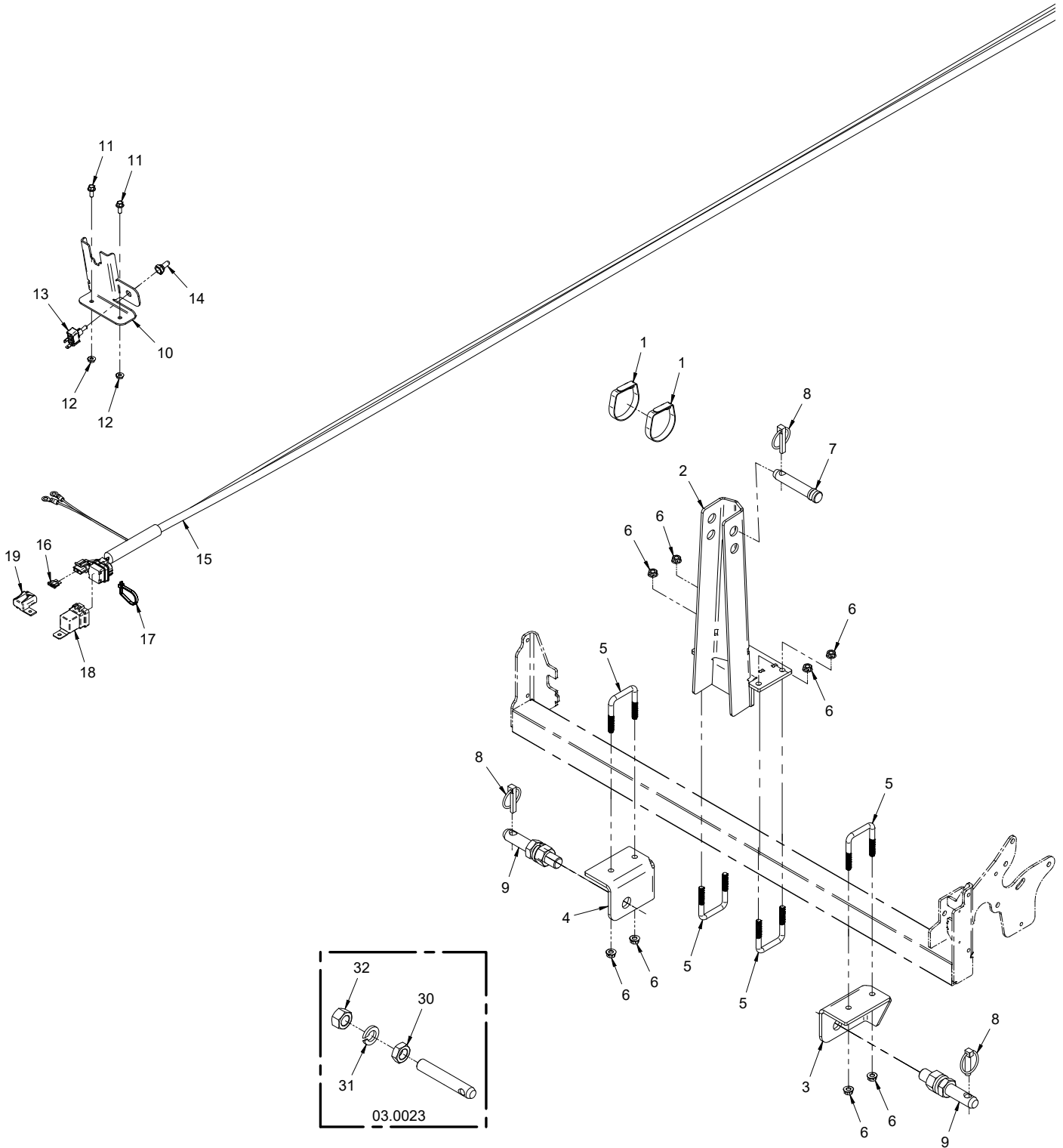

PARTS

70.8143 SA250 Install 3 Point Hitch

REF.	PART NO.	DESCRIPTION	QTY.
1	30.0411	.VELCRO, CABLE TIE	2
2	62.1415	.HITCH, SA SPREADER 3PT TOPLINK	1
3	62.1420	.BRACKET, SA SPREADER 3-PT LEFT	1
4	62.1421	.BRACKET, SA SPREADER 3 PT RIGHT	1
5	11.0053	.U-BOLT, 3/8-16 2-1/16 ID SQ	4
6	99.E0082	.NUT, LOCKING FLANGE 3/8-16	8
7	03.0004	.PIN, TOP LINK CATEGORY 1	1
8	03.0005	.PIN, LINCH	3
9	03.0023	.PIN, LIFT ARM 7/8" X 5-3/4	2
10	64.1848	.MOUNT, TRANSMITTER UNIVERSAL	1
11	99.SF0405-1	.BOLT, SMF 1/4-20 X 5/8	2
12	99.SF04	.NUT, SRF 1/4-20 USS	2
13	31.0034	.SWITCH, TOGGLE ON/OFF SPST	1
14	30.0157	.BOOT, TOGGLE SWITCH	1
15	32.0147	.HARNESS, WIRE SA CONN. UNIV	1
16	30.0203	.FUSE, 20 AMP, ATC BLADE YELLOW	1
17	30.0037	.TYTON TIE, #50 .18 X 8 BLACK	6
18	35.0122	.RELAY, 12V 20/40A MINI SEALED	1
19	30.0478	.CAP, MP630 FUSE	1
30	99.E0074	.NUT, JAM 7/8-14 SAE	1
31	96.14	.WASHER, LOCK 7/8	1
32	93.14	.NUT, 7/8-14 SAE	1

WARRANTY



LIMITED WARRANTY - VENTRAC COMMERCIAL EQUIPMENT

Venture Products, Inc., (henceforth referred to as V.P.I.) warrants on the terms and conditions herein, that it will repair, replace, or adjust any part manufactured by Venture Products Inc., and found by Venture Products, Inc., to be defective in material and/or workmanship during the applicable warranty term.

All Ventrac commercial equipment purchased and registered on or after January 1, 2019 will carry a 2-year commercial warranty. The warranty period begins on the date of original customer purchase:

Ventrac Commercial Equipment	Warranty Term
2100 SSV & Attachments	2-year
3000 Series Tractors & Attachments	2-year
4000 Series Tractors & Attachments	2-year

All Ventrac add-on kits and accessories such as: 3-point hitch, 12V front & rear power outlets, foot pedal, dual wheel kit, etc., will be covered under the above warranty periods provided they are installed by an Authorized Ventrac Dealer. This warranty may be transferred and will carry the remainder of the warranty starting from the original purchase/registration date with the dealership and/or V.P.I.

The engine warranty is covered by its respective engine manufacturer. Please refer to the engine manufacturer's warranty statement that is included in the owner's manual.

For warranty consideration on Ventrac commercial equipment, including any defective part, must be returned to an Authorized Ventrac Dealer within the warranty period. The warranty shall extend to the cost to repair or replace (as determined by V.P.I.) the defective part. The expense of pickup and delivery of equipment, service call drive time or any transportation expense incurred for warranty repair is the sole responsibility of the owner and is not covered under warranty by Ventrac and/or V.P.I. Ventrac and V.P.I.'s responsibility in respect to claims is limited to making the required repairs or replacements, and no claim of breach of warranty shall be cause for cancellation or rescission of the contract of sale of any Ventrac equipment. Proof of purchase may be required by the dealer to substantiate any warranty claim. Only warranty work performed and submitted by an Authorized Ventrac Dealer may be eligible for warranty credit.

This warranty extends only to Ventrac commercial equipment operated under normal conditions and properly serviced and maintained. The warranty expressly does NOT cover: (a) any defects, damage or deterioration due to normal use, wear and tear, or exposure; (b) normal maintenance services, such as cleaning, lubrication, oil change; (c) replacement of service items, such as oil, lubricants, spark plugs, belts, rubber hoses, bearings or other items subject to normal service replacement; (d) damage or defects arising out of, or relating to abuse, misuse, neglect, alteration, negligence or accident; (e) repair or replacement arising from operation of, or use of the equipment which is not in accordance with operating instructions as specified in the operator's manual or other operational instructions provided by V.P.I.; (f) repair or replacement arising as a result of any operation from Ventrac equipment that has been altered or modified so as to, in the determination of V.P.I., adversely affect the operation, performance or durability of the equipment or that has altered, modified or affected the equipment so as to change the intended use of the product; (g) repair or replacement necessitated by the use of parts, accessories or supplies, including gasoline, oil or lubricants, incompatible with the equipment or other than as recommended in the operator's manual or other operational instructions provided by V.P.I.; (h) repairs or replacements resulting from parts or accessories which have adversely affected the operation, performance or durability of the equipment; or (i) damage or defects due to or arising out of repair of Ventrac equipment by person or persons other than an authorized Ventrac service dealer or the installation of parts other than genuine Ventrac parts or Ventrac recommended parts.

WARRANTY



LIMITED WARRANTY - VENTRAC COMMERCIAL EQUIPMENT

The sole liability of V.P.I. with respect to this warranty shall be the repair and replacement as set forth herein. V.P.I. shall have no liability for any other cost, loss, or damage. In particular V.P.I shall have no liability or responsibility for: (i) expenses relating to gasoline, oil, lubricants; (ii) loss, cost or expense relating to transportation or delivery of turf equipment from the location of owner or location where used by owner to or from any Authorized Ventrac Dealer; (iii) travel time, overtime, after hours' time or other extraordinary repair charges or charge relating to repairs or replacements outside of normal business hours at the place of business of an Authorized Ventrac Dealer; (iv) rental of like or similar replacement equipment during the period of any warranty repair or replacement work; (v) any telephone or telegram charges; (vi) loss or damage to person or property other than that covered by the terms of this warranty; (vii) any claims for lost revenue, lost profit or additional cost or expense incurred as a result of a claim of breach of warranty; or (viii) attorney's fees.

The remedies of buyer set forth herein are exclusive and are in lieu of all other remedies. The liability of V.P.I., whether in contract, tort, under any warranty, or otherwise, shall not extend beyond its obligation as set forth herein. V.P.I. shall not be liable for cost of removal or installation nor shall V.P.I. be responsible for any direct, indirect, special or consequential damages of any nature. In no event shall V.P.I. be liable for any sum in excess of the price received for the goods for which liability is claimed.

There are no representations or warranties which have been authorized to the buyer of the Ventrac commercial equipment other than set forth in this warranty. Any and all statements or representations made by any seller of this equipment, including those set forth in any sales literature or made orally by any sales representative, are superseded by the terms of this warranty. Any affirmation of fact or promise made by V.P.I. or any of its representatives to the buyer which relates to the goods that are the subject to this warranty shall not be regarded as part of the basis of the bargain and shall not be deemed to create any express warranty that such goods shall conform to the affirmation or promise.

No employee, distributor, or representative is authorized to change the foregoing warranties in any way or grant any other warranty on behalf of V.P.I.

Some states do not allow limitations on how long an implied warranty lasts or allow the exclusion on limitation of incidental or consequential damages, so the above limitation or exclusion may not apply to you.

This warranty gives you specific legal rights, and you may also have other rights which vary from state to state.

This warranty applies to all Ventrac commercial equipment sold by Venture Products Inc.