

Parts Manual

4520Y

Serial Number 4520Y-AR01001--



Revised 01/24/24
09.20059 Rev. 02



500 Venture Drive
Orrville Oh 44667
www.ventrac.com

View all manuals



Visit ventrac.com/manuals for the latest version of this parts manual. A downloadable operator's manual is also available.

Serial Number Description

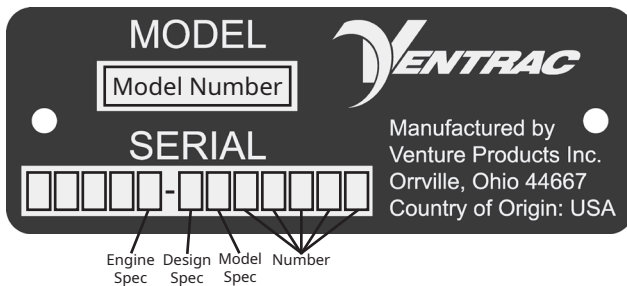

Engine

Y Kubota 25 HP D902-E4B Diesel LC

Notes

- If any component requires replacement, use only original Ventrac replacement parts.
- When ordering new components, be sure to order all required safety decals. All current safety decals must be affixed to the replacement components prior to installation of the component.

TABLE OF CONTENTS

ELECTRICAL	PAGE 7
Wiring Diagram Reference Key (Serial # 01001-02172).....	7
Wiring Diagram - Rear Harness (Serial # 01001-02172).....	8
Wiring Diagram - Front Harness (Serial # 01001-02172).....	9
Wiring Diagram - Engine Harness (Serial # 01001-02172).....	10
Wiring Diagram Reference Key (Serial # 02173-05664).....	11
Wiring Diagram - Rear Harness (Serial # 02173-05664).....	12
Wiring Diagram - Front Harness (Serial # 02173-05664).....	13
Wiring Diagram - Engine Harness (Serial # 02173-05664).....	14
Wiring Diagram Reference Key (Serial # 05665-).....	15
Wiring Diagram - Rear Harness (Serial # 05665-).....	16
Wiring Diagram - Dash Harness (Serial # 05665-).....	17
Wiring Diagram - Front Harness (Serial # 05665-).....	18
Wiring Diagram - Hood Harness (Serial # 05665-).....	19
Wiring Diagram - Kubota Engine Harness (Serial # 05665-).....	20
Wiring Diagram - Optional Female Socket & Male Plug.....	21
Fuse Panel Layout (Serial # 01001-02172).....	22
Fuse Panel Layout (Serial # 02173-05664).....	23
Fuse Panel Layout (Serial # 05665-).....	24
Tractor Control Module (Serial # 01001-02859).....	26
Tractor Control Module (Serial # 02860-).....	28
Battery, Power Cables, & Ground Cables.....	30
Front Fuse Panel (Serial # 01001-02172).....	32
Front Fuse Panel (Serial # 02173-05664).....	34
Front Fuse Panel (Serial # 05665-).....	36
Rear Fuse Panel (Serial # 01001-02172).....	38
Rear Fuse Panel (Serial # 02173-05664).....	40
Rear Fuse Panel (Serial # 05665-).....	42
Power Relay Module.....	44
RPM Sensor.....	46
Speedometer Sensor (Serial # 01001-02652).....	48
Speedometer Sensor (Serial # 02653-03443).....	50
Speedometer Sensor (Serial # 03444-).....	52
HYDRAULICS, AXLES, & WHEELS	PAGE 54
Hydraulic Diagram.....	54
Hydraulic Fitting O-Ring Chart.....	56
Hydraulic Oil Tank.....	58
Hydraulic Steering System.....	60
Front Hitch Hydraulic Lift.....	62
Auxiliary Hydraulic Quick Couplers.....	64
Front Hydraulic Motor Mount & Fittings.....	66
Rear Hydraulic Motor Mount & Fittings.....	68
Hydraulic Pump Mount & Fittings.....	70
Hydraulic Oil Cooler & Fan.....	72
Hydraulic Drive Circuit Hoses.....	74
Pump Supply Line & Main Hydraulic Filter.....	76
Hydraulic Implement Circuit Supply & Return (Serial # 01001-02391).....	78
Hydraulic Implement Circuit Supply & Return (Serial # 02392-).....	80
Front Transaxle & Wheels.....	82

TABLE OF CONTENTS

Rear Transaxle & Wheels (Serial # 01001-05664)	84
Rear Transaxle & Wheels (Serial # 05665-)	86
Peerless Transaxle (51.0087)	88
Danfoss Hydraulic Motor (21.0149)	90
Danfoss Hydraulic Pump (21.0148)	92
2 Spool Valve (23.0201)	94
3 Spool Valve (23.0202)	96
ENGINE	PAGE 98
4520Y Kubota Diesel Engine (Serial # 01001-05664)	98
4520Y Kubota Diesel Engine (Serial # 05665-)	100
4520Y Kubota Diesel Engine Mount	102
4520Y Kubota Diesel PTO Clutch	104
4520Y Kubota Diesel Drive Shaft	106
4520Y Kubota Diesel Muffler	108
4520Y Kubota Diesel Cooling System (Serial # 01001-05576)	110
4520Y Kubota Diesel Cooling System (Serial # 05577-)	112
4520Y Kubota Diesel Air Intake	114
4520Y Kubota Diesel Fuel System	116
FRAMES / SHEET METAL	PAGE 118
Lower Rear Frame (Serial # 01001-05664)	118
Lower Rear Frame (Serial # 05665-)	120
Seat Box & Upper Rear Frame (Serial # 01001-05664)	122
Seat Box & Upper Rear Frame (Serial # 05665-)	124
Left Seat Box Panels	126
Right Seat Box Panels	128
Roll Bar	130
Standard Rear Hitch	132
Rear Fenders & Battery Compartment (Serial # 01001-05664)	134
Rear Fenders & Battery Compartment (Serial # 05665-)	136
Standard Seat Assembly	138
Front Frame, Frame Connector Bracket, Hose Retainer	140
Front Fenders & Foot Pegs	142
Center Pivot & Connector Link	144
Front Hitch	146
Grill & Headlights (Serial # 01001-05664)	148
Grill & Headlights (Serial # 05665-)	150
Hood	152
Dash, Dash Brackets, Decals, & Switches (Serial # 01001-05664)	154
Dash, Dash Brackets, Decals, & Switches (Serial # 05665-)	156
CONTROLS & LINKAGE	PAGE 158
SDLA Control Levers	158
SDLA Linkage	160
Neutral Assist Lever & Neutral Switch	162
Parking Brake Handle, Brake Rod, & Shields	164
Parking Brake Linkage & Brake Drum	166
High/Low Range Shift Linkage	168
PTO Idler Pulley & Idler Arm	170
PTO Belt Tension Linkage	172

TABLE OF CONTENTS

Weight Transfer	174
OPTIONS	PAGE 176
3 Point Hitch Frame (Kit #70.4160).....	176
3 Point Hitch Arms (Kit #70.4160).....	178
3 Point Hitch Hydraulics (Kit #70.4160)	180
3 Point Hitch Hydraulic Diagram (Kit #70.4160)	182
Rear Hydraulic Valve (Kit# 70.4165)	184
Rear Hydraulic Valve Diagram (Kit# 70.4165)	186
70.4098 Wheel Extension Kit.....	188
70.4163 Foot Control Kit	190
70.4108 Raised Platform Kit	192
70.4105 12 Volt Rear Plug Kit (Serial # 01001-02172)	194
70.4179 12 Volt Rear Plug Kit (Serial # 02173-).....	196
70.4120 Horn Kit.....	198
70.4102 Kubota Engine Heater Kit	200
70.4140 Slope Indicator Kit	202
70.4144 Rear Weight Bar Kit	204
Dual Wheels	206
70.4169 Canopy Kit.....	208
70.4170 Canopy Fan Kit	210
70.4171 Strobe Light for Canopy Kit	212
70.4172 Front Work Light for Canopy Kit	214
70.4167 Suspension Seat Kit	216
39.56116 Rear Counterweight Bar	220
70.2016 Trailer Mover Hitch	222
70.4175 Front Hitch Valve Kit (Serial # 01001-05059)	224
70.4187 Front Hitch Valve Kit (Serial # 05060-).....	226
70.4166 Strobe Light Kit	228
70.4173 Work Light LED Kit.....	230
70.4184 Tool Box Mount, Small	232
70.4185 Tool Box Mount, Large	234
70.4161 12 Volt Front Plug Kit.....	236
70.4164 Dual Front Hydraulic Aux Kit	238
70.4162 Directional/Hazard ECE Light Kit.....	240
70.4181 Back-Up Alarm Kit.....	242
70.4137 Mid Weight Bar Kit, 4520	244

Blank Page

ELECTRICAL

Wiring Diagram Reference Key (Serial # 01001-02172)

Wire Reference Key

Harness Section Identifier

A = 32.0219 - Harness, Rear
B = 32.0244 - Harness, Dash
C = 32.0221 - Harness, Front
C = 32.0234 - Harness, Wire 4520 Hood
D = 32.0226 - Harness, B&S Engine
E = 32.0228 - Harness, Kawasaki Engine
F = 32.0223 - Harness, Kubota Gas
G = 32.0227 - Harness, Kubota Diesel
H =
I =
J = 32.0114 - Harness, Kit - 12v Front
K = 32.0113 - Harness, Kit - 12v Rear
L = 32.0225 - Harness, Kit - 12v Dual Hydraulic
M =
N = 32.0121 - Harness, Kit - PTO Remote
O = 32.0115 - Harness, Kit - Horn
P = 32.0122 - Harness, Kit - Backup Alarm
Q = 32.0118 - Harness, Kit - Directional
R = 32.0117 - Harness, Kit - Strobe Light
S = 32.0231 - Harness, Kit - Work Light
U = 32.0166 - Harness, Kit - Slope Indicator

*@ = 32.0160 - Harness, Kubota WG972
" ^ = 32.0159 - Harness, Kawasaki FD851D Fused

* Actual wires not labeled on tractor harness

Wire Color & Circuit Type

Black = Ground
Dark Blue = Pre-Heat
Lt Blue = Safety Circuit
Brown = Engine Run / Kill
Gray = 12v Aux / Horn power
Green = Start/Speed/Directional
Lt Green = 12 Aux
Pink = Alarm
Purple = PTO
Red = Power
Tan = RPM
White = Power
Yellow = Light/Directional

----- = *Black Wire
————— = White Wire
|||———— = Ground
● = Splice or Connection

* All black wires that are part of the wire harness are part of the ground circuit. However, some components such as lights may be wired where black may be positive.

All other wires colors are as shown

Anything outlined with a blue box is a Standard Feature

Anything outlined with a Green box is a Option

ELECTRICAL

Wiring Diagram - Rear Harness (Serial # 01001-02172)

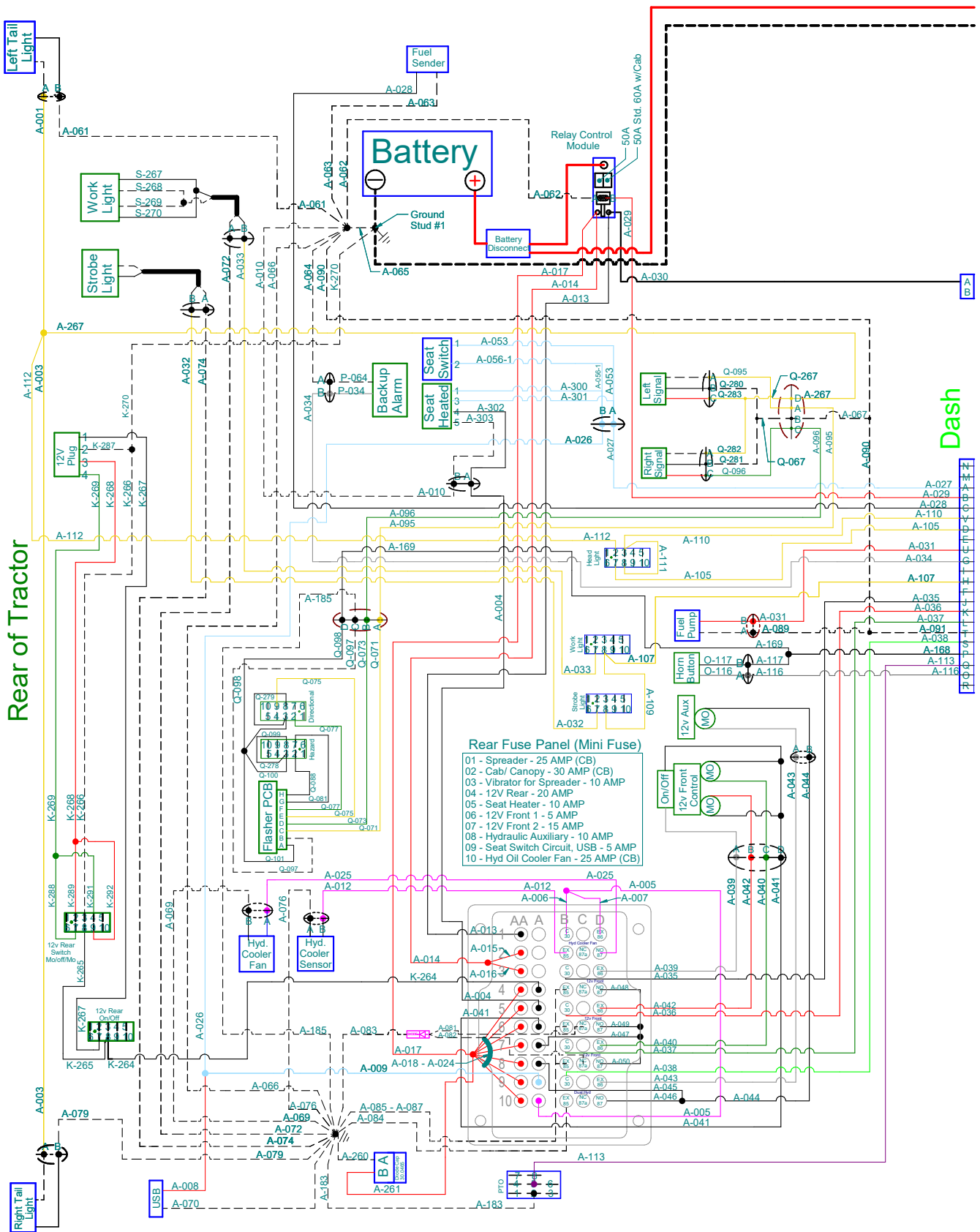

ELECTRICAL

Wiring Diagram - Front Harness (Serial # 01001-02172)

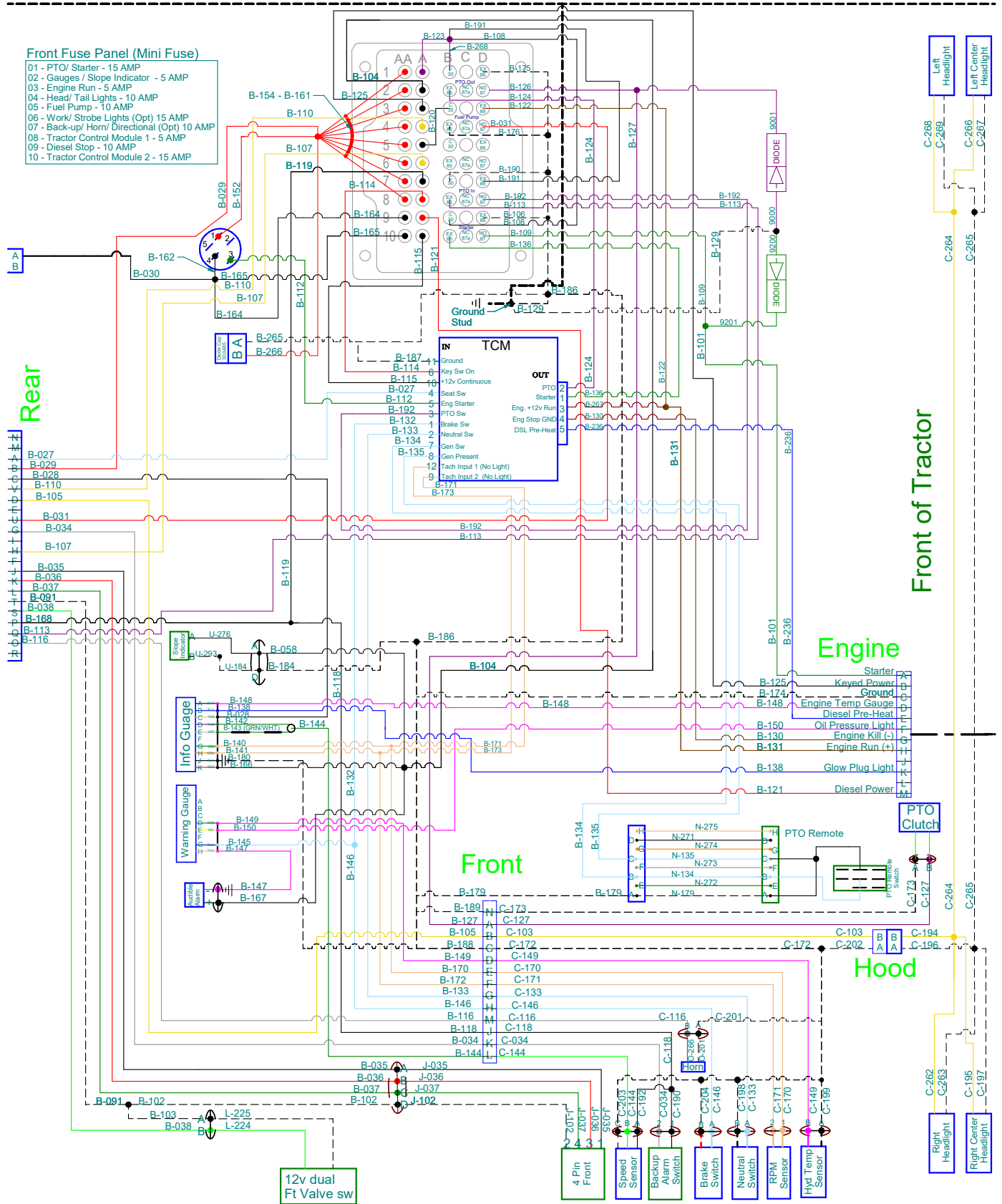

ELECTRICAL

Wiring Diagram - Engine Harness (Serial # 01001-02172)

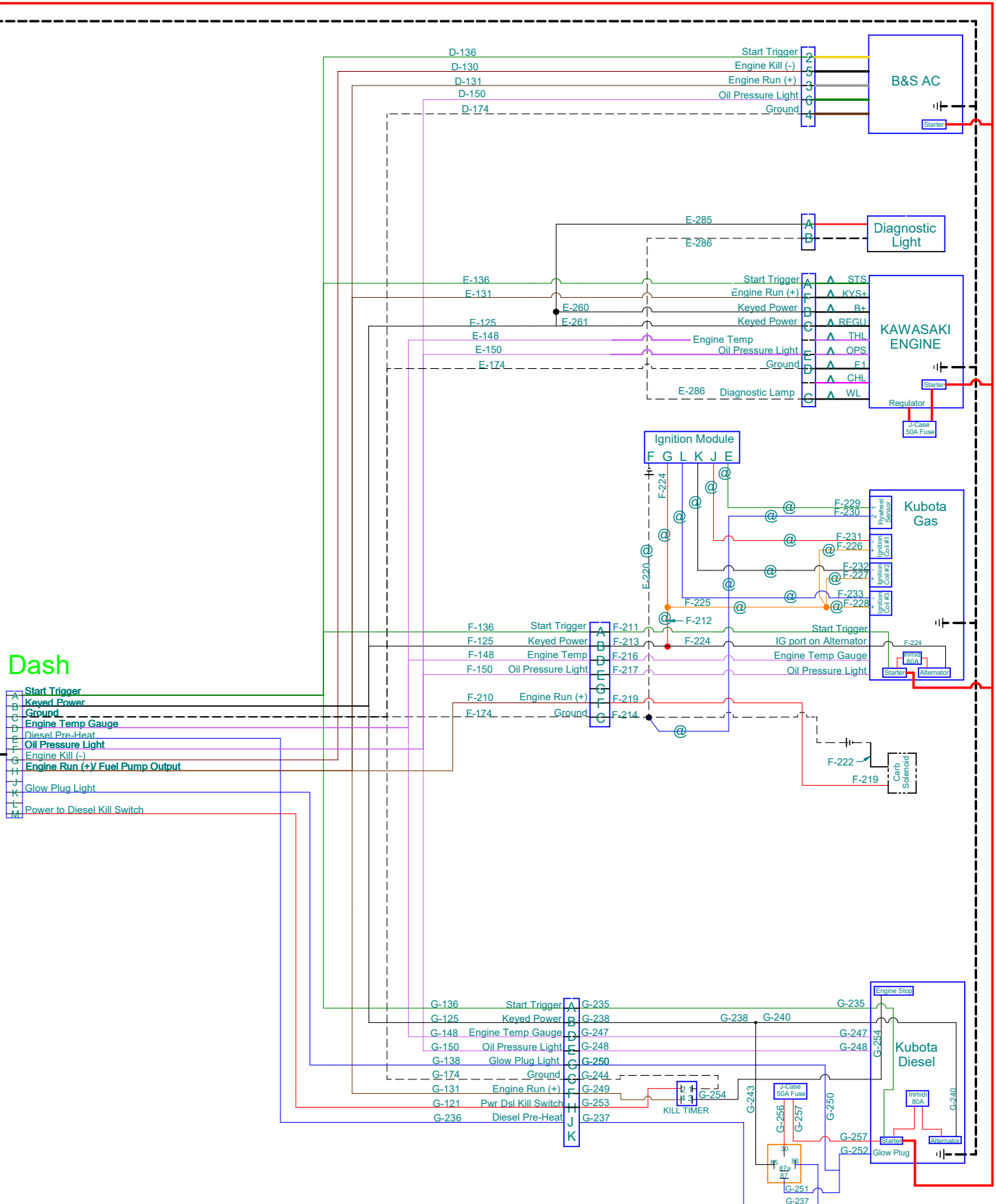

ELECTRICAL

Wiring Diagram Reference Key (Serial # 02173-05664)

Wire Reference Key

Harness Section Identifier

A = 32.0240 - Harness, Rear
B = 32.0241 - Harness, Dash
C = 32.0221 - Harness, Front
C = 32.0234 - Harness, Wire 4520 Hood
D = 32.0226 - Harness, B&S Engine
E = 32.0228 - Harness, Kawasaki Engine
F = 32.0223 - Harness, Kubota Gas
G = 32.0227 - Harness, Kubota Diesel
H =
I =
J = 32.0114 - Harness, Kit - 12v Front
K = 32.0242 - Harness, Kit - 12v Rear
L = 32.0225 - Harness, Kit - 12v Dual Hydraulic
M =
N = 32.0121 - Harness, Kit - PTO Remote
O = 32.0115 - Harness, Kit - Horn
P = 32.0122 - Harness, Kit - Backup Alarm
Q = 32.0118 - Harness, Kit - Directional
R = 32.0117 - Harness, Kit - Strobe Light
S = 32.0231 - Harness, Kit - Work Light
U = 32.0166 - Harness, Kit - Slope Indicator

*@ = 32.0160 - Harness, Kubota WG972
" ^ = 32.0159 - Harness, Kawasaki FD851D Fused

* Actual wires not labeled on tractor harness

Wire Color & Circuit Type

Black = Ground
Dark Blue = Pre-Heat
Lt Blue = Safety Circuit
Brown = Engine Run / Kill
Gray = 12v Aux / Horn power
Green = Start/Speed/Directional
Lt Green = 12 Aux
Pink = Alarm
Purple = PTO
Red = Power
Tan = RPM
White = Power
Yellow = Light/Directional

----- = *Black Wire
————— = White Wire
|||——— = Ground
● = Splice or Connection

* All black wires that are part of the wire harness are part of the ground circuit. However, some components such as lights may be wired where black may be positive.

All other wires colors are as shown

Anything outlined with a blue box is a Standard Feature

Anything outlined with a Green box is a Option

ELECTRICAL

Wiring Diagram - Rear Harness (Serial # 02173-05664)

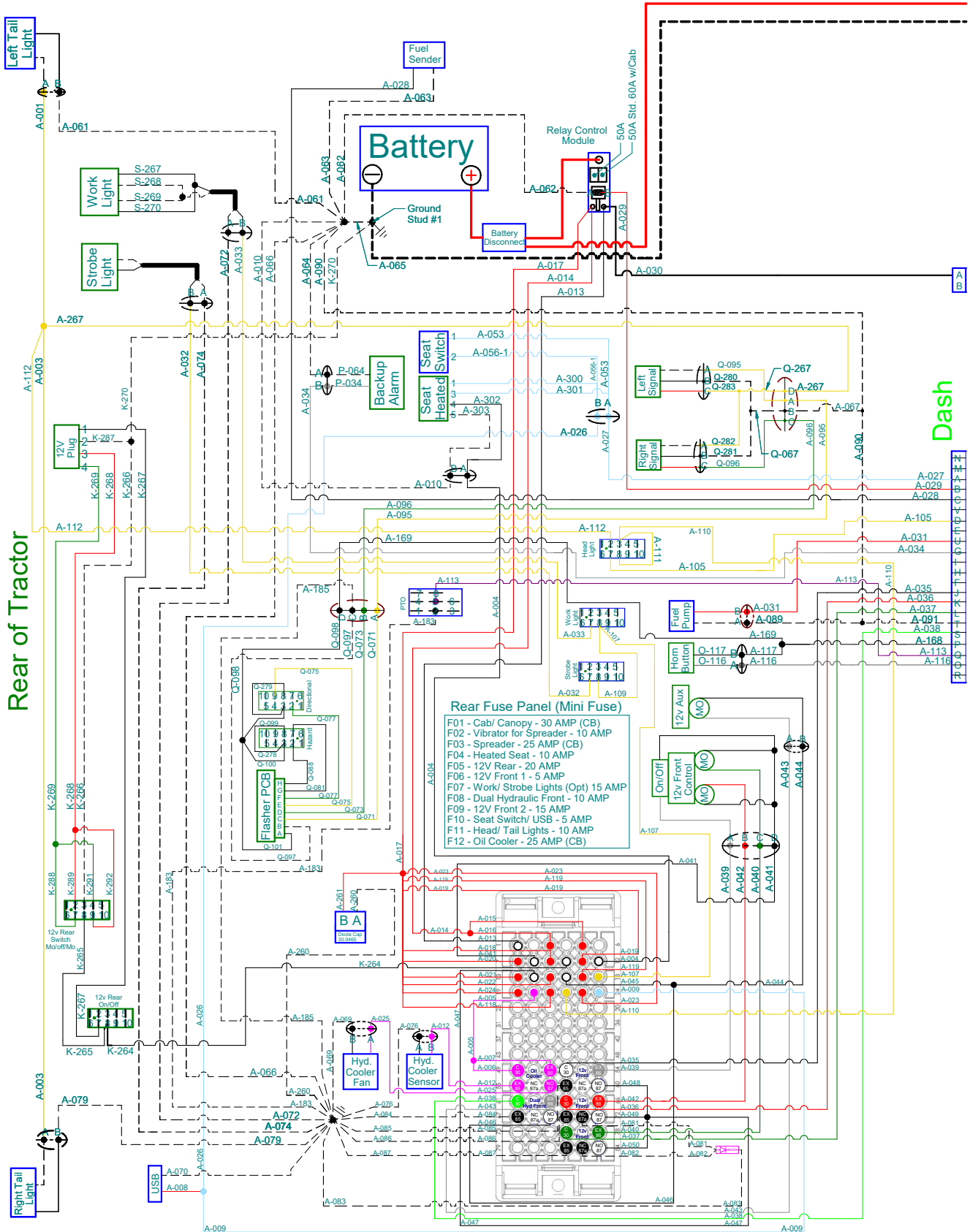

ELECTRICAL

Wiring Diagram - Front Harness (Serial # 02173-05664)

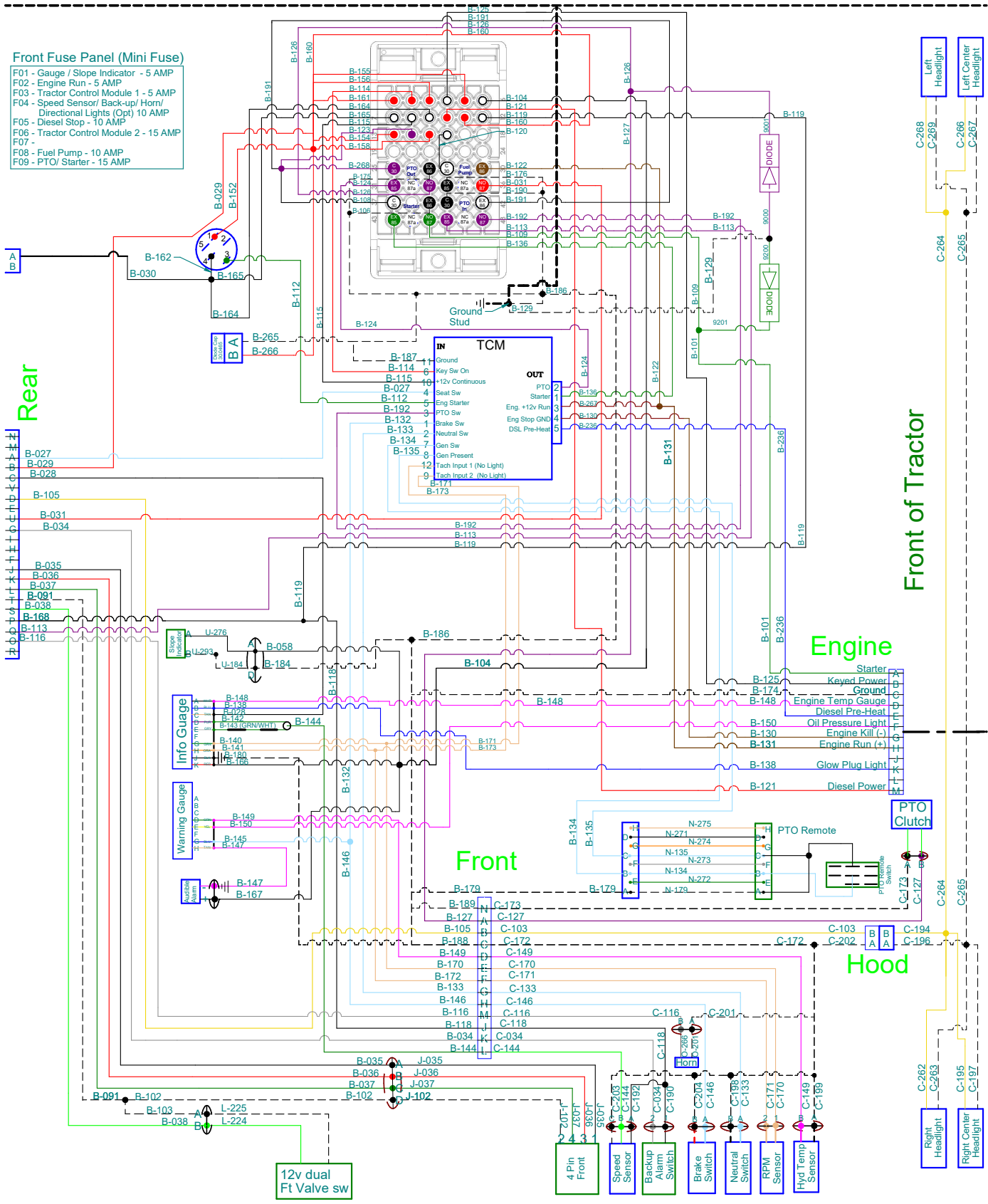

ELECTRICAL

Wiring Diagram - Engine Harness (Serial # 02173-05664)

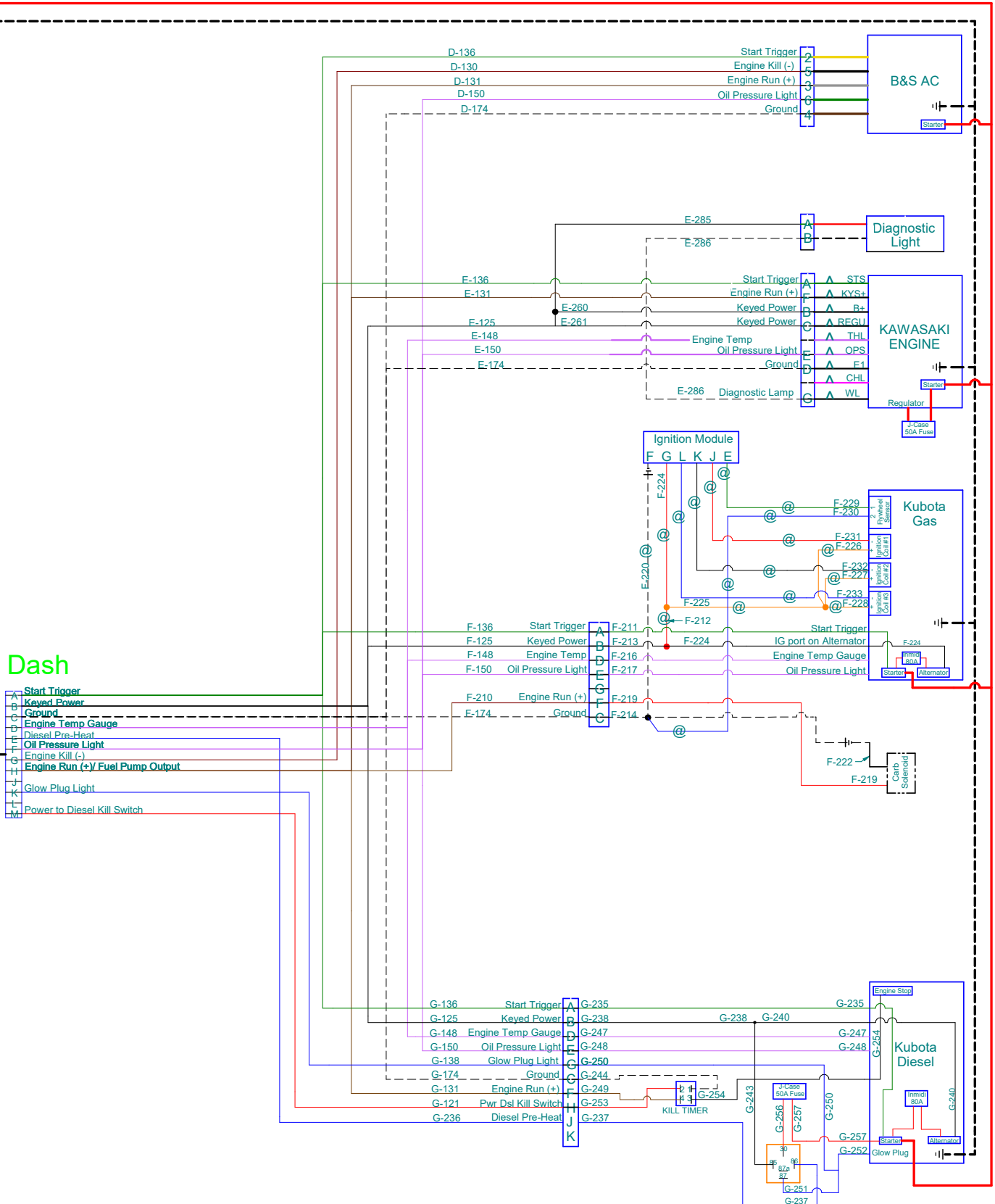

ELECTRICAL



Wiring Diagram Reference Key (Serial # 05665-)

INDEX

Sheet #	WIRING CIRCUIT	WIRE CODE	HARNESS PART #	DESCRIPTION
1	INDEX/REFERENCE PAGE			
2	REAR	A	32.0250	HARNESS, WIRE KN4520 REAR
3	DASH	B	32.0248	HARNESS, WIRE KN4520 DASH
4	FRONT	C	32.0221	HARNESS, WIRE KN4520 FRONT
5	HEADLIGHT	C	32.0234	HARNESS, WIRE KN4520 HOOD
6	KUBOTA 4520Z	F	32.0223	HARNESS, WIRE 4520Z KUBOTA
7	KUBOTA 4520Y	G	32.0227	HARNESS, WIRE 4520Y KUBOTA
8	KAWASAKI 4520P	E	32.0228	HARNESS, WIRE 4520P KAWASAKI
9	VANGUARD 4520K	D	32.0226	HARNESS, WIRE 4520K VANGUARD
10	KUBOTA 4520N	Z	32.0247	HARNESS, WIRE 4520N KUBOTA EFI

WIRE COLOR NAMING CONVENTION

CODE	COLOR	CIRCUIT COLOR DESCRIPTION
BLK	BLACK	GROUND
BRN	BROWN	ENGINE RUN / STOP
GRN	GREEN	START / SPEED
GRY	GRAY	12V AUX / HORN
LBLU	LIGHT BLUE	INTERLOCK
LGRN	LIGHT GREEN	12V AUX
PNK	PINK	ALARM
PUR	PURPLE	PTO
RED	RED	KEYED POWER
TAN	TAN	TACH SIGNAL
WHT	WHITE	DIRECT POWER (DIRECT TO THE BATTERY)
YEL	YELLOW	LIGHTS / DIRECTIONALS

-  = Ground (GND)
 = Splice or Connection (SPL)

ELECTRICAL

Wiring Diagram - Rear Harness (Serial # 05665-)

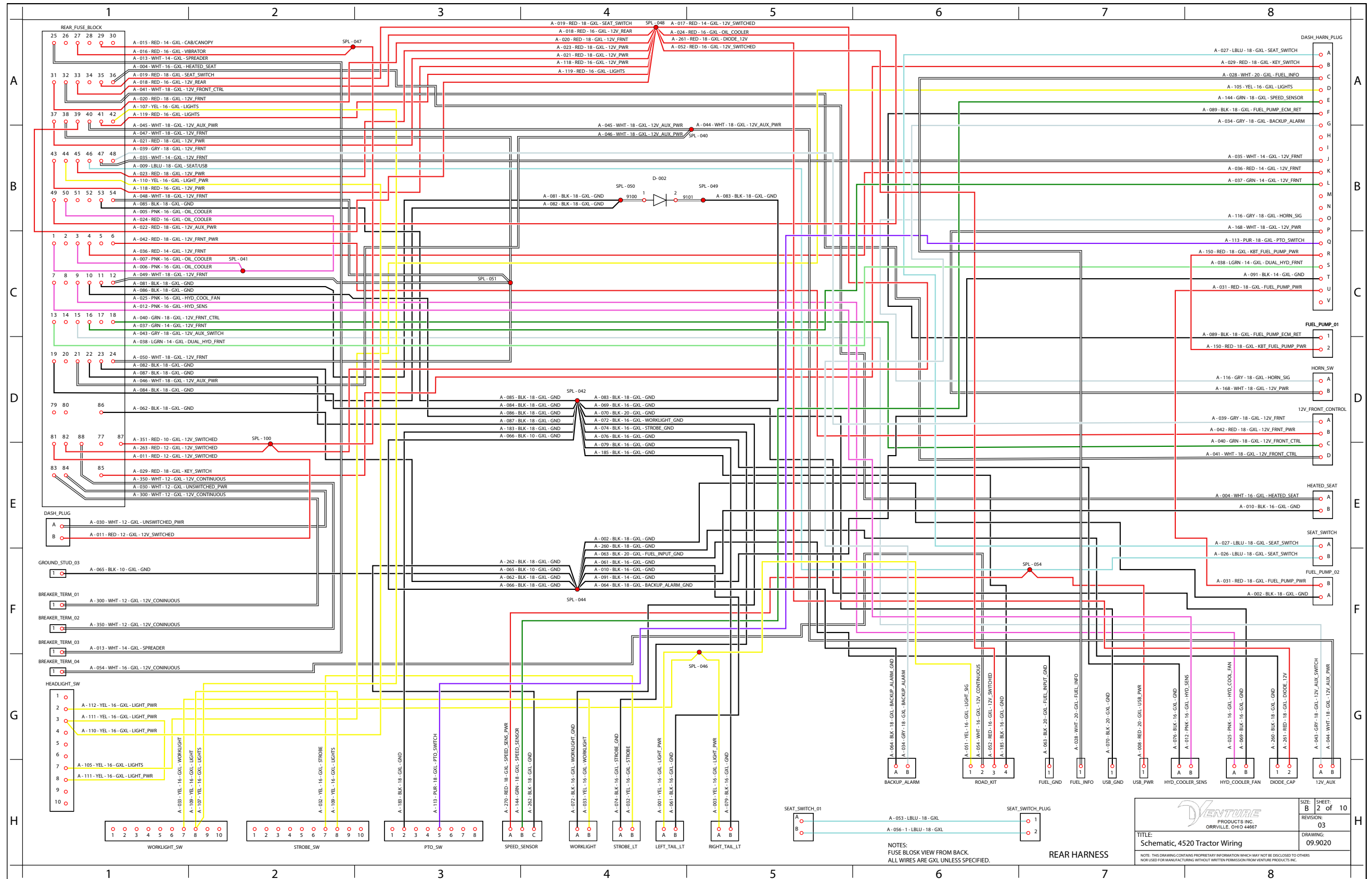

SIZE: B 2 of 10
 REVISION: 03
 DRAWING: 09.9020

VENTURE PRODUCTS INC.
 ORRVILLE, OHIO 44667

TITLE: Schematic, 4520 Tractor Wiring
 NOTE: THIS DRAWING CONTAINS PROPRIETARY INFORMATION WHICH MAY NOT BE DISCLOSED TO OTHERS NOR USED FOR MANUFACTURING WITHOUT WRITTEN PERMISSION FROM VENTURE PRODUCTS INC.

REAR HARNESS

NOTES:
 FUSE BLOCK VIEW FROM BACK.
 ALL WIRES ARE GXL UNLESS SPECIFIED.

ELECTRICAL

Wiring Diagram - Dash Harness (Serial # 05665-)

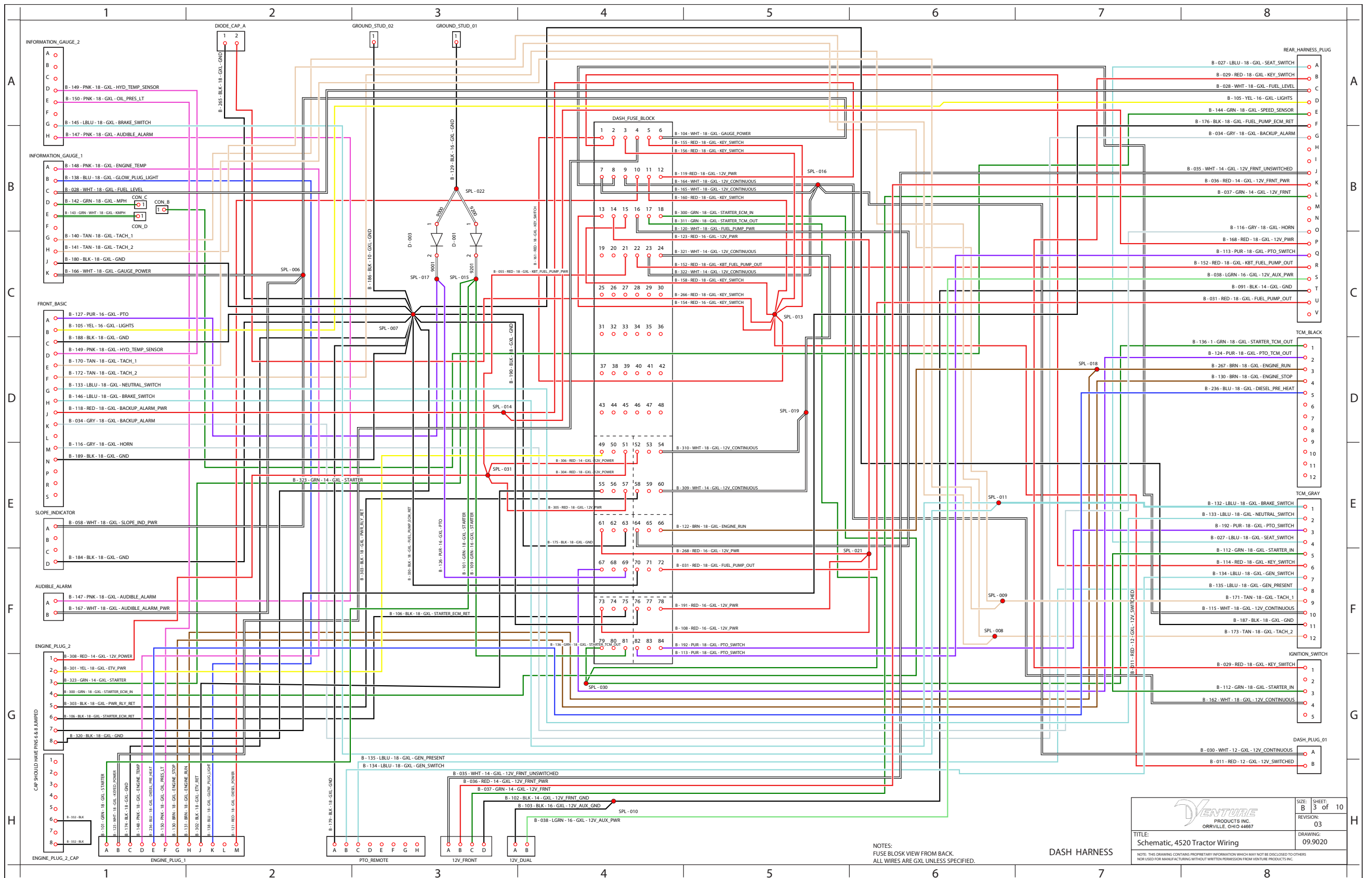

VENTURE PRODUCTS INC. ORRVILLE, OHIO 44667	
TITLE: Schematic, 4520 Tractor Wiring	SIZE: B SHEET: 3 of 10 REVISION: 03 DRAWING: 09.9020
NOTE: THIS DRAWING CONTAINS PROPRIETARY INFORMATION WHICH MAY NOT BE DISCLOSED TO OTHERS NOR USED FOR MANUFACTURING WITHOUT WRITTEN PERMISSION FROM VENTURE PRODUCTS INC.	

ELECTRICAL

Wiring Diagram - Front Harness (Serial # 05665-)

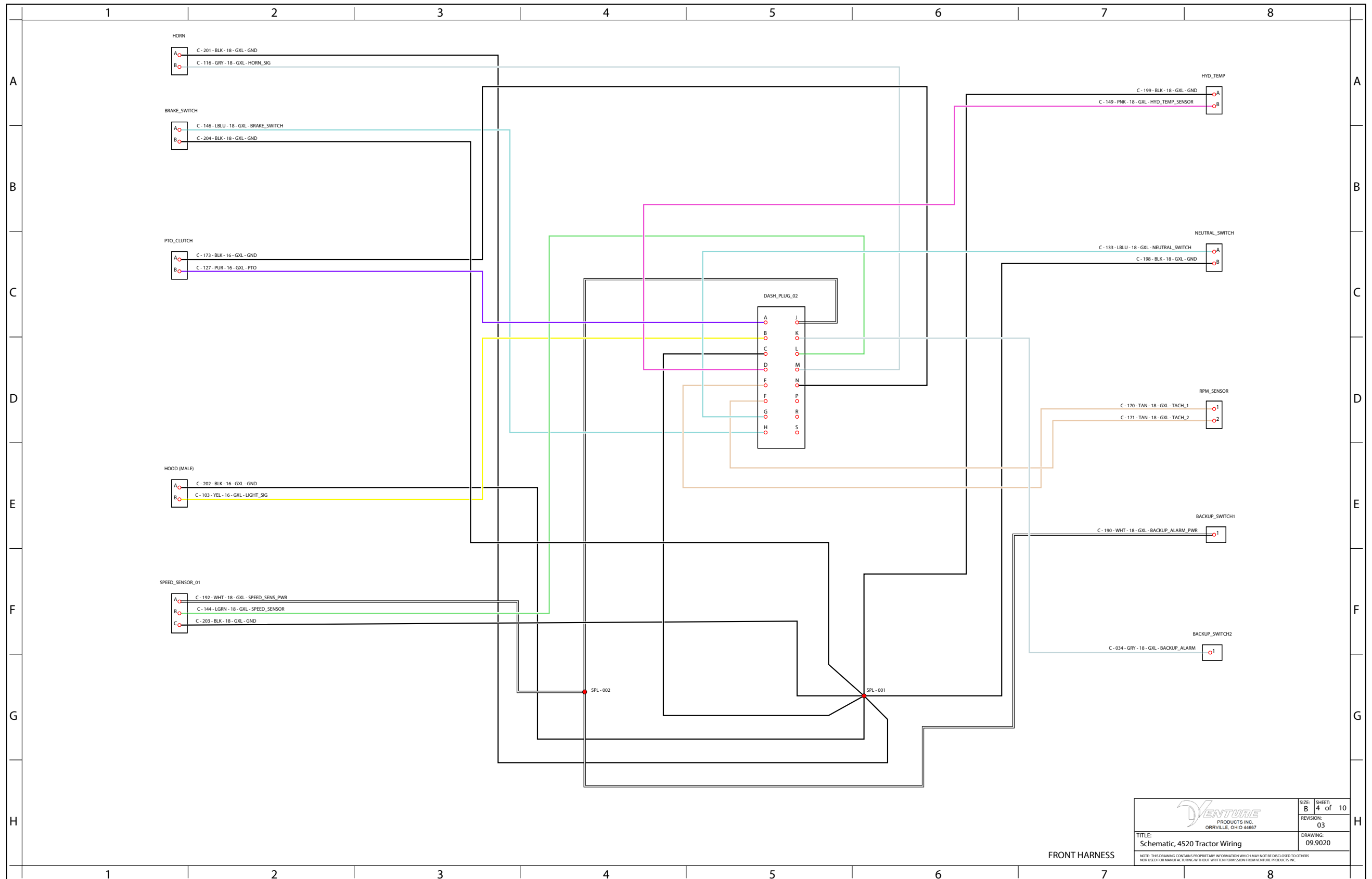

FRONT HARNESS

<p>VENTURE PRODUCTS INC. ORRVILLE, OHIO 44667</p>		SIZE: B	SHEET: 4 of 10
		REVISION: 03	DRAWING: 09.9020
<p>TITLE: Schematic, 4520 Tractor Wiring</p>		<p>NOTE: THIS DRAWING CONTAINS PROPRIETARY INFORMATION WHICH MAY NOT BE DISCLOSED TO OTHERS NOR USED FOR MANUFACTURING WITHOUT WRITTEN PERMISSION FROM VENTURE PRODUCTS INC.</p>	

ELECTRICAL

Wiring Diagram - Hood Harness (Serial # 05665-)

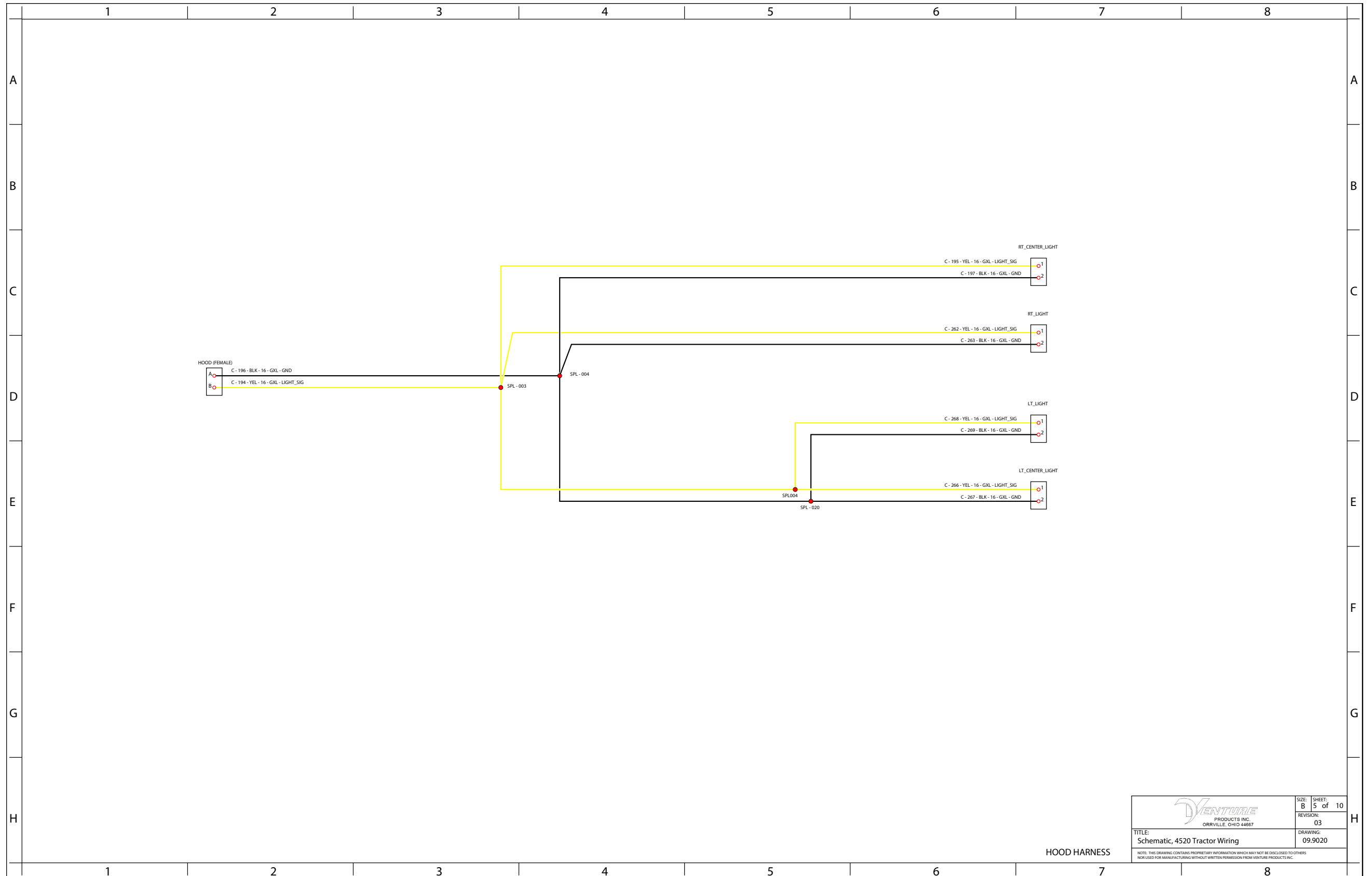

HOOD HARNESS

 PRODUCTS INC. ORRVILLE, OHIO 44667		SIZE: B	SHEETS: 5 of 10
		REVISION: 03	DRAWING: 09.9020
TITLE: Schematic, 4520 Tractor Wiring <small>NOTE: THIS DRAWING CONTAINS PROPRIETARY INFORMATION WHICH MAY NOT BE DISCLOSED TO OTHERS NOR USED FOR MANUFACTURING WITHOUT WRITTEN PERMISSION FROM VENTURE PRODUCTS INC.</small>			

ELECTRICAL

Wiring Diagram - Kubota Engine Harness (Serial # 05665-)

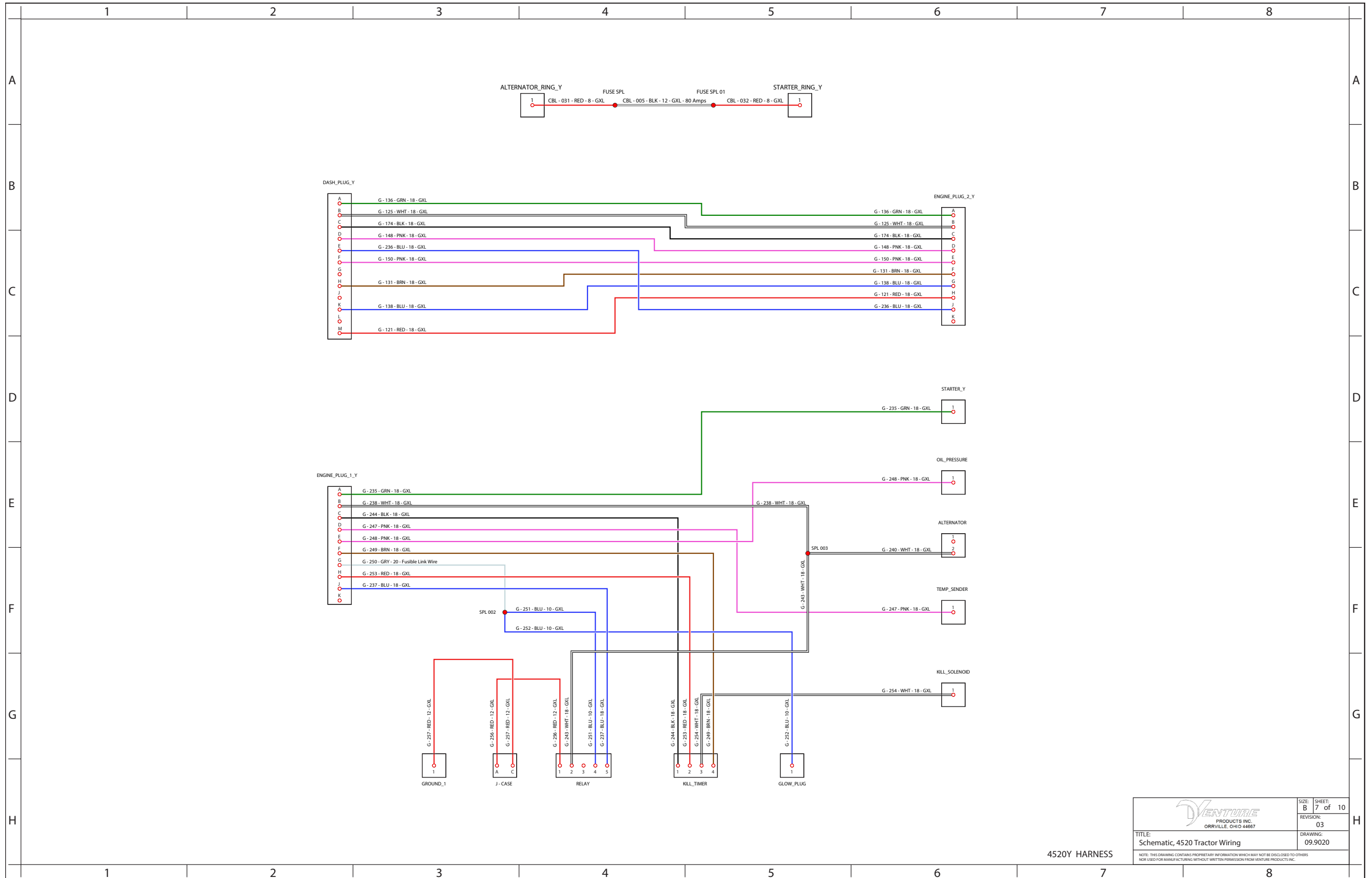

4520Y HARNESS

 VENTURE PRODUCTS INC. ORRVILLE, OHIO 44667		SIZE: B SHEET: 7 of 10 REVISION: 03
TITLE: Schematic, 4520 Tractor Wiring		DRAWING: 09.9020
<small>NOTE: THIS DRAWING CONTAINS PROPRIETARY INFORMATION WHICH MAY NOT BE DISCLOSED TO OTHERS NOR USED FOR MANUFACTURING WITHOUT WRITTEN PERMISSION FROM VENTURE PRODUCTS INC.</small>		

ELECTRICAL

Wiring Diagram - Optional Female Socket & Male Plug

Attention

This connector (4-pin socket) is designed for use with Ventrac original equipment only.
This connector (4-pin socket) is rated for 20 amp maximum current draw. Engine alternator and/or battery capacity determine allowable continuous draw.

30.0219 4-pin female socket is used in the 70.4161 12 Volt Front kit & 70.4105 12 Volt Rear Kit.

**Front View of Socket
Without Cover**

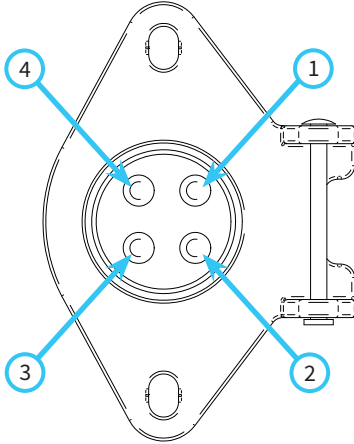

Rear View of Socket

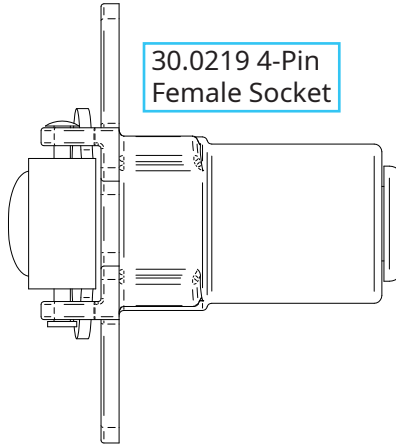
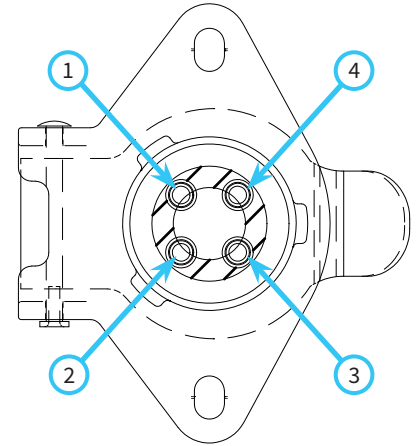

Terminal Position	Wire Color	Function
1	White	Positive (On/Off Switched)
2	Black	Negative (Constant)
3	Red	Positive/Negative (Momentary Switched Reversing)
4	Green or Brown	Positive/Negative (Momentary Switched Reversing)

30.0218 4-pin plug is used on attachments to connect to the 30.0219 socket on the power unit.

Front View of Plug

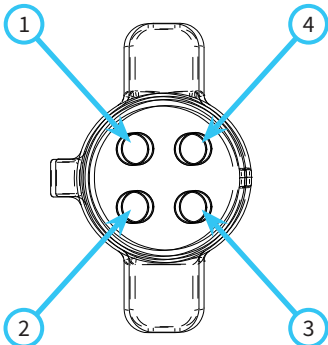

Rear View of Plug

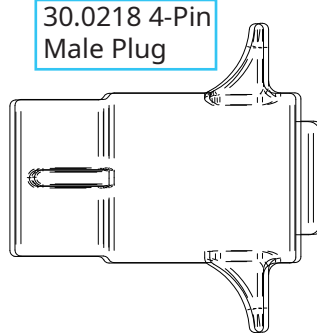
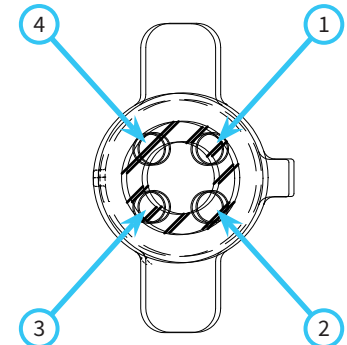

Terminal Position	Wire Color	Function
1	Not Specified*	Positive (On/Off Switched)
2	Not Specified*	Negative (Constant)
3	Not Specified*	Positive/Negative (Momentary Switched Reversing)
4	Not Specified*	Positive/Negative (Momentary Switched Reversing)

* Refer to the part diagram in the attachment's parts manual for specific wire color and terminal position for each model.

ELECTRICAL

Fuse Panel Layout (Serial # 01001-02172)

Front Fuse Panel

Relays		
Location	Function	P/N
R01	PTO Out	35.0117
R02	Fuel Pump	35.0117
R03	-	-
R04	PTO In	35.0117
R05	Starter	35.0117

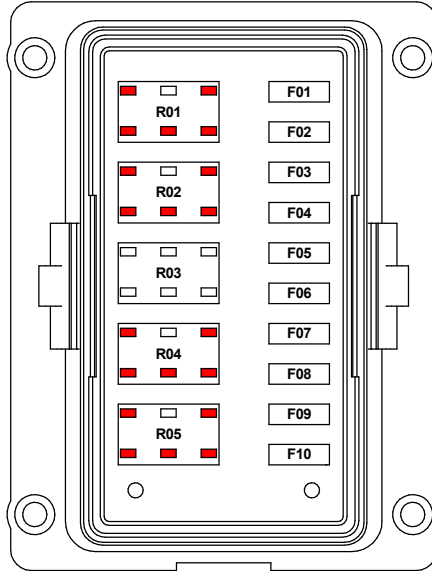

Fuses			
Location	Fuse (Amps)	Circuit	P/N
F01	15	PTO	30.0334
F02	5	Gauges / Slope Indicator	30.0332
F03	5	Engine Run	30.0332
F04	10	Head / Tail Lights	30.0333
F05	10	Fuel Pump	30.0333
F06	15*	Work / Strobe Lights	30.0334
F07	10	Speed Sensor / Back-up / Horn / Directional	30.0333
F08	5	Tractor Control Module 1	30.0332
F09	10^	Diesel Stop	30.0333
F10	15	Tractor Control Module 2	30.0334

*Optional accessory
^4520Y only

Rear Fuse Panel

Relays		
Location	Function	P/N
R01	Hydraulic Oil Cooler Fan	35.0117
R02	12V Front*	35.0117
R03	12V Front*	35.0117
R04	12V Front*	35.0117
R05	Dual Hyd. Auxiliary*	35.0117

*Optional accessory

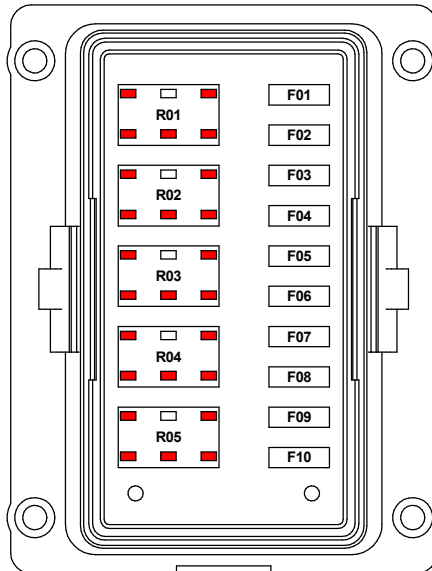

Fuses			
Location	Fuse (Amps)	Circuit	P/N
F01	25 (CB)*	Spreader	30.0429
F02	30 (CB)*	Cab / Canopy	30.0445
F03	10*	Vibrator for Spreader	30.0333
F04	20*	12V Rear	30.0335
F05	10*	Seat Heater	30.0333
F06	5*	12V Front 1	30.0332
F07	15*	12V Front 2	30.0334
F08	10*	Dual Hyd. Auxiliary	30.0333
F09	5	Seat Switch, USB	30.0332
F10	25 (CB)	Hydraulic Oil Cooler Fan	30.0429

*Optional accessory
(CB) = Circuit Breaker

ELECTRICAL

Fuse Panel Layout (Serial # 02173-05664)

Front Fuse Panel

Relays		
Location	Function	P/N
R01	PTO (Input)	35.0117
R02	Starter	35.0117
R03	Fuel Pump	35.0117
R04	PTO (Output)	35.0117

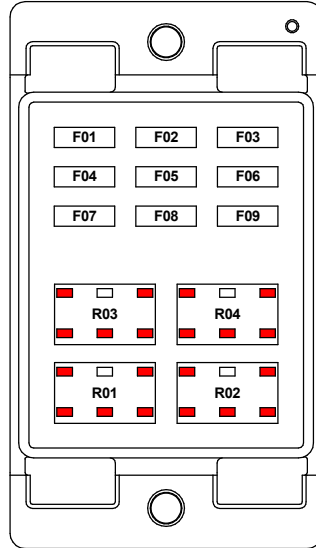

Fuses			
Location	Fuse (Amps)	Circuit	P/N
F01	5	Gauge / Slope Indicator	30.0332
F02	5	Engine Run	30.0332
F03	5	Tractor Control Module 1	30.0332
F04	10	Speed Sensor / Back-up / Horn / Directional	30.0333
F05	10*	Diesel Stop	30.0333
F06	15	Tractor Control Module 2	30.0334
F07	-	Blank	-
F08	10	Fuel Pump	30.0333
F09	15	PTO / Starter	30.0334

*4520Y only

Rear Fuse Panel

Relays		
Location	Function	P/N
R01	12V Front [^]	35.0117
R02	Blank	-
R03	12V Front [^]	35.0117
R04	Dual Hydraulic Front [^]	35.0117
R05	12V Front [^]	35.0117
R06	Oil Cooler	35.0117

[^]Optional accessory

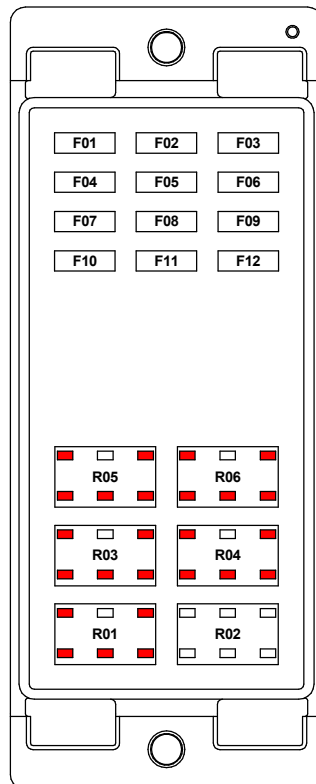

Fuses			
Location	Fuse (Amps)	Circuit	P/N
F01	30 (CB) [^]	Cab / Canopy	30.0445
F02	10 [^]	Vibrator for Spreader	30.0333
F03	25 (CB) [^]	Spreader	30.0429
F04	10 [^]	Heated Seat	30.0333
F05	20 [^]	12V Rear	30.0335
F06	5 [^]	12V Front 1	30.0332
F07	15 [^]	Work / Strobe Lights	30.0334
F08	10 [^]	Dual Hydraulic Front	30.0333
F09	15 [^]	12V Front 2	30.0334
F10	5	Seat Switch / USB	30.0332
F11	10	Head / Tail Lights	30.0333
F12	25 (CB)	Oil Cooler	30.0429

[^]Optional accessory

(CB) = Circuit Breaker

ELECTRICAL

Fuse Panel Layout (Serial # 05665-)

Front Fuse Panel

Relays		
Location	Function	P/N
R01	PTO (Input)	35.0117
R02	Starter	35.0117
R03	Fuel Pump [#]	35.0117
R04	PTO (Output)	35.0117
R05	Kubota Power ^{&}	35.0117
R06	Kubota ETV ^{&}	35.0117

[#] not used on 4520N

[&] 4520N only

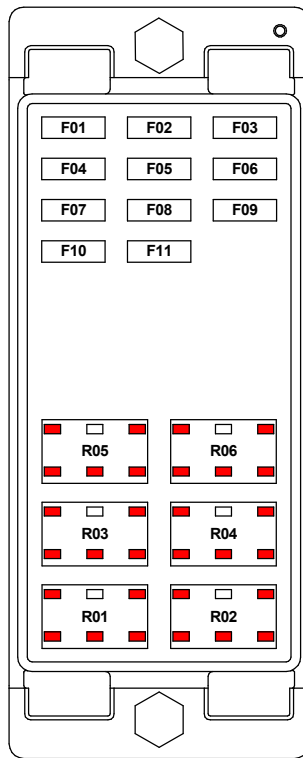

Fuses			
Location	Fuse (Amps)	Circuit	P/N
F01	5	Gauge	30.0332
F02	5	Engine Run	30.0332
F03	5	Tractor Control Module 1	30.0332
F04	10 [^]	Back-up Alarm / Horn	30.0333
F05	10 [*]	Diesel Stop	30.0333
F06	15	Tractor Control Module 2	30.0334
F07	5 ^{&}	ECM Start	30.0332
F08	10 [#]	Fuel Pump 02 (Standard)	30.0333
F09	15	PTO / Starter	30.0334
F10	30 ^{&}	Kubota Power	30.0337
F11	5 ^{&}	Fuel Pump 01 (4520N)	30.0332

[^] Optional Accessory

^{*}4520Y only

[#] not used on 4520N

[&] 4520N only

Rear Fuse Panel

Relays		
Location	Function	P/N
R01	Keyed Power	35.0167
R02	12V Front [^]	35.0117
R03	Dual Hydraulic Front [^]	35.0117
R04	12V Front [^]	35.0117
R05	Oil Cooler	35.0117
R06	12V Front [^]	35.0158

[^]Optional accessory

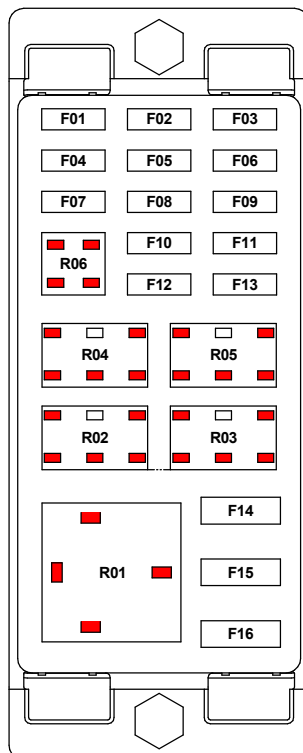

Fuses			
Location	Fuse (Amps)	Circuit	P/N
F01	30 (CB) [^]	Cab / Canopy	30.0445
F02	10 [^]	Vibrator for Spreader	30.0333
F03	25 (CB) [^]	Spreader	30.0429
F04	10 [^]	Heated Seat	30.0333
F05	20 [^]	12V Rear	30.0335
F06	5 [^]	12V Front 1	30.0332
F07	15 [^]	Work / Strobe Lights	30.0334
F08	10 [^]	Dual Hydraulic Front	30.0333
F09	15 [^]	12V Front 2	30.0334
F10	5	Seat Switch / USB / Speed Sensor	30.0332
F11	10	Head / Tail Lights	30.0333
F12	-	Blank	
F13	25 (CB)	Oil Cooler	30.0429
ATC Fuses			
F14	-	Blank	
F15	40	Keyed Power	30.0188
F16	40	Continuous Power	30.0188

[^]Optional accessory

(CB) = Circuit Breaker

Blank Page

ELECTRICAL

ILLUSTRATED DRAWING

Tractor Control Module (Serial # 01001-02859)

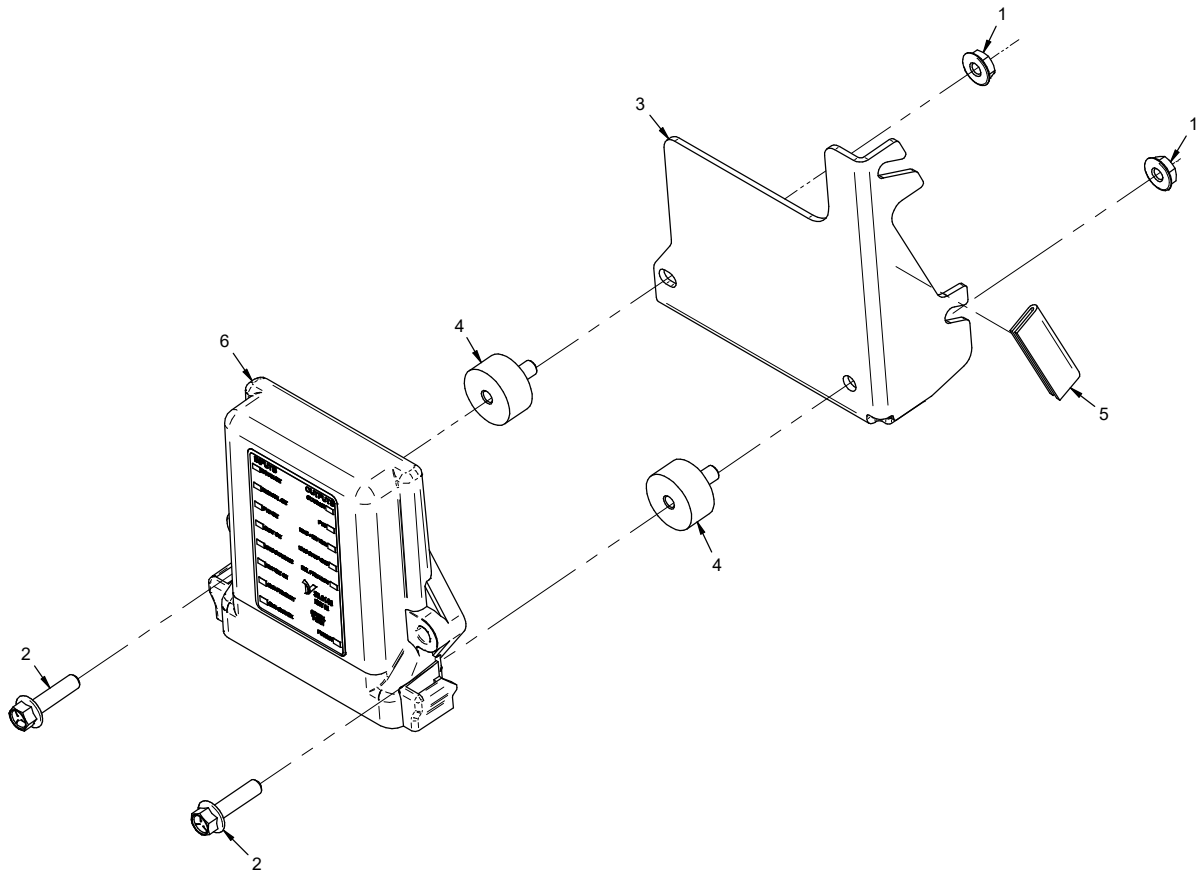

ELECTRICAL

Tractor Control Module (Serial # 01001-02859)

REF.	PART NO.	DESCRIPTION	QTY.
1	99.SF04	Nut, SRF 1/4-20 USS	2
2	99.SF0408-1	Bolt, SMF 1/4-20 x 1	2
3	64.1690	Bracket, TCM	1
4	05.0135	Isolator, 1/4-20 x 1/2 x 1" F/M	2
5	06.0042-2IN	Trim, Trim Loc 1/2 x 1/16 x 2"	1
6	35.0134	Module, Tractor Control	1

ELECTRICAL

ILLUSTRATED DRAWING

Tractor Control Module (Serial # 02860-)

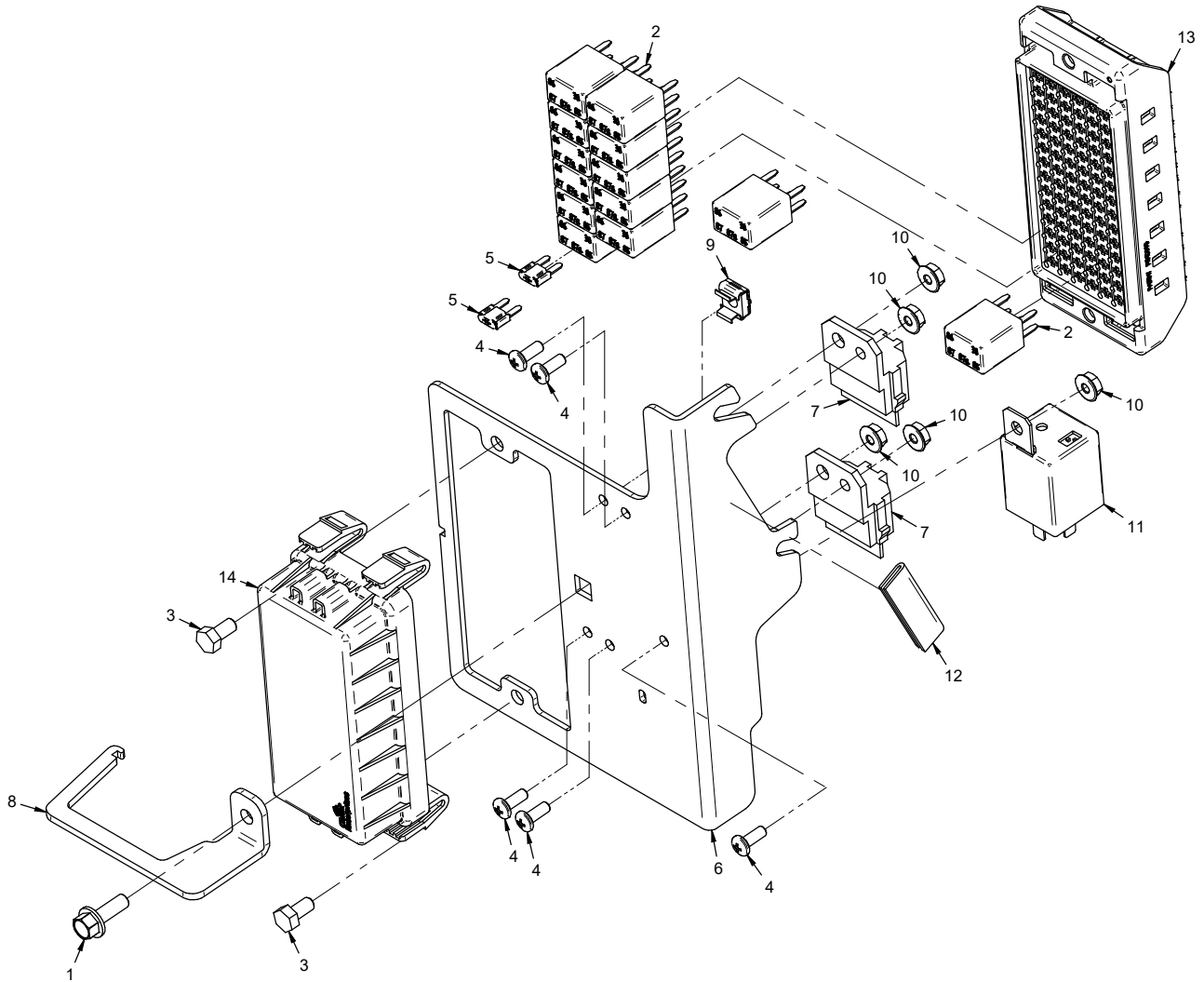

ELECTRICAL

Tractor Control Module (Serial # 02860-)

REF.	PART NO.	DESCRIPTION	QTY.
1	99.SF0406-1	Bolt, SMF 1/4-20 X 3/4.	1
2	35.0117	Relay, 12v 35/20 Amp 280 Micro.	13
3	99.M0016	Bolt, M6 X 1.00 X 12MM	2
4	99.K0062	Machine Screw, #10-32 X 1/2.	5
5	30.0563	Diode, 400V 1A.	2
6	KIN-1340	Bracket, TCS	1
7	35.0106	Time Delay, .5 Second.	2
8	KN-1394	Latch, TCS Bracket.	1
9	99.E0146	Nut, Cage 1/4-20 (.093 - .126").	1
10	99.E0035	Nut, SF #10-32	5
11	35.0163	Time Delay, Adj. 12V	1
12	06.0042-2IN	Trim, Trim Loc 1/2 x 1/16 x 2"	1
13	30.0502	Fuse Panel, 84 Pos Mini	1
14	30.0504	Cover, Fuse Panel NT2100	1

ELECTRICAL

ILLUSTRATED DRAWING

Battery, Power Cables, & Ground Cables

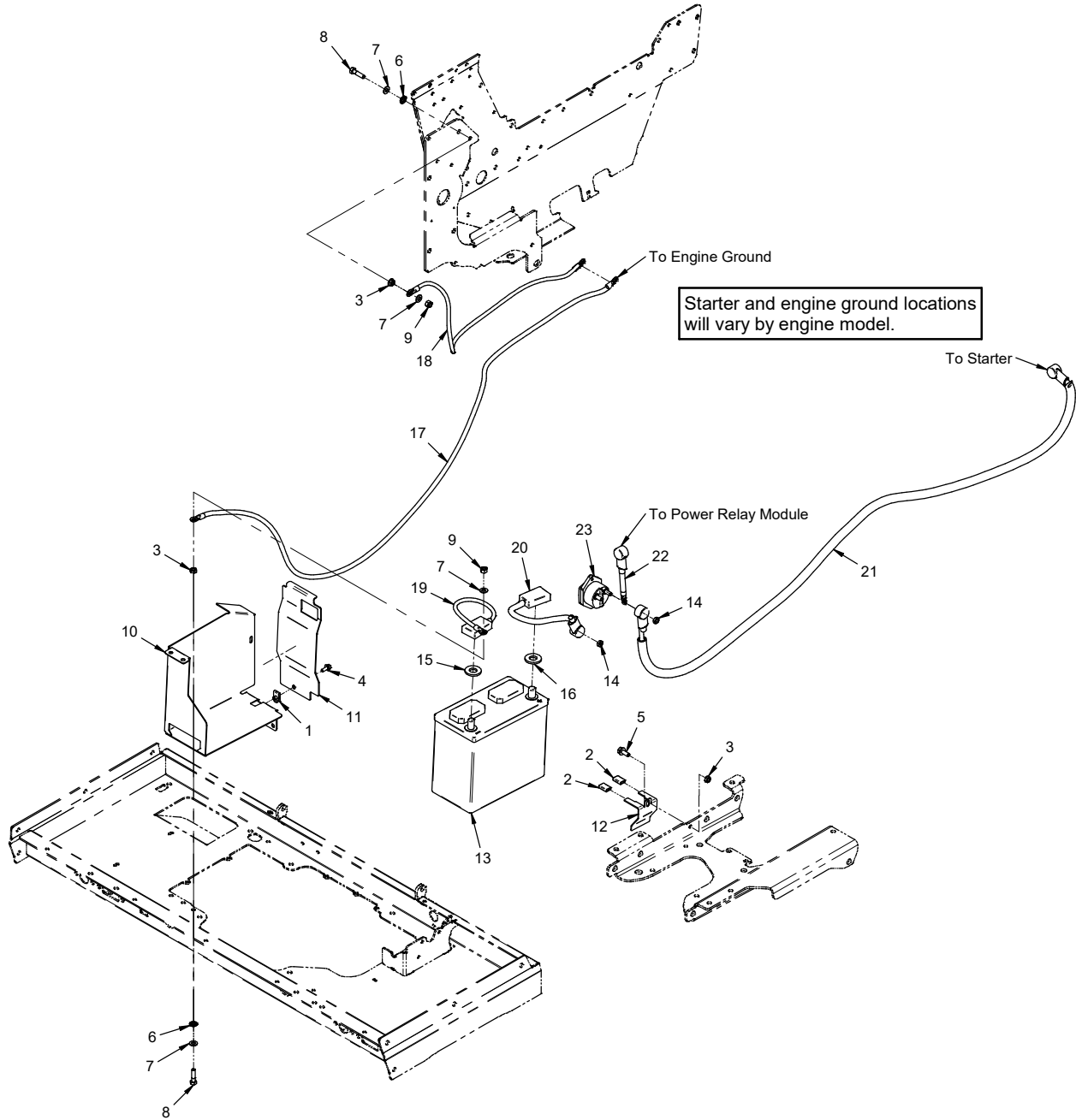

ELECTRICAL

Battery, Power Cables, & Ground Cables

REF.	PART NO.	DESCRIPTION	QTY.
1	99.E0046	Nut, "U" 1/4-20 Extruded	1
2	06.0044	Cap, Plastic 1/8 x 1/2 x 7/8	2
3	99.SF05	Nut, SRF 5/16-18 USS	3
4	99.SF0405-1	Bolt, SMF 1/4-20 X 5/8	4
5	99.SF0506-1	Bolt, SMF 5/16-18 USS X 3/4	1
6	99.G0003	Washer, Star-External 5/16	2
7	95.05	Washer, Flat 5/16 SAE	4
8	90.0510	Bolt, 5/16-18 USS x 1-1/4	2
9	99.A05N	Locknut, Nylon 5/16-18 USS	2
10	60.1116	Panel, Battery Compartment	1
11	60.1117	Panel, Foot Platform Left	1
12	64.1593	Retainer, Battery Hold Down	1
13	33.0060	Battery, Group 51R	1
14	99.E0060	Nut, Jam 5/16-18 USS	2
15	05.0122	Washer, Anti Corrosion Black	1
16	05.0121	Washer, Anti Corrosion Red	1
17	32.0103	Formed, Cable Path	1
18	32.0112	Cable, Asm Neg 4Ga	1
19	32.0101	Cable, Asm Neg 4 Ga	1
20	32.0100	Cable, Asm Pos Battery 4Ga	1
21	32.0102	Cable, Asm Pos 4Ga	1
22	32.0111	Cable, Asm Pos 6Ga (Serial # 01001-05664)	1
23	30.0338	Breaker, Circuit 150 Amp	1

ELECTRICAL

ILLUSTRATED DRAWING

Front Fuse Panel (Serial # 01001-02172)

For ordering fuses and relays, please refer to Fuse Panel Layout drawing.

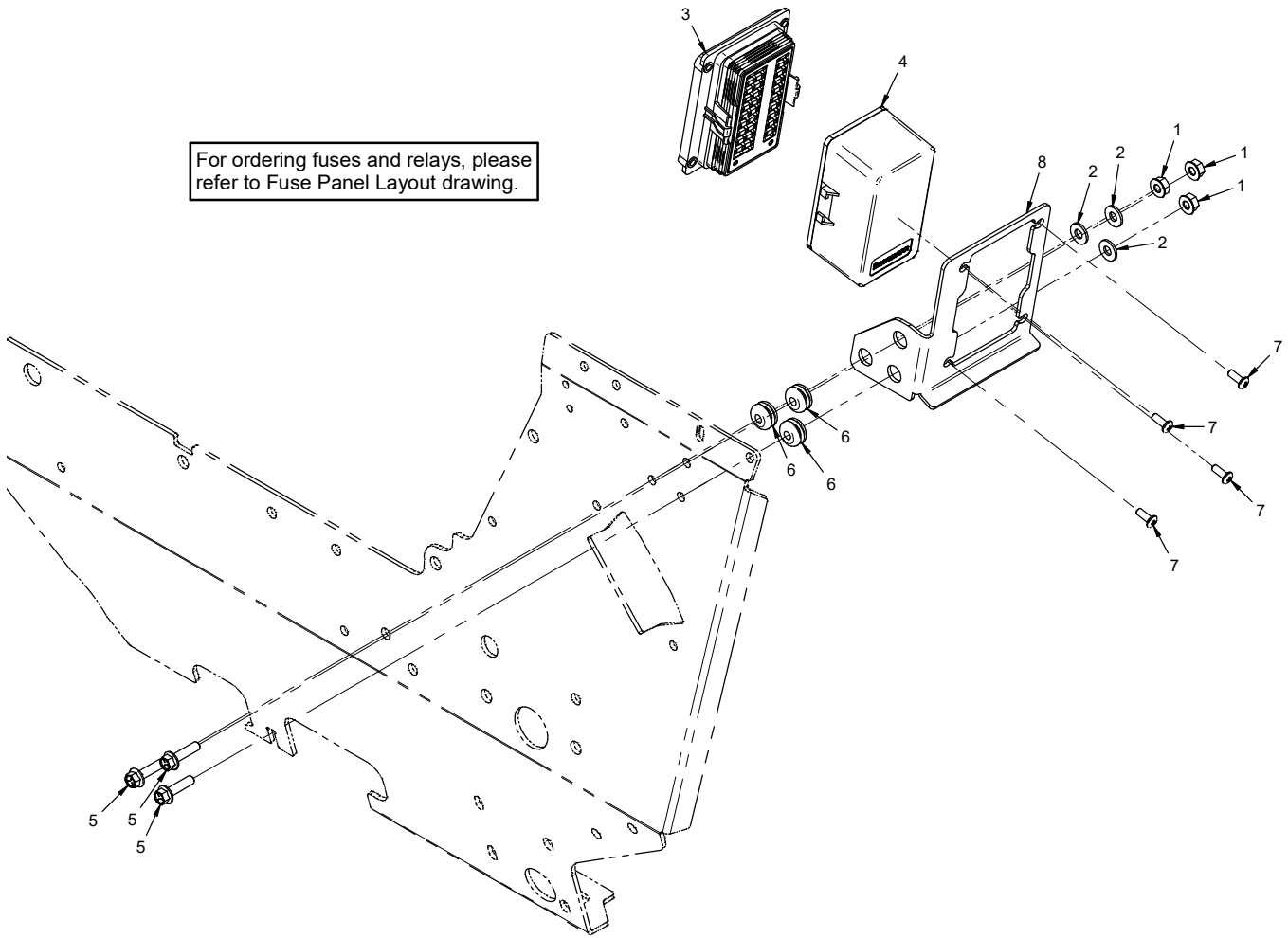

ELECTRICAL

Front Fuse Panel (Serial # 01001-02172)

REF.	PART NO.	DESCRIPTION	QTY.
1	99.E0101	Nut, Locking Flange 1/4-20	3
2	95.04	Washer, Flat 1/4 SAE	3
3	30.0356	Fuse Panel, Mini Non-Bussed	1
4	30.0331	Cover, Fuse Panel 30.0329	1
5	99.SF0408-1	Bolt, SMF 1/4-20 x 1	3
6	05.0146	Grommet, 1/4ID, 3/4OD, 7/16THK	3
7	99.K0062	Machine Screw, #10-32 X 1/2	4
8	64.1648	Bracket, Fuse Panel Mount	1

ELECTRICAL

ILLUSTRATED DRAWING Front Fuse Panel (Serial # 02173-05664)

For ordering fuses and relays, please refer to Fuse Panel Layout drawing.

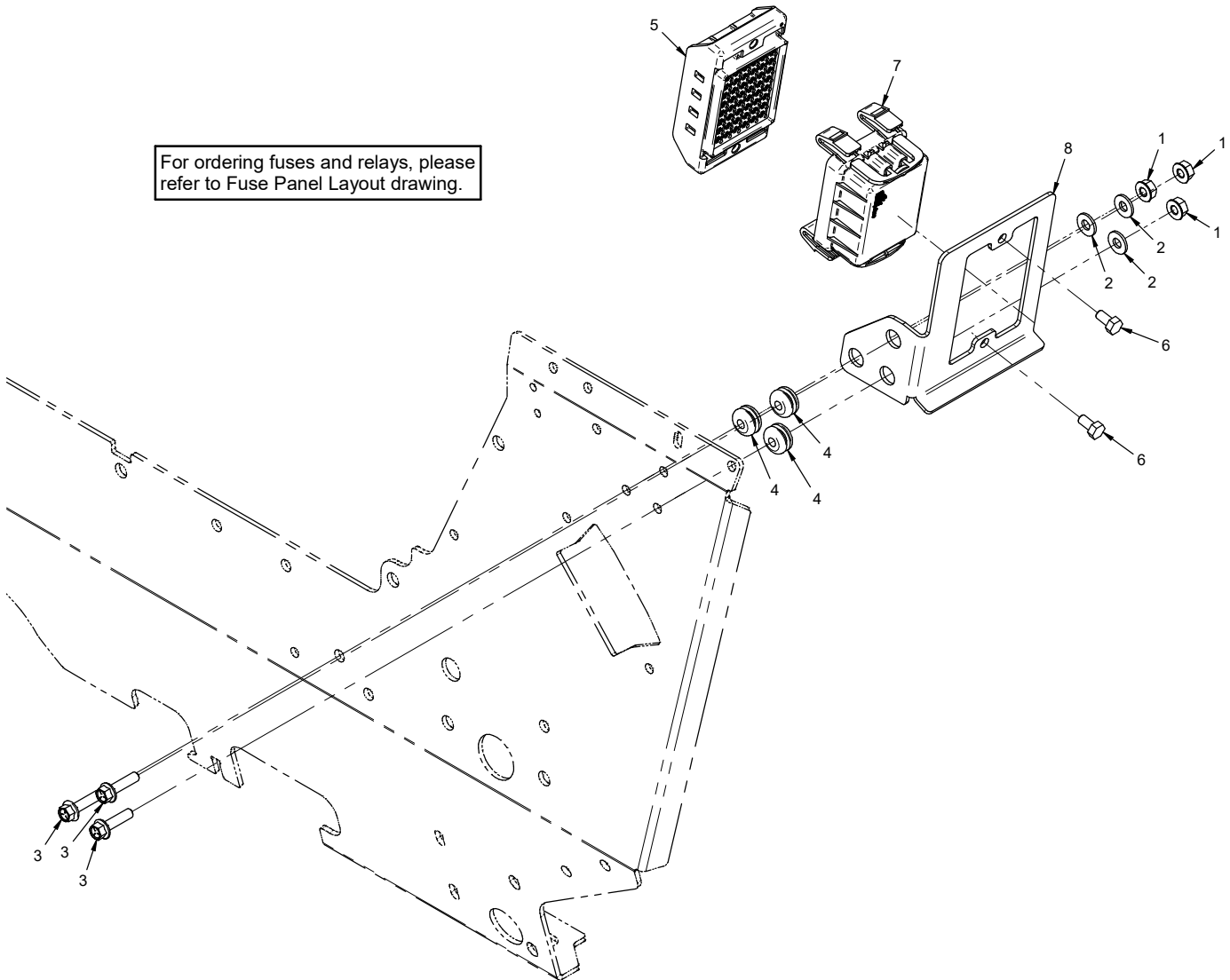

ELECTRICAL

Front Fuse Panel (Serial # 02173-05664)

REF.	PART NO.	DESCRIPTION	QTY.
1	99.E0101	Nut, Locking Flange 1/4-20	3
2	95.04	Washer, Flat 1/4 SAE	3
3	99.SF0408-1	Bolt, SMF 1/4-20 x 1	3
4	05.0146	Grommet, 1/4ID, 3/4OD, 7/16THK	3
5	30.0556	Fuse Panel, 48 Pos Mini	1
6	99.M0016	Bolt, M6 X 1.00 X 12MM	2
7	30.0557	COVER, FUSE PANEL 48 POS MINI	1
8	KN-531	Bracket, Fuse Panel Mount	1

ELECTRICAL

ILLUSTRATED DRAWING Front Fuse Panel (Serial # 05665-)

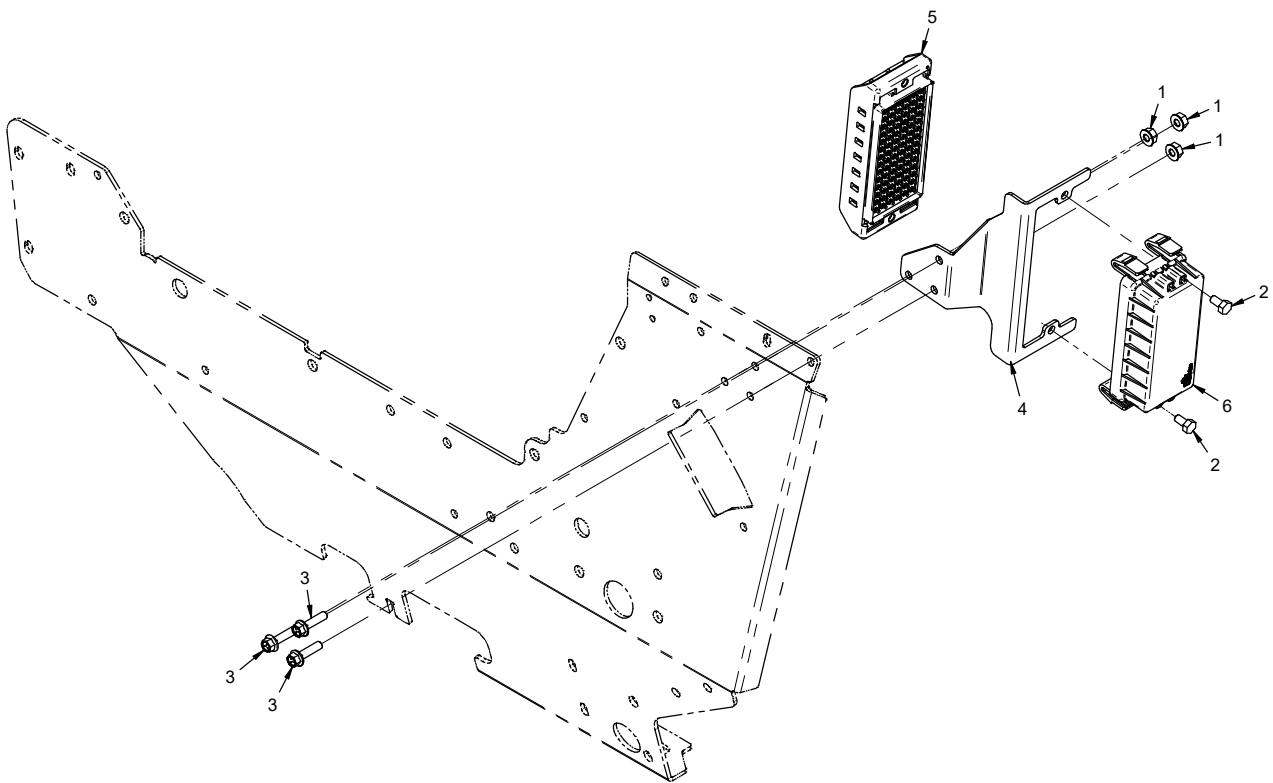

ELECTRICAL

Front Fuse Panel (Serial # 05665-)

REF.	PART NO.	DESCRIPTION	QTY.
1	99.E0101	Nut, Locking Flange 1/4-20	3
2	99.M0016	Bolt, M6 X 1.00 X 12MM	2
3	99.SF0408-1	Bolt, SMF 1/4-20 x 1	3
4	KN-1410	Bracket, Fuse Panel Mount	1
5	30.0502	Fuse Panel, 84 Pos Mini	1
6	30.0504	Cover, Fuse Panel NT2100	1

For ordering fuses and relays, please refer to Fuse Panel Layout drawing.

ELECTRICAL

ILLUSTRATED DRAWING

Rear Fuse Panel (Serial # 01001-02172)

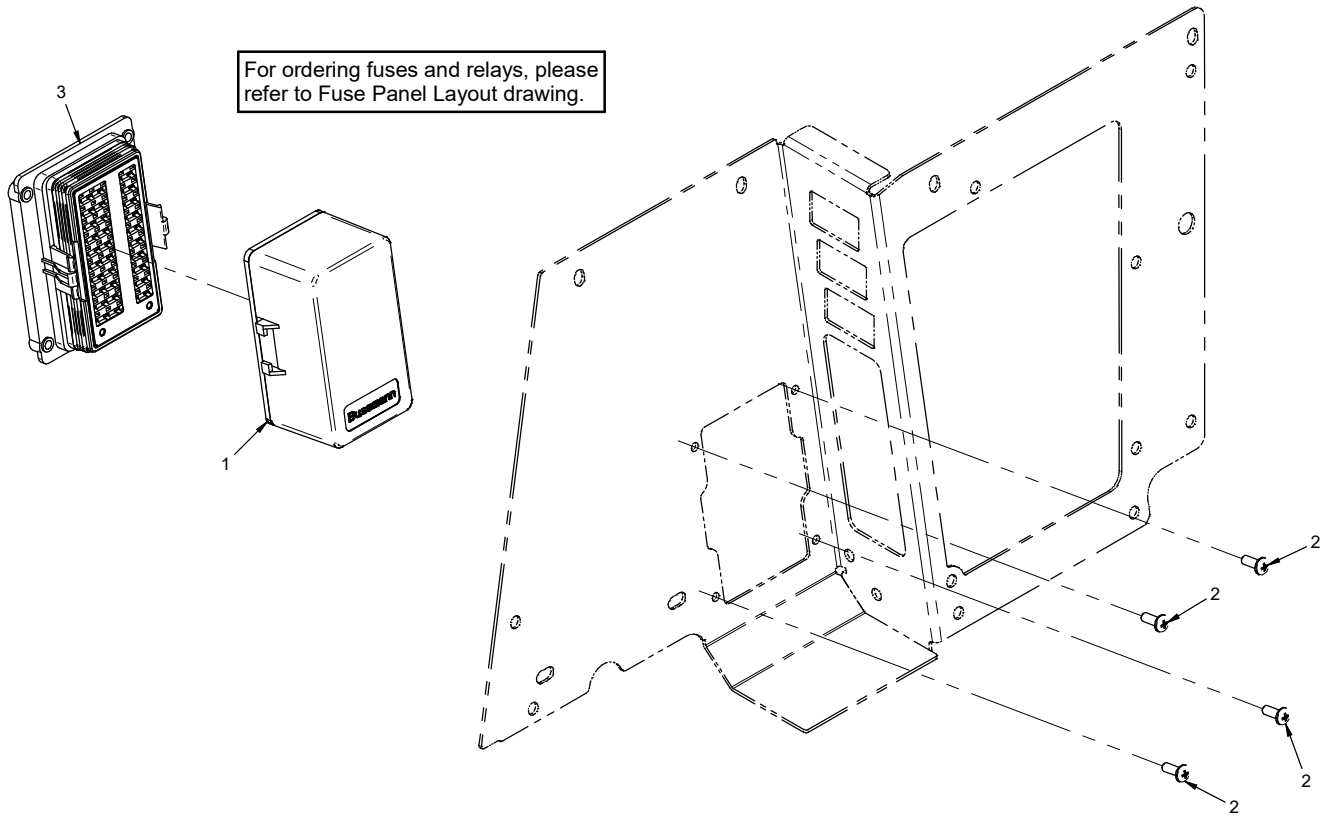

ELECTRICAL

Rear Fuse Panel (Serial # 01001-02172)

REF.	PART NO.	DESCRIPTION	QTY.
1	30.0331	Cover, Fuse Panel 30.0329	1
2	99.K0062	Machine Screw, #10-32 X 1/2	4
3	30.0356	Fuse Panel, Mini Non-Bussed	1

ELECTRICAL

ILLUSTRATED DRAWING Rear Fuse Panel (Serial # 02173-05664)

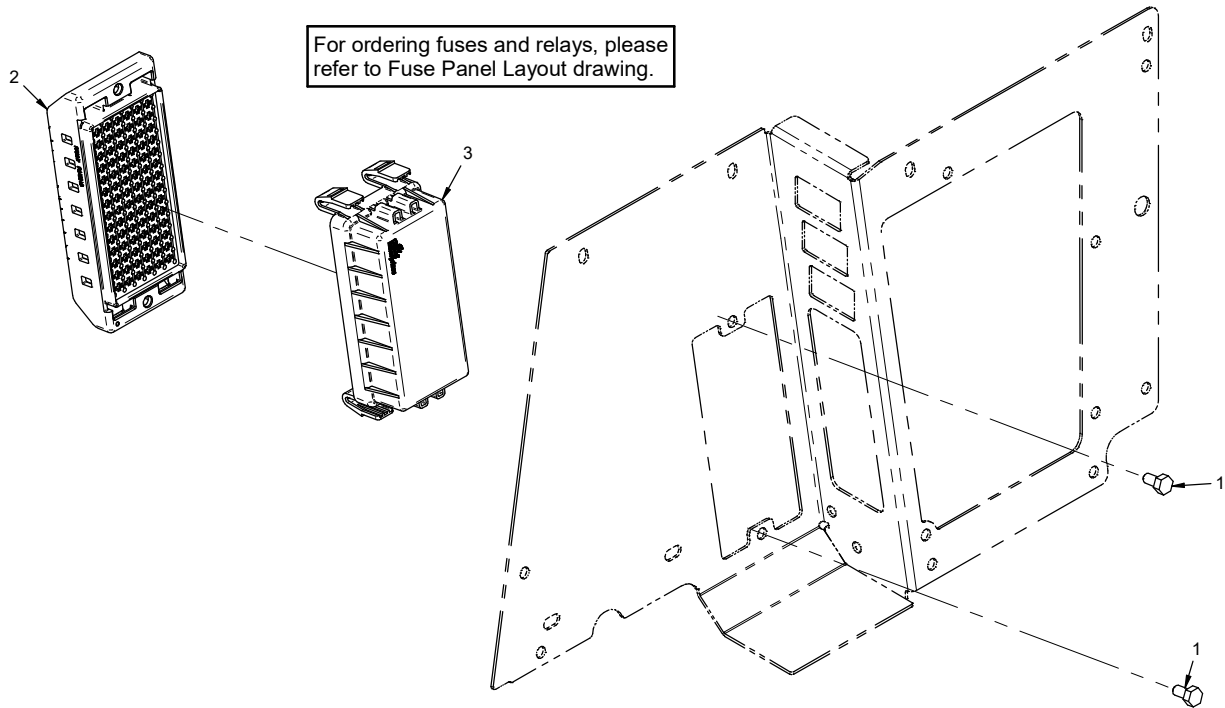

ELECTRICAL

Rear Fuse Panel (Serial # 02173-05664)

REF.	PART NO.	DESCRIPTION	QTY.
1	99.M0016	Bolt, M6 X 1.00 X 12MM	2
2	30.0502	Fuse Panel, 84 Pos Mini	1
3	30.0504	Cover, Fuse Panel NT2100	1

ELECTRICAL

ILLUSTRATED DRAWING Rear Fuse Panel (Serial # 05665-)

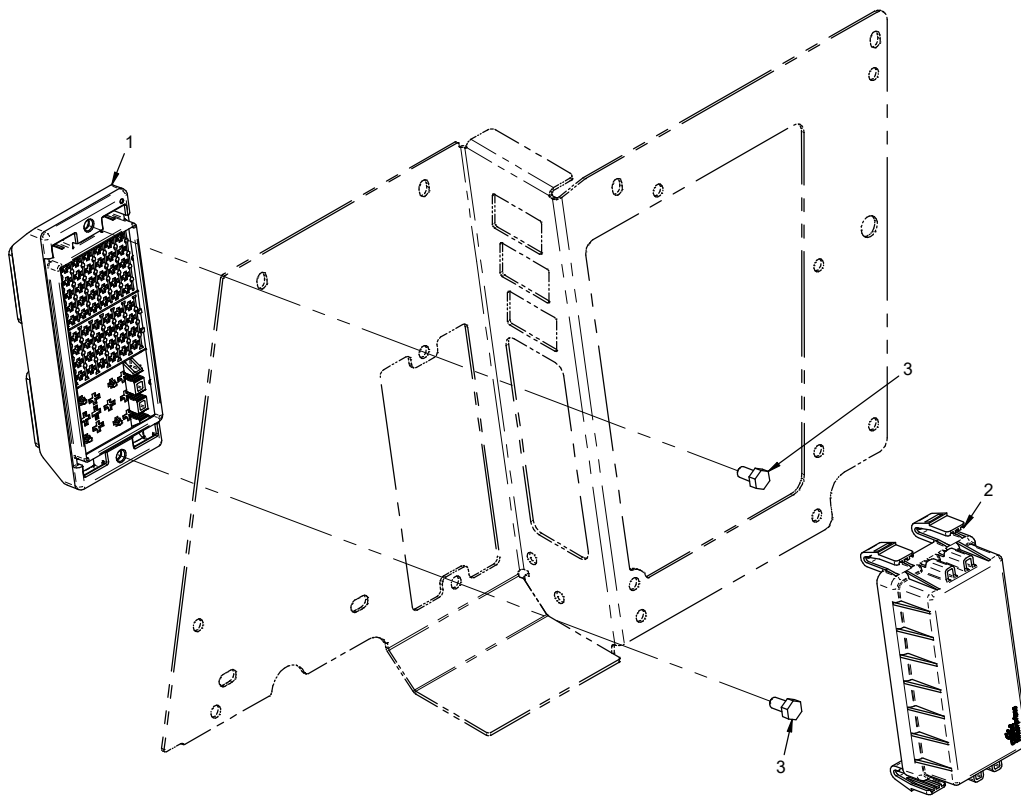

ELECTRICAL

Rear Fuse Panel (Serial # 05665-)

REF.	PART NO.	DESCRIPTION	QTY.
1	30.0596	Fuse Panel, 54 Pos Mini	1
2	30.0504	Cover, Fuse Panel NT2100	1
3	99.M0016	Bolt, M6 X 1.00 X 12MM	2

For ordering fuses and relays, please refer to Fuse Panel Layout drawing.

ELECTRICAL

ILLUSTRATED DRAWING

Power Relay Module

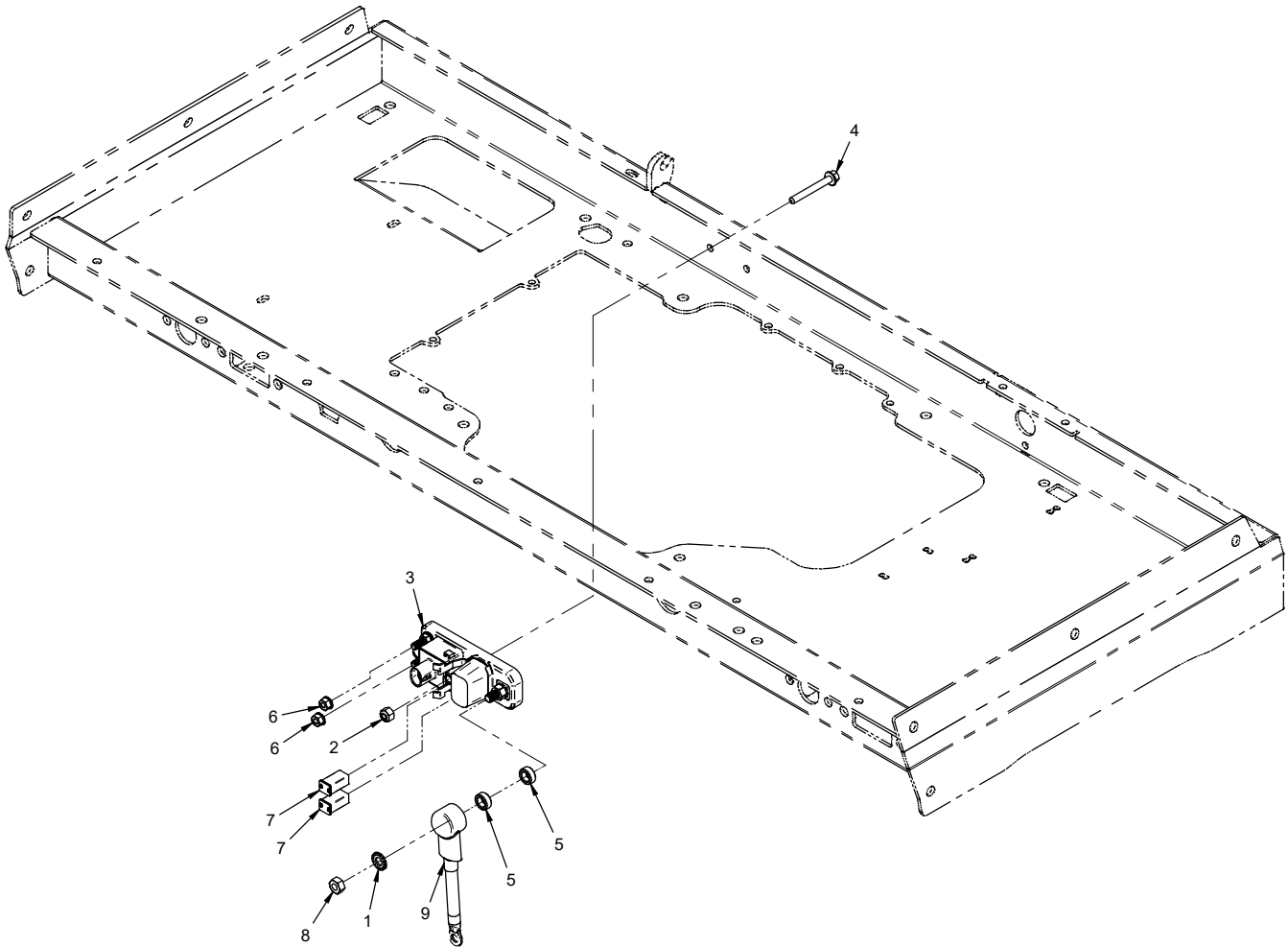

ELECTRICAL

Power Relay Module

REF.	PART NO.	DESCRIPTION	QTY.
1	99.G0003	.Washer, Star-External 5/16	1
2	99.A04N	.Locknut, Nylon 1/4-20	1
3	30.0339	.Module, Power Relay	1
4	99.SF0416-1	.Bolt, SMF 1/4-20 X 2	1
5	64.0602	.Bushing, 3/8 x 5/8 x .265	2
6	99.M0029	.Nut, M6 x 1.0 W/Lock Washer	2
7	30.0374	.Fuse, 50A J-Case Orange	2
8	99.M0008	.Nut, M8 x 1.25MM ZP	1
9	32.0111	.Cable, Asm Pos 6Ga	1

ELECTRICAL

ILLUSTRATED DRAWING

RPM Sensor

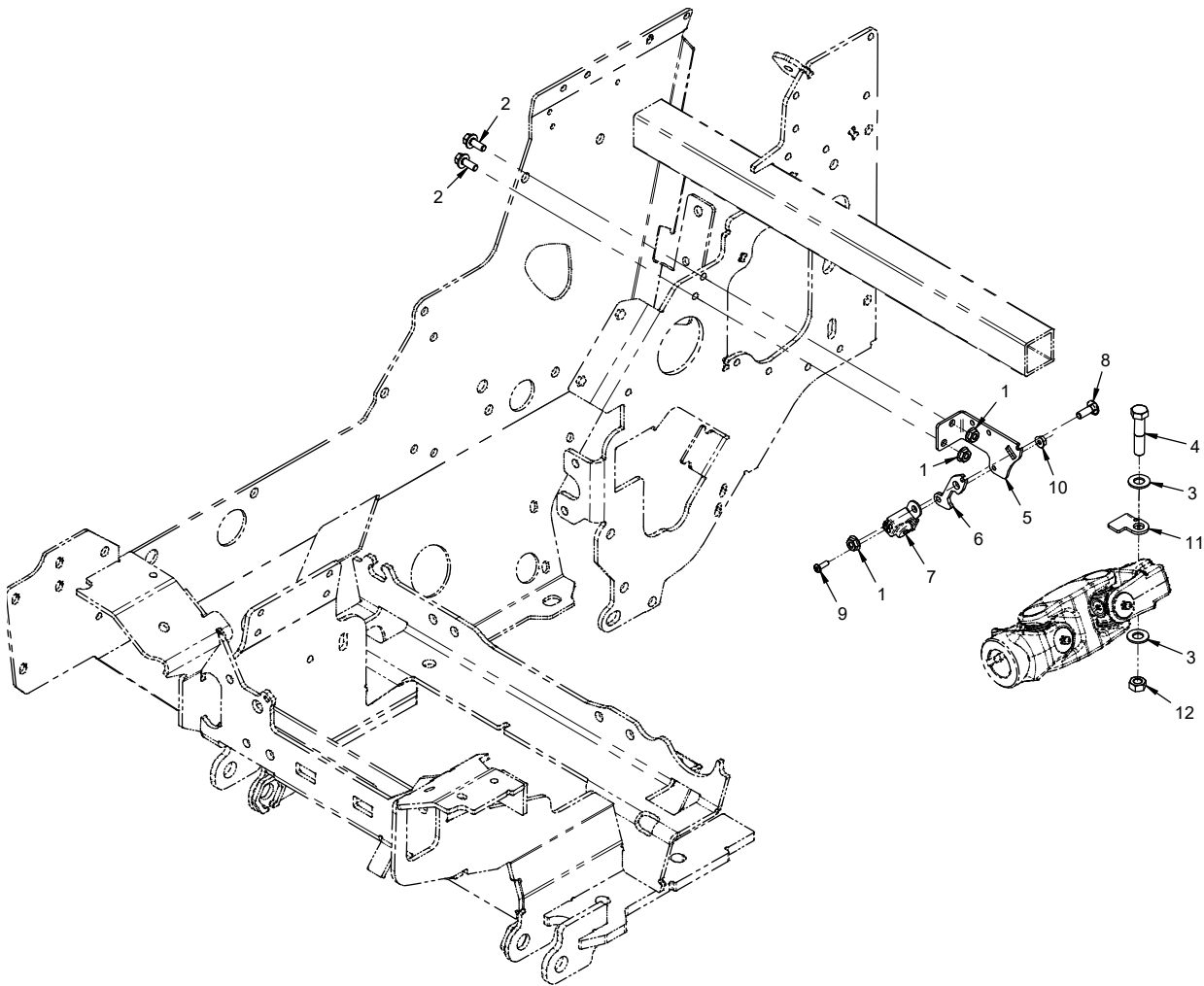

ELECTRICAL

RPM Sensor

REF.	PART NO.	DESCRIPTION	QTY.
1	99.SF04	Nut, SRF 1/4-20 USS	3
2	99.SF0405-1	Bolt, SMF 1/4-20 X 5/8	2
3	95.06	Washer, Flat 3/8 SAE	2
4	90.0614	Bolt, 3/8-16 USS x 1-3/4	1
5	64.1653	Bracket, RPM Sensor Mount	1
6	64.1655	Plate, Tach RPM Sensor Spacer	1
7	13.0162	Trigger, Ignition	1
8	97.0406	Bolt, Carriage 1/4-20 x 3/4	1
9	99.K0041	Machine Screw, #8-32 X 1/2	1
10	99.E0062	Nut, SRF #8-32	1
11	64.1654	Plate, Driveshaft Tach Trigger	1
12	99.A06	Locknut, Stover 3/8-16 USS	1

ELECTRICAL

ILLUSTRATED DRAWING

Speedometer Sensor (Serial # 01001-02652)

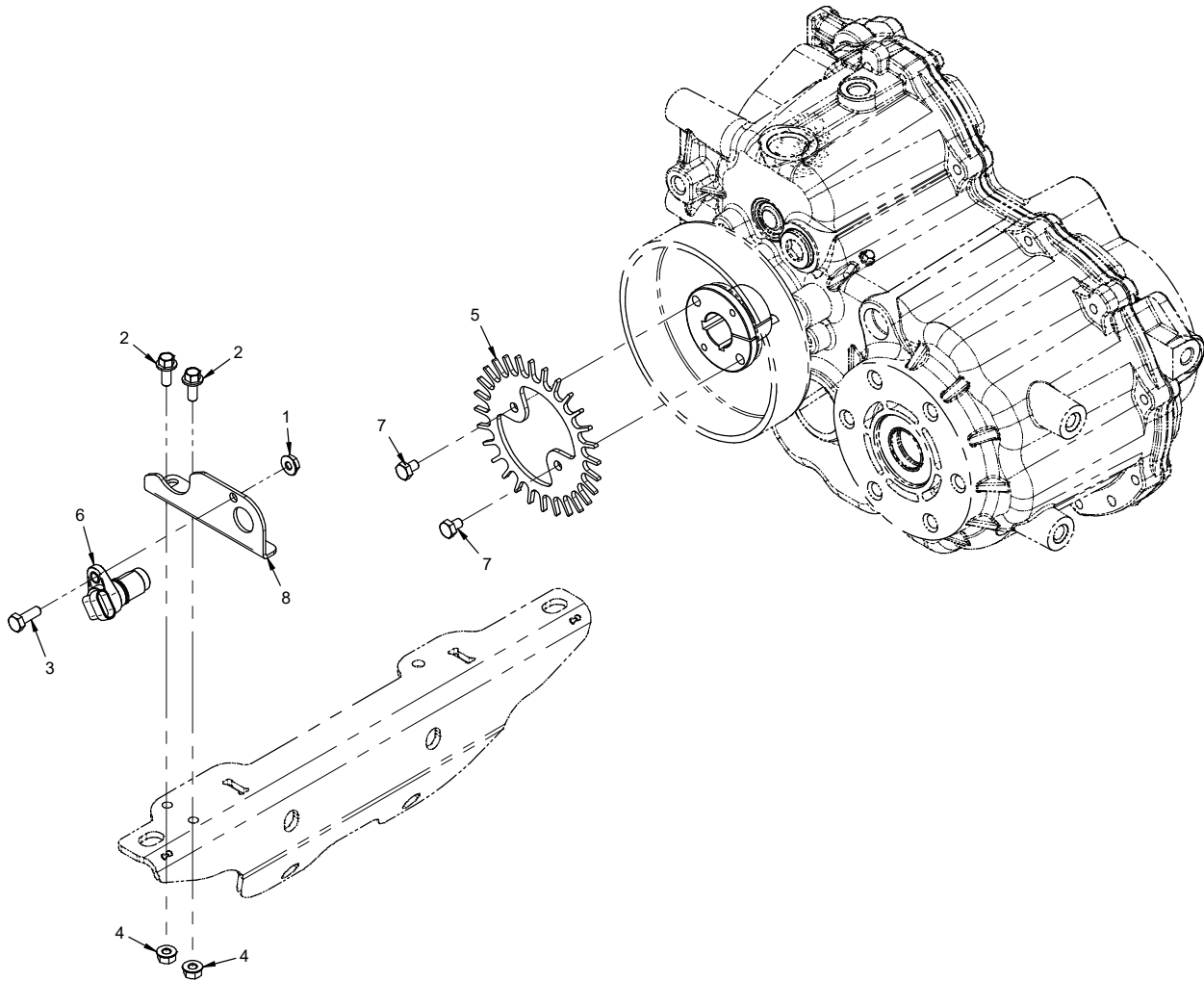

ELECTRICAL

Speedometer Sensor (Serial # 01001-02652)

REF.	PART NO.	DESCRIPTION	QTY.
1	99.SF04	Nut, SRF 1/4-20 USS	1
2	99.SF0405-1	Bolt, SMF 1/4-20 X 5/8	2
3	90.0406	Bolt, 1/4-20 USS x 3/4"	1
4	99.E0101	Nut, Locking Flange 1/4-20	2
5	64.1606	Plate, Speed Indicator	1
6	35.0121	Sensor, Gear Tooth Speed	1
7	90.0403	Bolt, 1/4-20 USS X 3/8	2
8	64.1604	Bracket, Speed Sensor Mount	1

ELECTRICAL

ILLUSTRATED DRAWING Speedometer Sensor (Serial # 02653-03443)

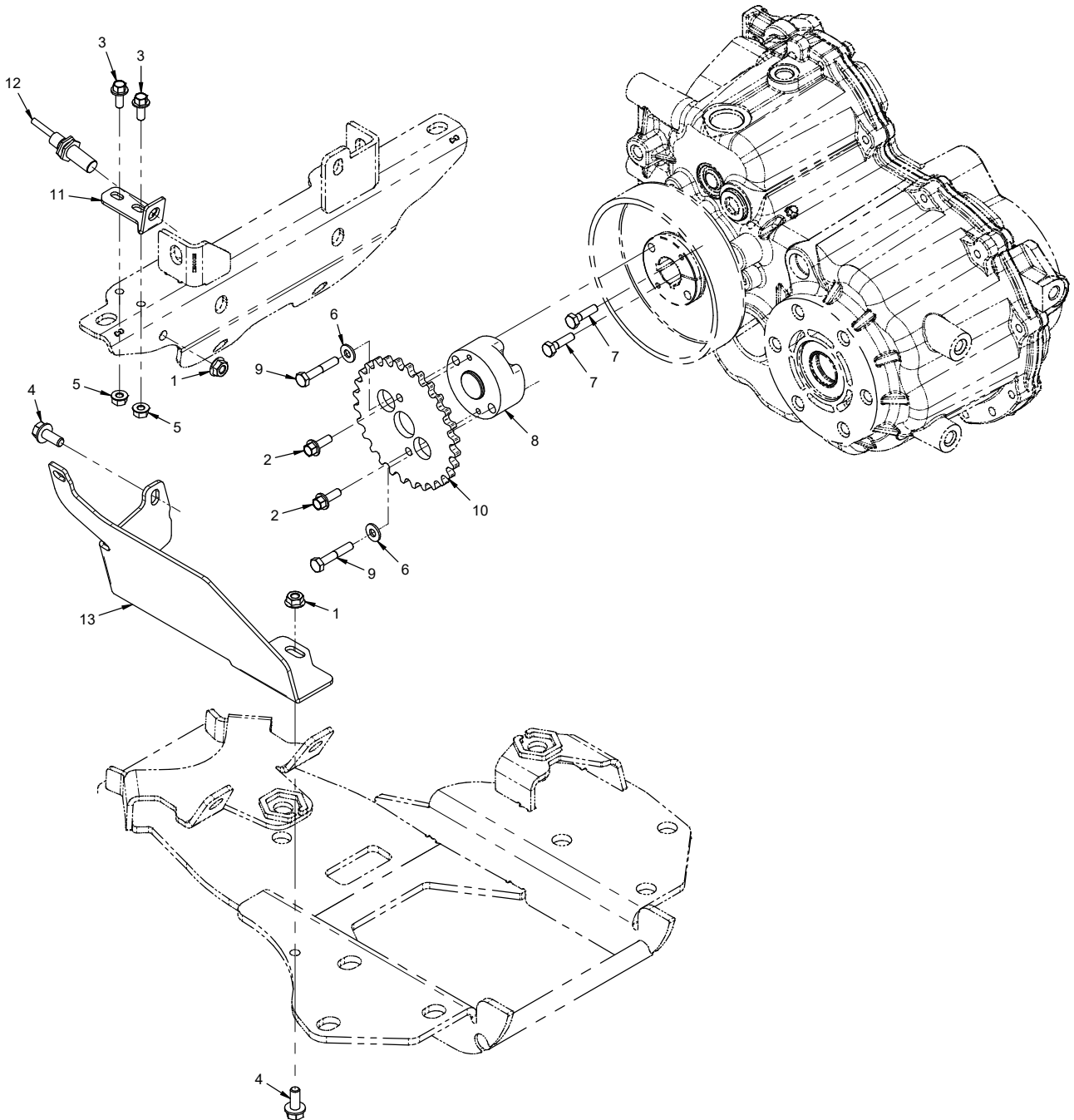

ELECTRICAL

Speedometer Sensor (Serial # 02653-03443)

REF.	PART NO.	DESCRIPTION	QTY.
1	99.SF05	.Nut, SRF 5/16-18 USS	2
2	99.SF0406-1	.Bolt, SMF 1/4-20 X 3/4.	2
3	99.SF0405-1	.Bolt, SMF 1/4-20 X 5/8.	2
4	99.SF0506-1	.Bolt, SMF 5/16-18 USS x 3/4.	2
5	99.E0101	.Nut, Locking Flange 1/4-20	2
6	95.04	.Washer, Flat 1/4 SAE	2
7	90.0408	.Bolt, 1/4-20 USS x 1	2
8	KN-1417	.Spacer, Speed Sensor Gear	1
9	90.0412	.Bolt, 1/4-20 USS x 1-1/2	2
10	KN-1414	.Plate, Speed Indicator, Radial Sensor Mt.	1
11	KN-1413	.Mount, Speed Sensor	1
12	35.0164-1	.Sensor, Gear Tooth Speed	1
13	KN-1415	.Guard, Speed Sensor Gear	1

ELECTRICAL

ILLUSTRATED DRAWING Speedometer Sensor (Serial # 03444-)

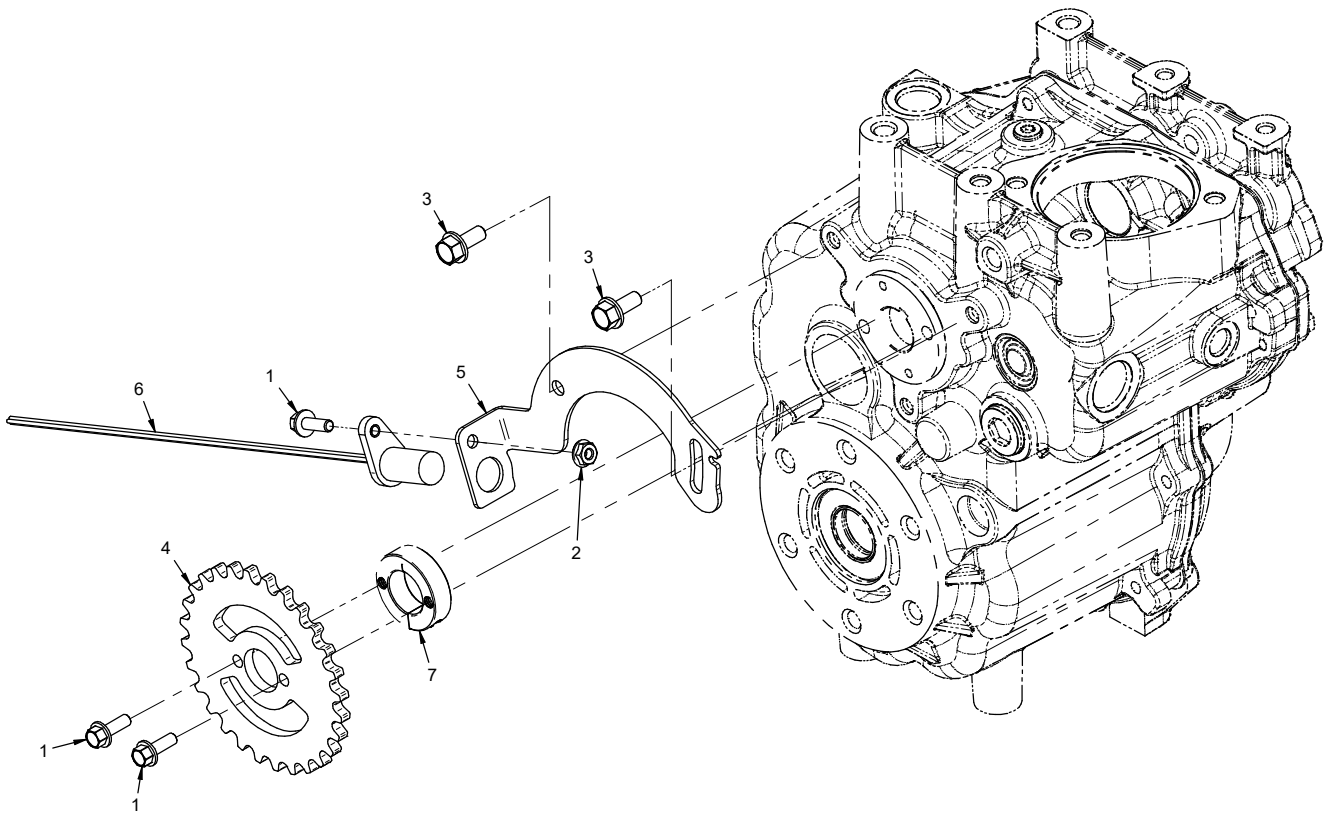

ELECTRICAL

Speedometer Sensor (Serial # 03444-)

REF.	PART NO.	DESCRIPTION	QTY.
1	99.SF0406-1	Bolt, SMF 1/4-20 X 3/4.	3
2	99.SF04	Nut, SRF 1/4-20 USS	1
3	99.SF0506-1	Bolt, SMF 5/16-18 USS x 3/4.	2
4	KN-1426	Plate, Speed Indicator, Rear Mount	1
5	KN-1424	Mount, Speed Sensor	1
6	35.0166-2	Sensor, Gear Tooth Speed	1
7	85.SC16F	Shaft Collar, 1" w/ Face Mount	1

HYDRAULICS, AXLES, & WHEELS

ILLUSTRATED DRAWING

Hydraulic Diagram

ALL VIEWS ARE FROM REAR OF TRACTOR, OR AS NOTED

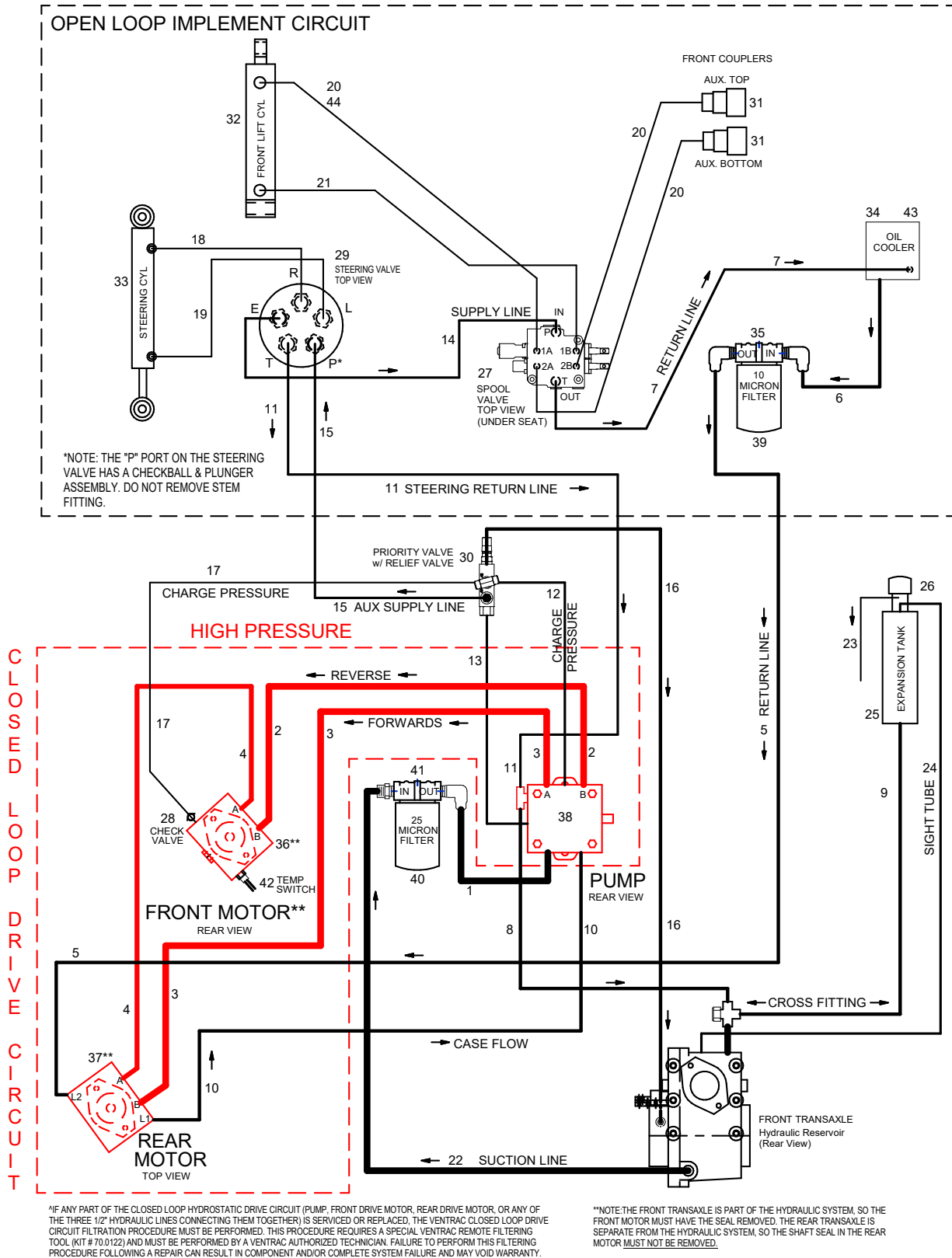

*IF ANY PART OF THE CLOSED LOOP HYDROSTATIC DRIVE CIRCUIT (PUMP, FRONT DRIVE MOTOR, REAR DRIVE MOTOR, OR ANY OF THE THREE 1/2" HYDRAULIC LINES CONNECTING THEM TOGETHER) IS SERVICED OR REPLACED, THE VENTRAC CLOSED LOOP DRIVE CIRCUIT FILTRATION PROCEDURE MUST BE PERFORMED. THIS PROCEDURE REQUIRES A SPECIAL VENTRAC REMOTE FILTERING TOOL (KIT # 70.0122) AND MUST BE PERFORMED BY A VENTRAC AUTHORIZED TECHNICIAN. FAILURE TO PERFORM THIS FILTERING PROCEDURE FOLLOWING A REPAIR CAN RESULT IN COMPONENT AND/OR COMPLETE SYSTEM FAILURE AND MAY VOID WARRANTY.

**NOTE: THE FRONT TRANSAXLE IS PART OF THE HYDRAULIC SYSTEM, SO THE FRONT MOTOR MUST HAVE THE SEAL REMOVED. THE REAR TRANSAXLE IS SEPARATE FROM THE HYDRAULIC SYSTEM, SO THE SHAFT SEAL IN THE REAR MOTOR MUST NOT BE REMOVED.

HYDRAULICS, AXLES, & WHEELS

Hydraulic Diagram

REF.	PART NO.	DESCRIPTION	QTY.
1	22.0088	Hose, 3/4x16.00 SAE 100R4ExFlex	1
2	20.0406	Hose, 3/4x20.00 SS Braid PTFE	1
3	20.0405	Hose, 3/4x75.50 SS Braid PTFE	1
4	20.0414	Hose, 5/8 x 53.00 SAE 100R16	1
5	22.0085	Hose, 1/2x15.00 ASTM D380 / ASTM D6751	1
6	22.0084	Hose, 1/2x14.50 ASTM D380 / ASTM D6751	1
7	22.0082	Hose, 1/2x32.00 ASTM D380 / ASTM D6751	1
8	22.0081	Hose, 1/2x29.00 ASTM D380 / ASTM D6751	1
9	22.0080	Hose, 1/2x15.00 ASTM D380 / ASTM D6751	1
10	22.0079	Hose, 1/2x49.00 ASTM D380 / ASTM D6751	1
11	22.0090	Hose, 3/8x9.50 ASTM D380 / ASTM D6751	1
12	22.0086	Hose, 3/8x21.00 ASTM D380 / ASTM D6751	1
13	20.0396	Hose, 3/8x19.00 SAE 100R17AR	1
14	20.0395	Hose, 3/8x56.50 SAE 100R17AR	1
15	20.0394	Hose, 3/8x18.50 SAE 100R17AR	1
16	22.0091	Hose, 1/4x14.50 ASTM 380 / ASTM D6751 (Serial # 01001-02391)	1
16	20.0419	Hose, 3/8x26.00 SAE 100R17AR (Serial # 02392-)	1
17	22.0089	Hose, 1/4x12.50 ASTM D380 / ASTM D6751	1
18	20.0402	Hose, 1/4x36.00 SAE 100R17AR	1
19	20.0401	Hose, 1/4x43.00 SAE 100R17AR	1
20	20.0398	Hose, 1/4x58.00 SAE 100R17AR (Serial # 01001-05059)	3
20	20.0398	Hose, 3/8x58.00 SAE 100R17AR (Serial # 05060-)	2
21	20.0397	Hose, 1/4x48.00 SAE 100R17AR (Serial # 01001-05059)	1
21	20.0424	Hose, 3/8x48.00 SAE 100R17AR (Serial # 05060-)	1
22	20.0403	Steel Tube, 3/4" OD x .065 Wall	1
23	27.F04	Hose, Fuel Line x 1/4 /ft	1
24	27.T06-3	Tube, Silicon 3/8" ID	1
25	KN-6052	Tank, Steel Hydraulic 4520	1
26	29.0126	Fitting, Cap 1" FP	1
27	23.0201	Valve, 2 Spool W/LH Flt, RH SP	1
28	23.0200	Valve, Check Parker 5 PSI, 06 ORB	1
29	23.0199	Valve, Steering	1
30	23.0198	Valve Block, Priority/Relief	1
31	23.0197	Coupler, Hyd Quick Female 1/4 ORB	2
32	23.0156	Cylinder, 2-1/4" x 7" Lift	1
33	23.0145	Cylinder, 1-3/4" x 8 Steering	1
34	21.0155	Cooler, Hydraulic	1
35	21.0154	Filter, Head 08 ORB	1
36	21.0149	Motor, Hyd. Danfoss 20cc/Rev	1
37	21.0149	Motor, Hyd. Danfoss 20cc/Rev	1
38	21.0148	Pump, Hyd. Danfoss 20cc	1
39	21.0124	Filter, Hyd. 10 Micron Cel.	1
40	21.0122	Filter, Hyd. 25 Micron Syn.	1
41	21.0119	Filter, Head -10 ORB Ports	1
42	13.0341	Switch, Temp -06 SAE ORB	1
43	13.0239	Switch, Temperature 170 F	1
44	20.0425	Hose, 3/8x58.00 SAE 100R17AR (Serial # 05060-)	1

HYDRAULICS, AXLES, & WHEELS

Hydraulic Fitting O-Ring Chart

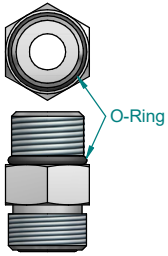

Straight Thread O-Ring Boss - O-Ring Replacement Part Numbers						
SAE Fitting Size	Thread Size	VPI Part #	ID	OD	Width	AS568A Dash #
-04	7/16-20	26.0035	0.351"	0.495"	0.072"	904
-06	9/16-18	26.0036	0.468"	0.624"	0.078"	906
-08	3/4-16	26.0037	0.644"	0.818"	0.087"	908
-10	7/8-14	26.0038	0.755"	0.949"	0.097"	910
-12	1-1/16-12	26.0039	0.924"	1.156"	0.116"	912
-16	1-5/16-12	26.0043	1.171"	1.403"	0.116"	916

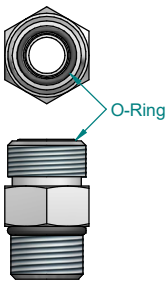

O-Ring Face Seal Hose - O-Ring Replacement Part Numbers						
SAE Fitting Size	Thread Size	VPI Part #	ID	OD	Width	AS568A Dash #
-04	9/16-18	26.0044	0.301"	0.441"	0.070"	011
-06	11/16-16	26.0025	0.364"	0.504"	0.070"	012
-08	13/16-16	26.0009	0.489"	0.629"	0.070"	014
-10	1-14	26.0023	0.614"	0.754"	0.070"	016
-12	1-3/16-12	26.0045	0.739"	0.879"	0.070"	018
-16	1-7/16-12	26.0046	0.926"	1.066"	0.070"	021

HYDRAULICS, AXLES, & WHEELS

Blank Page

HYDRAULICS, AXLES, & WHEELS

ILLUSTRATED DRAWING

Hydraulic Oil Tank

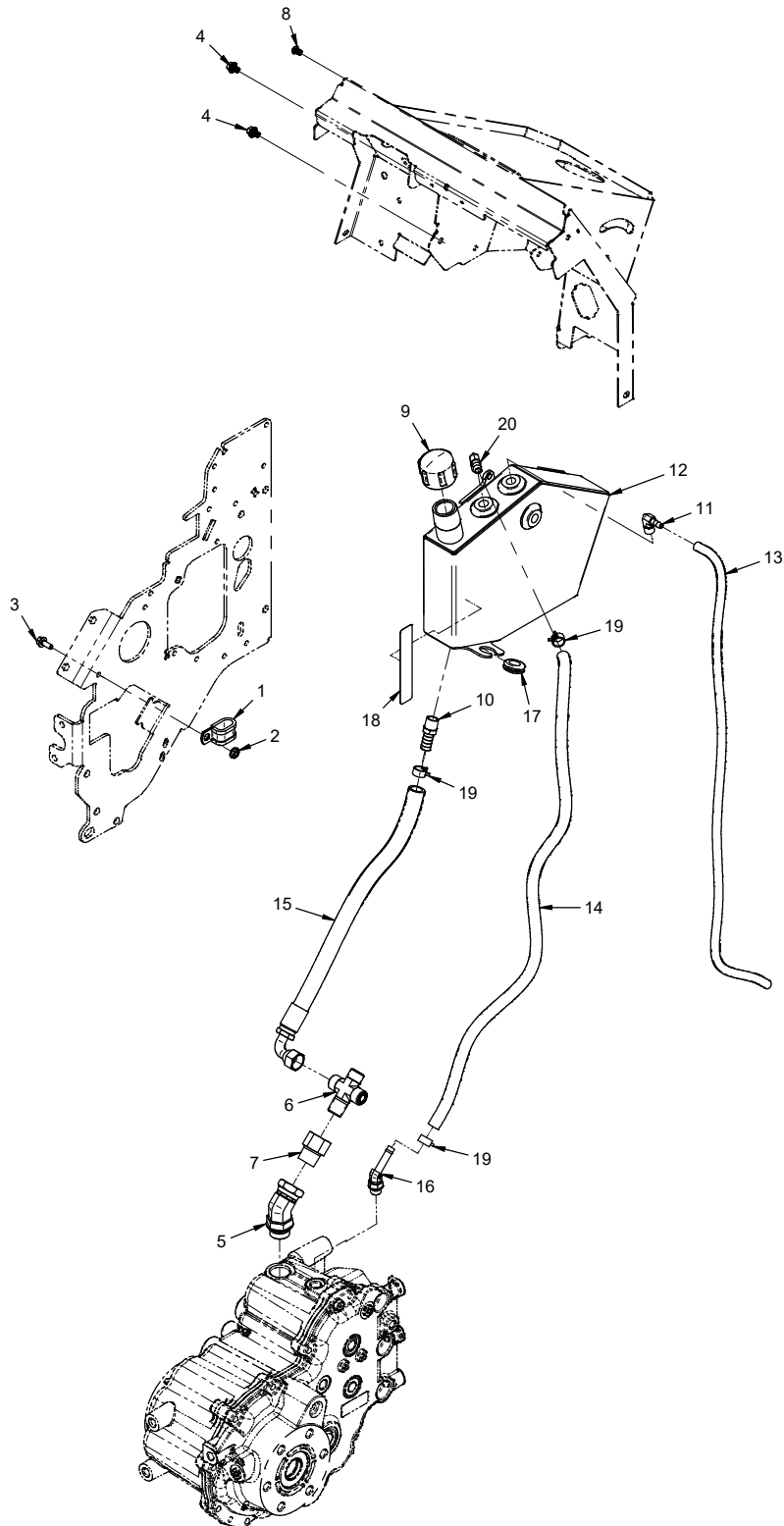

HYDRAULICS, AXLES, & WHEELS

Hydraulic Oil Tank

REF.	PART NO.	DESCRIPTION	QTY.
1	11.0046	Clamp, Cushioned 1/2" 2-Tube	1
2	99.SF04	Nut, SRF 1/4-20 USS	1
3	99.SF0405-1	Bolt, SMF 1/4-20 X 5/8	1
4	99.SF0403	Bolt, SRF 1/4-20 X 3/8	2
5	25.6902-12-12	Fitting, 45 MFE 3/4 x 3/4	1
6	25.FF2651MP-08-08-08-08	Fitting, Cross 08FF	1
7	25.5405-12-08	Fitting, Reducer 3/4 X 1/2	1
8	99.0403	Bolt, 1/4-20 X 3/8 BSCS	1
9	29.0126	Fitting, Cap 1" FP	1
10	29.BF08MP06	Fitting, 1/2 Barb x 3/8 MP St	1
11	29.BF04MP0490	Fitting, 1/4 Barb x 1/4 MP 90	1
12	KN-6052	Tank, Steel Hydraulic 4520	1
13	27.F04-30IN	Hose, Fuel Line x 1/4 x 30"	1
14	27.T06-3-32IN	Tube, Silicon 3/8" ID	1
15	22.0080	Hose, 1/2x15.00 ASTM D380 / ASTM D6751	1
16	25.4603-06-06	Fitting, 45 ME 06 HB x 06 MAORB	1
17	05.0140	Grommet, 5/8 ID, 1-1/8 OD, 3/8T	1
18	00.0340	Decal, Hydraulic Oil	1
19	11.0048	Clamp, Hose Band 9/16" OD Hose	3
20	29.BF06MP0490	Fitting, 3/8 Barb x 1/4 MP 90	1

HYDRAULICS, AXLES, & WHEELS

ILLUSTRATED DRAWING Hydraulic Steering System

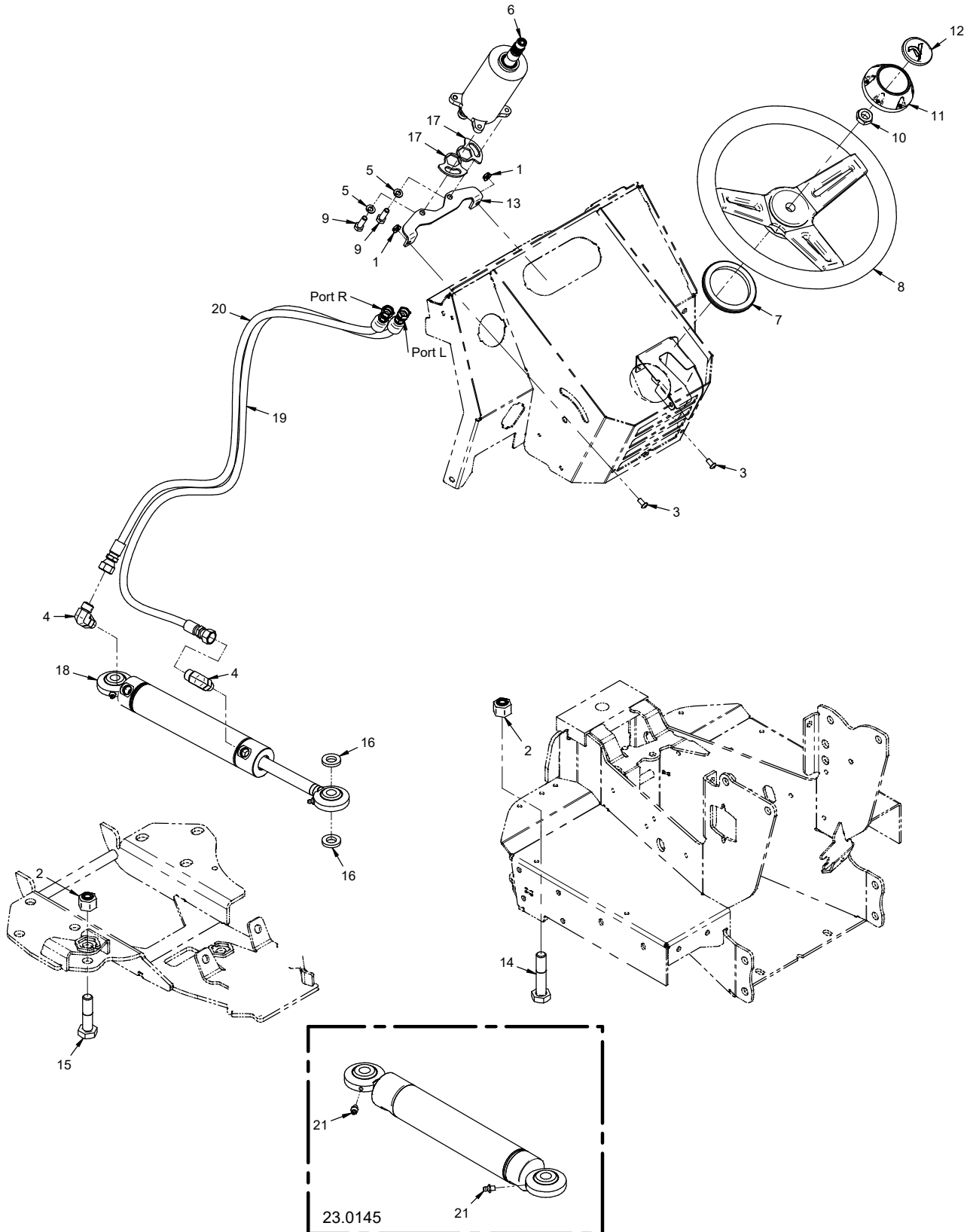

HYDRAULICS, AXLES, & WHEELS

Hydraulic Steering System

REF.	PART NO.	DESCRIPTION	QTY.
1	99.SF04	Nut, SRF 1/4-20 USS	2
2	99.E0095	Locknut, 5/8-11 Heavy Nylon	2
3	99.0404	Bolt, 1/4-20 x 1/2 BSCS	2
4	25.FF6801-06-06	Fitting, 90 Elbow - 6MFF X 6MB	2
5	96.05	Washer, Lock 5/16	2
6	23.0199	Valve, Steering	1
7	05.0080	Grommet, 2-3/4 ID, 3-5/8 OD, 5/16T	1
8	47.0117	Steering Wheel, 16mm X 40T	1
9	99.M0009	Bolt, M8 X 1.25 P X 25MM	2
10	99.E0011	Nut, Jam 5/8-18 SAE	1
11	47.0118	Cap, Steering Wheel	1
12	64.1623	Plate, Fitting Lock	2
13	00.0207	Decal, Ventrac Dome	1
14	KN-1055	Bracket, Steering Valve MT	1
15	99.K0132	Bolt, 5/8-11 X 3 Grd A325	1
16	99.K0112	Bolt, 5/8-11 X 2-1/2 Grd A325	1
17	KN-1246	Spacer, Steering Cylinder	2
18	23.0145	Cylinder, 1-3/4" X 8 Steering	1
19	20.0401	Hose, 1/4x43.00 SAE 100R17AR	1
20	20.0402	Hose, 1/4x36.00 SAE 100R17AR	1
21	29.GF0001	Grease Ftg, 1/4 SAE St.	2

HYDRAULICS, AXLES, & WHEELS

Front Hitch Hydraulic Lift

REF.	PART NO.	DESCRIPTION	QTY.
1	99.E0103	Nut, Locking Flange 1/2-13	1
2	95.08	Washer, Flat 1/2 SAE	2
3	64.1712	Bushing, Steel .516 x 1.000	1
4	64.1631	Bushing, Lift Cylinder Rear	1
5	90.0820	Bolt, 1/2-13 USS x 2-1/2	1
6	99.SF0836-1	BOLT, SMF 1/2-13 X 4-1/2	1
7	99.A08C	Locknut, Center 1/2-13	1
8	25.FF6801-06-06	Fitting, 90 Elbow - 6MFF X 6MB	2
9	25.FF6400-06-06	Fitting, Connector -06MFF x -06MB	2
10	23.0201	Valve, 2 Spool W/LH Flt, RH SP (See Hydraulics, Axles, & Wheels Section for details)	1
11	23.0156	Cylinder, 2-1/4" x 7" Lift	1
12	20.0397	Hose, 1/4x48.00 SAE 100R17AR (Serial # 01001 - 05059)	1
12	20.0424	Hose, 3/8x48.00 SAE 100R17AR (Serial # 05060 -)	1
13	20.0398	Hose, 1/4x58.00 SAE 100R17AR (Serial # 01001 - 05059)	1
13	20.0425	Hose, 3/8x58.00 SAE 100R17AR (Serial # 05060 -)	1
21	29.GF0001	Grease Ftg, 1/4 SAE ST	2

HYDRAULICS, AXLES, & WHEELS

ILLUSTRATED DRAWING

Auxiliary Hydraulic Quick Couplers

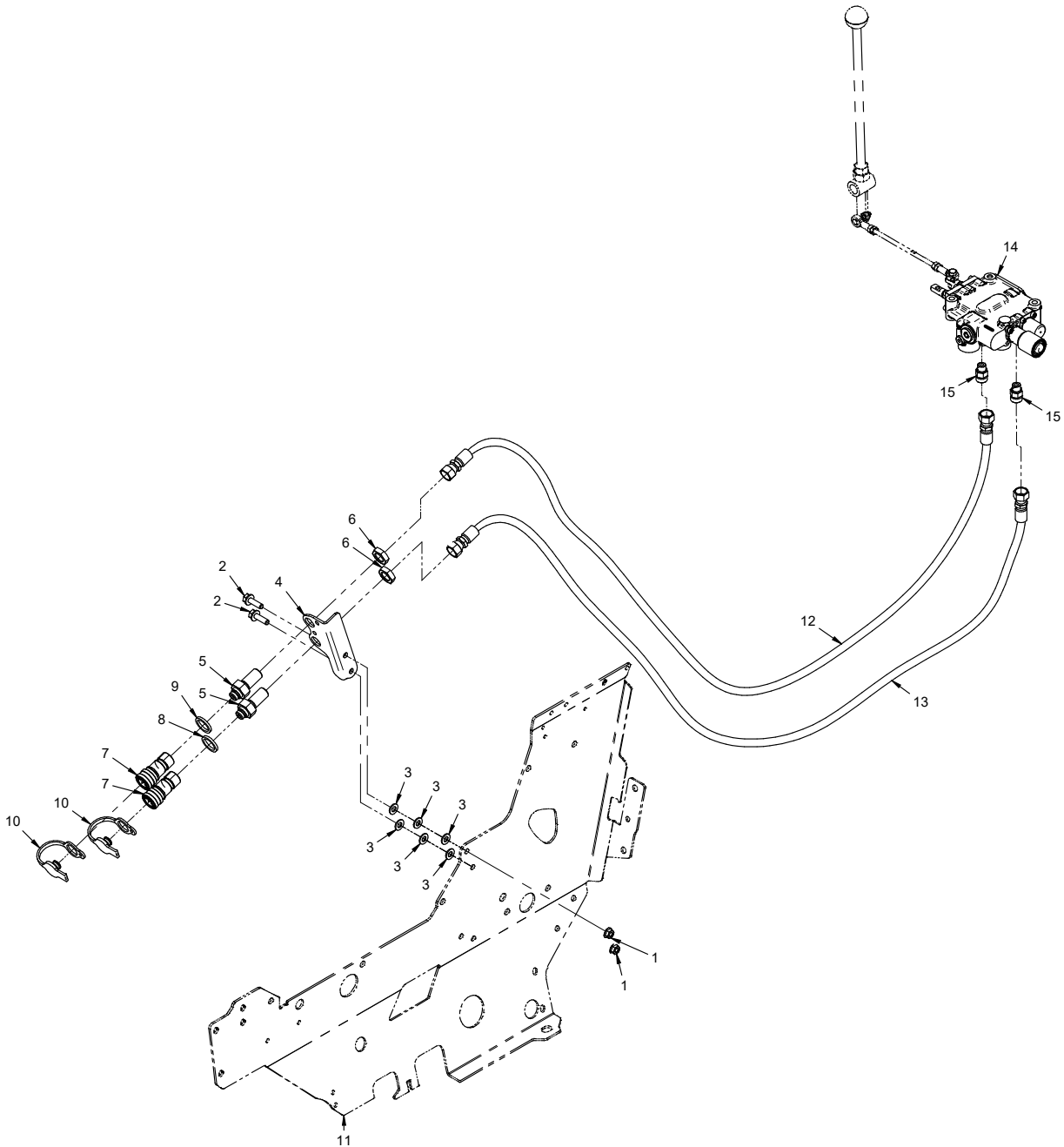

HYDRAULICS, AXLES, & WHEELS

Auxiliary Hydraulic Quick Couplers

REF.	PART NO.	DESCRIPTION	QTY.
1	99.SF05	Nut, SRF 5/16-18 USS	2
2	99.SF0508-1	Bolt, SMF 5/16-18 x 1	2
3	95.05	Washer, Flat 5/16 SAE	6
4	KN-1064	Bracket, Hyd Coupler 2 Pos	1
5	25.FF2764-06-06-LN	Fitting, Bulkhead Straight 3/8 W/Locknut	2
6	25.FF306-06	Locknut, -06 Bulkhead Fitting	2
7	23.0197	Coupler, Hyd Quick Female 1/4 ORB	2
8	05.0190	Washer, .905 ID x 1.170 x .140 Red	1
9	05.0191	Washer, .905 ID x 1.170 x .140 Yellow	1
10	23.0126	Plug, Dust	2
11	KN-1078	Panel, Main Right	1
12	20.0398	Hose, 1/4x58.00 SAE 100R17AR	1
13	20.0398	Hose, 1/4x58.00 SAE 100R17AR	1
14	23.0201	Valve, 2 Spool W/LH Flt, RH SP (See Hydraulics, Axles, & Wheels Section for details)	1
15	25.FF6400-06-06	Fitting, Connector -06MF x -06MB	2

HYDRAULICS, AXLES, & WHEELS

ILLUSTRATED DRAWING

Front Hydraulic Motor Mount & Fittings

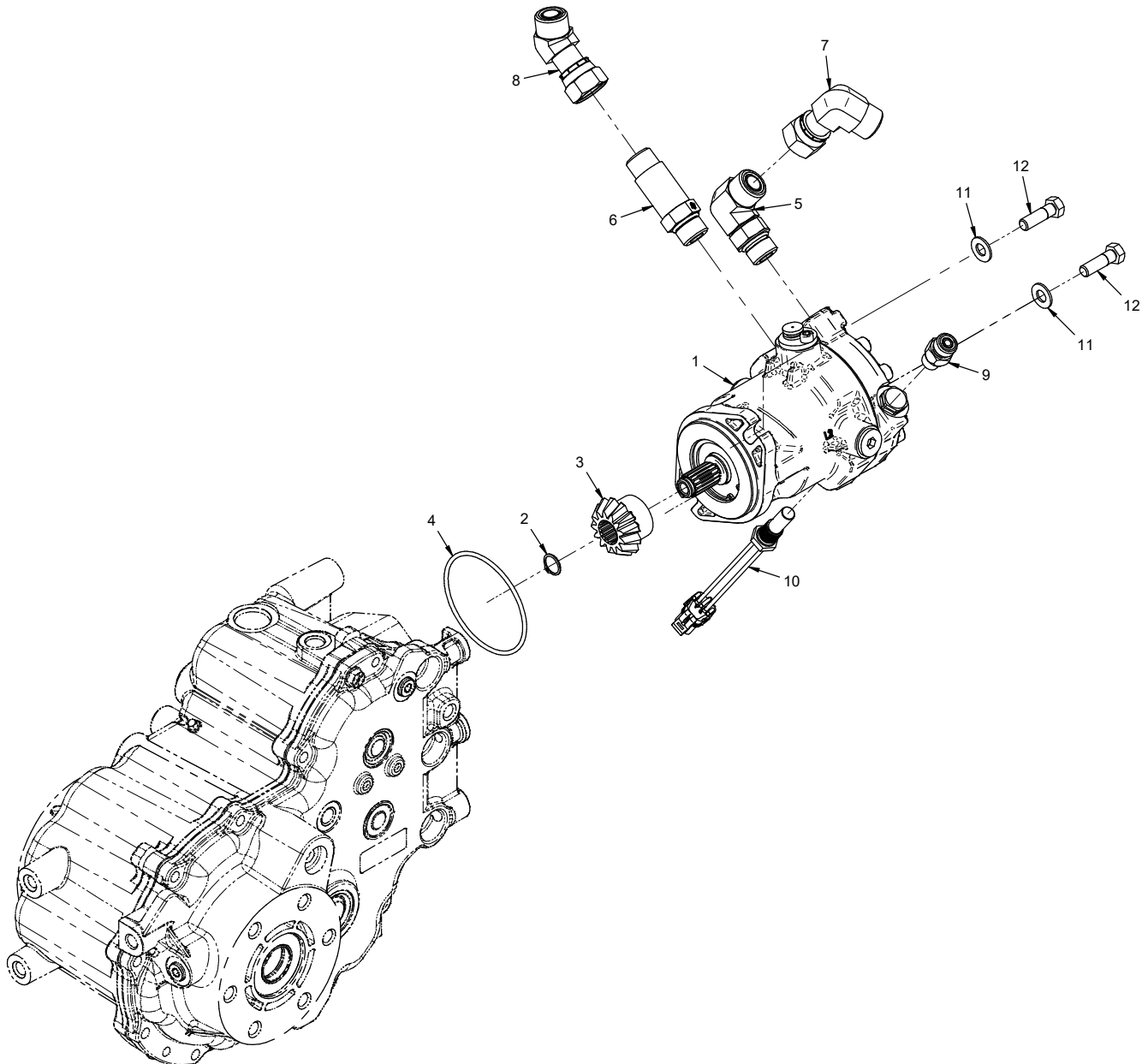

HYDRAULICS, AXLES, & WHEELS

Front Hydraulic Motor Mount & Fittings

REF.	PART NO.	DESCRIPTION	QTY.
1	21.0149	Motor, Hyd. Danfoss 20cc/Rev	1
2	04.0015	Snap Ring, Ext .039 x .588	1
3	87.0259	Gear, Pinion Motor to Axle	1
4	26.0024	O-ring 3-1/4 x 3-1/2 x 1/8	1
5	25.FF6801-10-10	Fitting, 90 Elbow -10MF x -10MB	1
6	25.FF6400-L-10-10	Fitting, Connector Long -10MF x -10MB	1
7	25.FF6500-10-10	Fitting, 90 Elbow -10MF x -10FF	1
8	25.FF6502-10-10	Fitting, 45 Elbow -10MF x -10FF	1
9	23.0200	Valve, Check Parker 5 PSI, 06 ORB	1
10	13.0341	Switch, Temp -06 SAE ORB	1
11	95.06	Washer, Flat 3/8 SAE (Serial # 08442-)	2
12	99.SF0610-1	Bolt, SMF 3/8-16 USS x 1-1/4 (Serial # 01001-08441)	2
12	90.0610	Bolt, 3/8-16 USS x 1-1/4 (Serial # 08442-)	2

HYDRAULICS, AXLES, & WHEELS

ILLUSTRATED DRAWING

Rear Hydraulic Motor Mount & Fittings

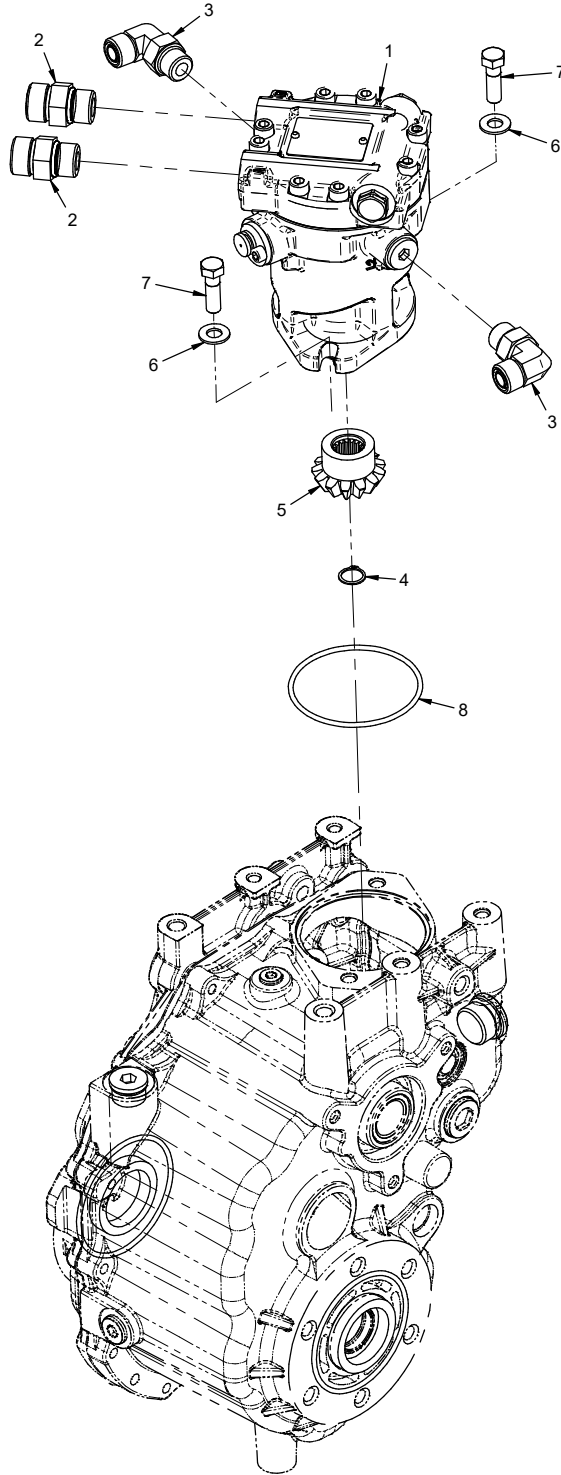

HYDRAULICS, AXLES, & WHEELS

Rear Hydraulic Motor Mount & Fittings

REF.	PART NO.	DESCRIPTION	QTY.
1	21.0149	Motor, Hyd. Danfoss 20cc/Rev	1
2	25.FF6400-10-10	Fitting, Connector 10MFF x 10MB	2
3	25.FF6801-08-08	Fitting, 90 Elbow 8MFF x 8MB	2
4	04.0015	Snap Ring, Ext .039 x .588	1
5	87.0259	Gear, Pinion Motor to Axle	1
6	95.06	Washer, Flat 3/8 SAE (Serial # 08442-)	2
7	99.SF0610-1	Bolt, SMF 3/8-16 USS x 1-1/4 (Serial # 01001-08441)	2
7	90.0610	Bolt, 3/8-16 USS x 1-1/4 (Serial # 08442-)	2
8	26.0024	O-ring 3-1/4 x 3-1/2 x 1/8	1

HYDRAULICS, AXLES, & WHEELS

Hydraulic Pump Mount & Fittings

REF.	PART NO.	DESCRIPTION	QTY.
1	99.SF08	Nut, SRF 1/2-13 USS	2
2	25.FF6400-L-10-10	Fitting, Connector Long -10MF x -10MB	2
3	25.FF6801-06-06	Fitting, 90 Elbow - 6MFF X 6MB	1
4	21.0148	Pump, Hyd. Danfoss 20cc	1
5	25.FF6801-12-10	Fitting, 90 Elbow -12MF x -10MB	1
6	97.0812	Bolt, Carriage 1/2-13 x 1 1/2	2
7	KN-1089	Plate, Pump Bolt Mount	2
8	25.FF6803-8-8-8	Fitting, Tee -08MF x -08MF x -08MB	1
9	25.FF6802-08-08	Fitting, 45 Elbow - 8Mff X 8Mb.	1
10	25.FF6400-06-06	Fitting, Connector -06MF x -06MB	1
11	85.K0406	Key, 1/4 X 3/4	1

HYDRAULICS, AXLES, & WHEELS

ILLUSTRATED DRAWING Hydraulic Oil Cooler & Fan

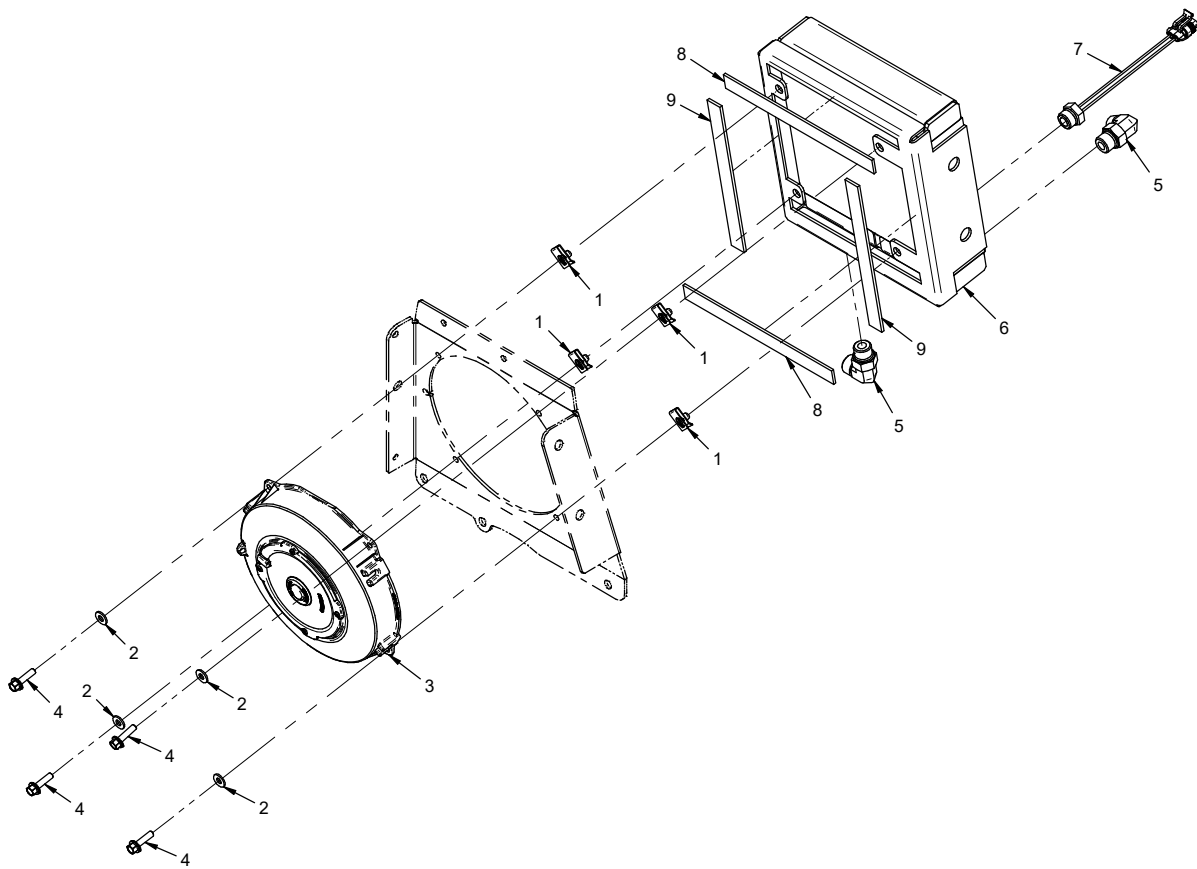

HYDRAULICS, AXLES, & WHEELS

Hydraulic Oil Cooler & Fan

REF.	PART NO.	DESCRIPTION	QTY.
1	99.E0046	Nut, "U" 1/4-20 Extruded	4
2	95.04	Washer, Flat 1/4 SAE	4
3	37.0057	Fan, Electric 7.5"	1
4	99.SF0408	Bolt, SRF 1/4 x 1 USS	4
5	25.FF6801-08-08	Fitting, 90 Elbow 8MFF x 8MB	2
6	21.0155	Cooler, Hydraulic	1
7	13.0239	Switch, Temperature 170F	1
8	06.0045-8.75IN	Weatherstrip, 1/8 X 3/4 X 8-3/4"	2
9	06.0045-8.25IN	Weatherstrip, 1/8 X 3/4 X 8-1/4"	2

HYDRAULICS, AXLES, & WHEELS

ILLUSTRATED DRAWING Hydraulic Drive Circuit Hoses

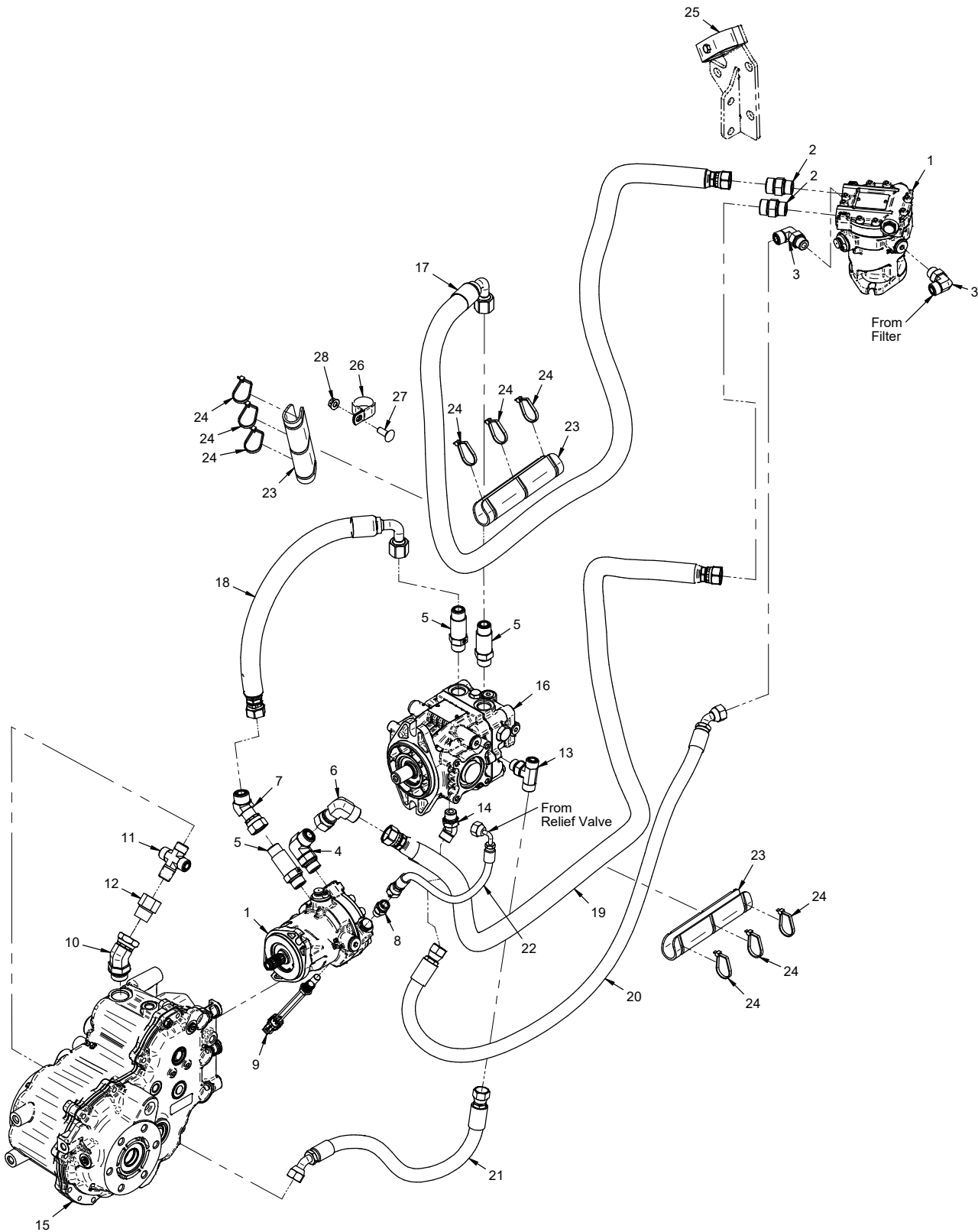

HYDRAULICS, AXLES, & WHEELS

Hydraulic Drive Circuit Hoses

REF.	PART NO.	DESCRIPTION	QTY.
1	21.0149	Motor, Hyd. Danfoss 20cc/Rev	2
2	25.FF6400-10-10	Fitting, Connector 10MFF x 10MB	2
3	25.FF6801-08-08	Fitting, 90 Elbow 8MFF x 8MB	2
4	25.FF6801-10-10	Fitting, 90 Elbow -10MF x -10MB	1
5	25.FF6400-L-10-10	Fitting, Connector Long -10MF x -10MB	3
6	25.FF6500-10-10	Fitting, 90 Elbow -10MF x -10FF	1
7	25.FF6502-10-10	Fitting, 45 Elbow -10MF x -10FF	1
8	23.0200	Valve, Check Parker 5 PSI, 06 ORB	1
9	13.0341	Switch, Temp -06 SAE ORB	1
10	25.6902-12-12	Fitting, 45 MFE 3/4 x 3/4	1
11	25.FF2651MP-08-08-08-08	Fitting, Cross 08FF	1
12	25.5405-12-08	Fitting, Reducer 3/4 X 1/2	1
13	25.FF6803-8-8-8	Fitting, Tee -08MF x -08MF x -08MB	1
14	25.FF6802-08-08	Fitting, 45 Elbow - 8Mff X 8Mb	1
15	51.0087	Transaxle, Peerless	1
16	21.0148	Pump, Hyd. Danfoss 20cc	1
17	20.0405	Hose, 3/4x75.50 SS Braid PTFE	1
18	20.0406	Hose, 3/4x20.00 SS Braid PTFE	1
19	20.0414	Hose, 5/8 x 53.00 SAE 100R16	1
20	22.0079	Hose, 1/2x49.00 ASTM D380 / ASTM D6751	1
21	22.0081	Hose, 1/2x29.00 ASTM D380 / ASTM D6751	1
22	22.0089	Hose, 1/4x12.50 ASTM D380 / ASTM D6751	1
23	44.0258	Sleeve, Hose Protector 8"	3
24	30.0204	Tyton Tie, #50 .190 x 12"	9
25	44.0416	Clamp, Hyd Hose 32mm ID 2 Cavity	1
26	44.0418	Clamp, 1-1/4" Loop Vinyl Cushion	1
27	97.0608	Bolt, Carriage 3/8-16 x 1	1
28	99.E0082	Nut, Locking Flange 3/8-16	1

HYDRAULICS, AXLES, & WHEELS

ILLUSTRATED DRAWING

Pump Supply Line & Main Hydraulic Filter

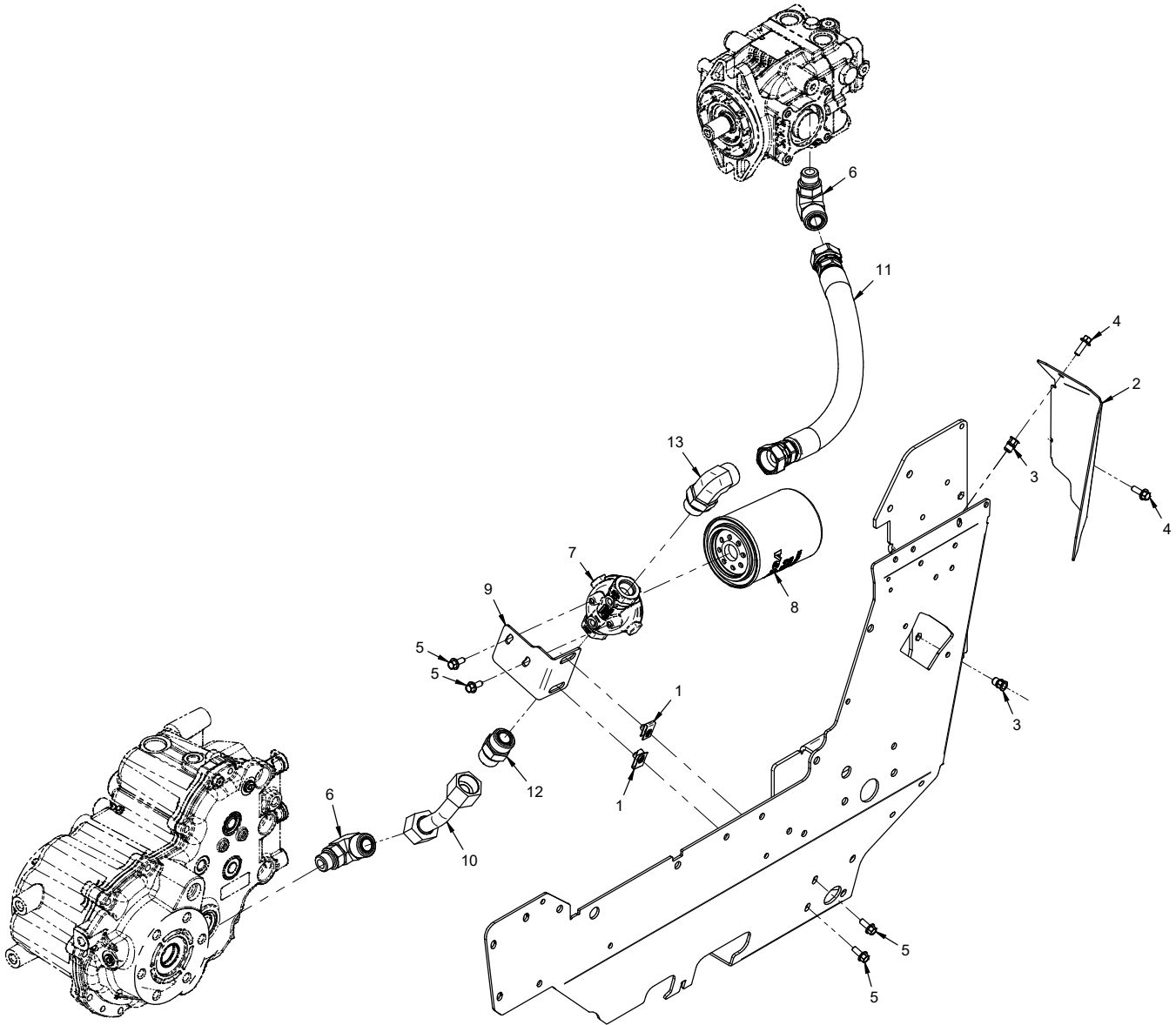

HYDRAULICS, AXLES, & WHEELS

Pump Supply Line & Main Hydraulic Filter

REF.	PART NO.	DESCRIPTION	QTY.
1	99.E0046	Nut, "U" 1/4-20 Extruded	2
2	KN-1052	Cover, Hyd Filter Access	1
3	99.E0105	Nut, Insert 1/4-20 Hex	2
4	99.SF0406-1	Bolt, SMF 1/4-20 X 3/4	2
5	99.SF0405-1	Bolt, SMF 1/4-20 X 5/8	4
6	25.FF6801-12-10	Fitting, 90 Elbow -12MF x -10MB	2
7	21.0153	Filter, Head -12 ORB Ports	1
8	21.0122	Filter, Hyd. 25 Micron Syn.	1
9	KN-1105	Bracket, Oil Filter Mounting	1
10	20.0403	Steel Tube, 3/4" OD x .065 Wall	1
11	22.0088	Hose, 3/4x16.00 SAE 100R4ExFlex	1
12	25.FF6400-12-12	Fitting, Connector -12MF x -12MB	1
13	25.FF6801-12-12	Fitting, 90 Elbow -12MF x -12MB	1

HYDRAULICS, AXLES, & WHEELS

ILLUSTRATED DRAWING

Hydraulic Implement Circuit Supply & Return (Serial # 01001-02391)

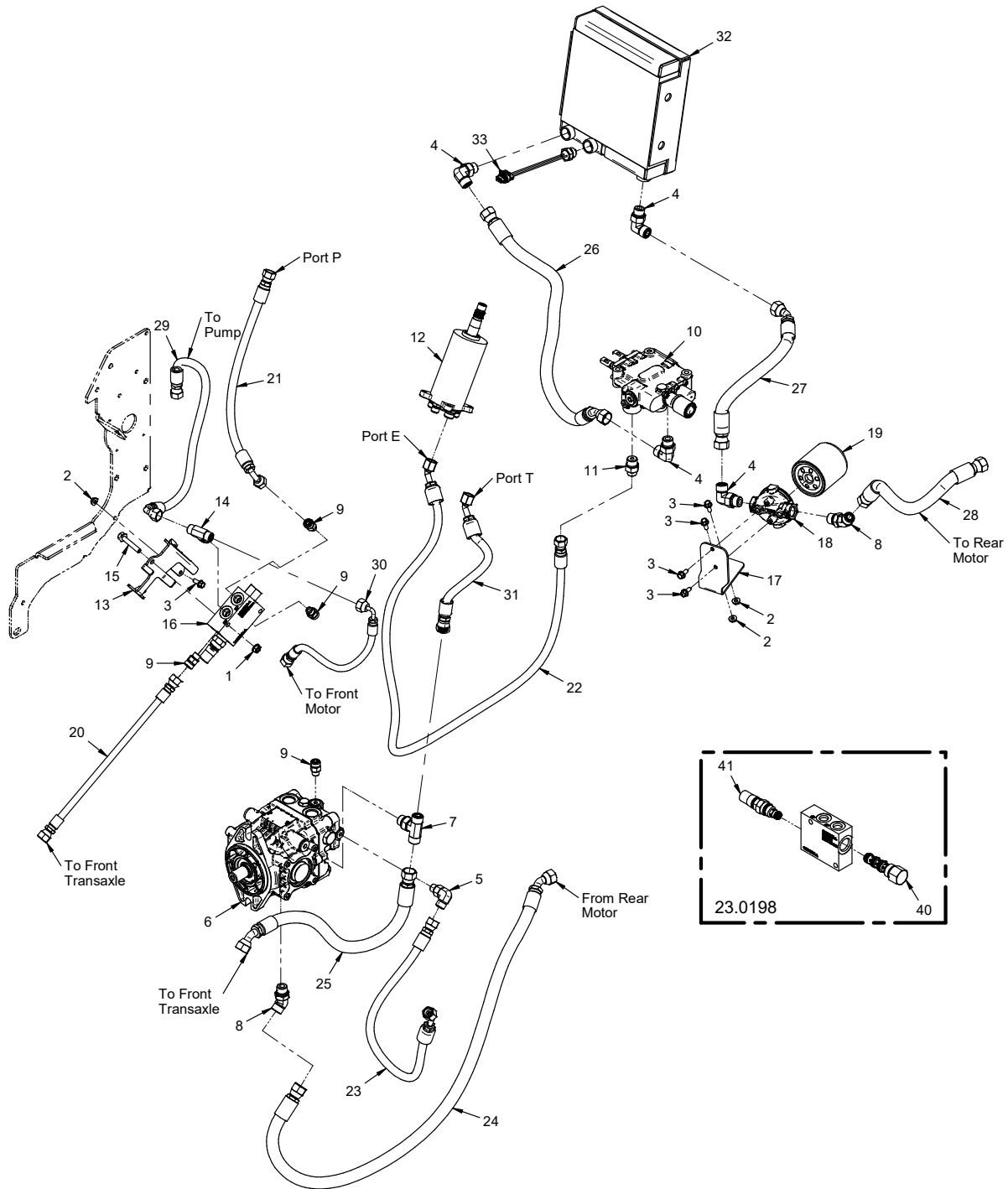

HYDRAULICS, AXLES, & WHEELS

Hydraulic Implement Circuit Supply & Return (Serial # 01001-02391)

REF.	PART NO.	DESCRIPTION	QTY.
1	99.SF05	Nut, SRF 5/16-18 USS	1
2	99.SF04	Nut, SRF 1/4-20 USS	3
3	99.SF0405-1	Bolt, SMF 1/4-20 X 5/8	5
4	25.FF6801-08-08	Fitting, 90 Elbow 8MFF x 8MB	4
5	25.FF6801-06-06	Fitting, 90 Elbow - 6MFF X 6MB	1
6	21.0148	Pump, Hyd. Danfoss 20cc	1
7	25.FF6803-8-8-8	Fitting, Tee -08MF x -08MF x -08MB	1
8	25.FF6802-08-08	Fitting, 45 Elbow - 8Mff X 8MB	2
9	25.FF6400-06-06	Fitting, Connector -06MFF x -06MB	4
10	23.0201	Valve, 2 Spool W/LH Flt, RH	1
11	25.FF6400-06-08	Fitting, Connector 06MFF x 08MB	1
12	23.0199	Valve, Steering	1
13	KN-1033	Mount, Priority Valve	1
14	25.FF6803-6-6-6	Fitting, Tee -06MF x -06MF x -06MB	1
15	99.SF0514-1	Bolt, SMF 5/16-18 x 1-3/4	1
16	23.0198	Valve Block, Priority/Relief	1
17	KN-1000	Bracket, Filter Mount	1
18	21.0154	Filter, Head 08 ORB	1
19	21.0124	Filter, Hyd. 10 Micron Cel.	1
20	22.0091	Hose, 1/4x14.50 ASTM D380/ASTM D6751	1
21	20.0394	Hose, 3/8x18.50 SAE 100R17AR	1
22	20.0395	Hose, 3/8x59.00 SAE 100R17AR	1
23	20.0396	Hose, 3/8x19.00 SAE 100R17AR	1
24	22.0079	Hose, 1/2x49.00 ASTM D380 / ASTM D6751	1
25	22.0081	Hose, 1/2x29.00 ASTM D380 / ASTM D6751	1
26	22.0082	Hose, 1/2x32.00 ASTM D380 / ASTM D6751	1
27	22.0084	Hose, 1/2x14.50 ASTM D380 / ASTM D6751	1
28	22.0085	Hose, 1/2x15.00 ASTM D380 / ASTM D6751	1
29	22.0086	Hose, 3/8x21.00 ASTM D380 / ASTM D6751	1
30	22.0089	Hose, 1/4x12.50 ASTM D380 / ASTM D6751	1
31	22.0090	Hose, 3/8x9.50 ASTM D380 / ASTM D6751	1
32	21.0155	Cooler, Hydraulic	1
33	13.0239	Switch, Temperature 170F	1
40	23.0213	Valve, Priority Cartridge	1
41	23.0214	Valve, Cartridge, Relief Valve	1

HYDRAULICS, AXLES, & WHEELS

ILLUSTRATED DRAWING

Hydraulic Implement Circuit Supply & Return (Serial # 02392-)

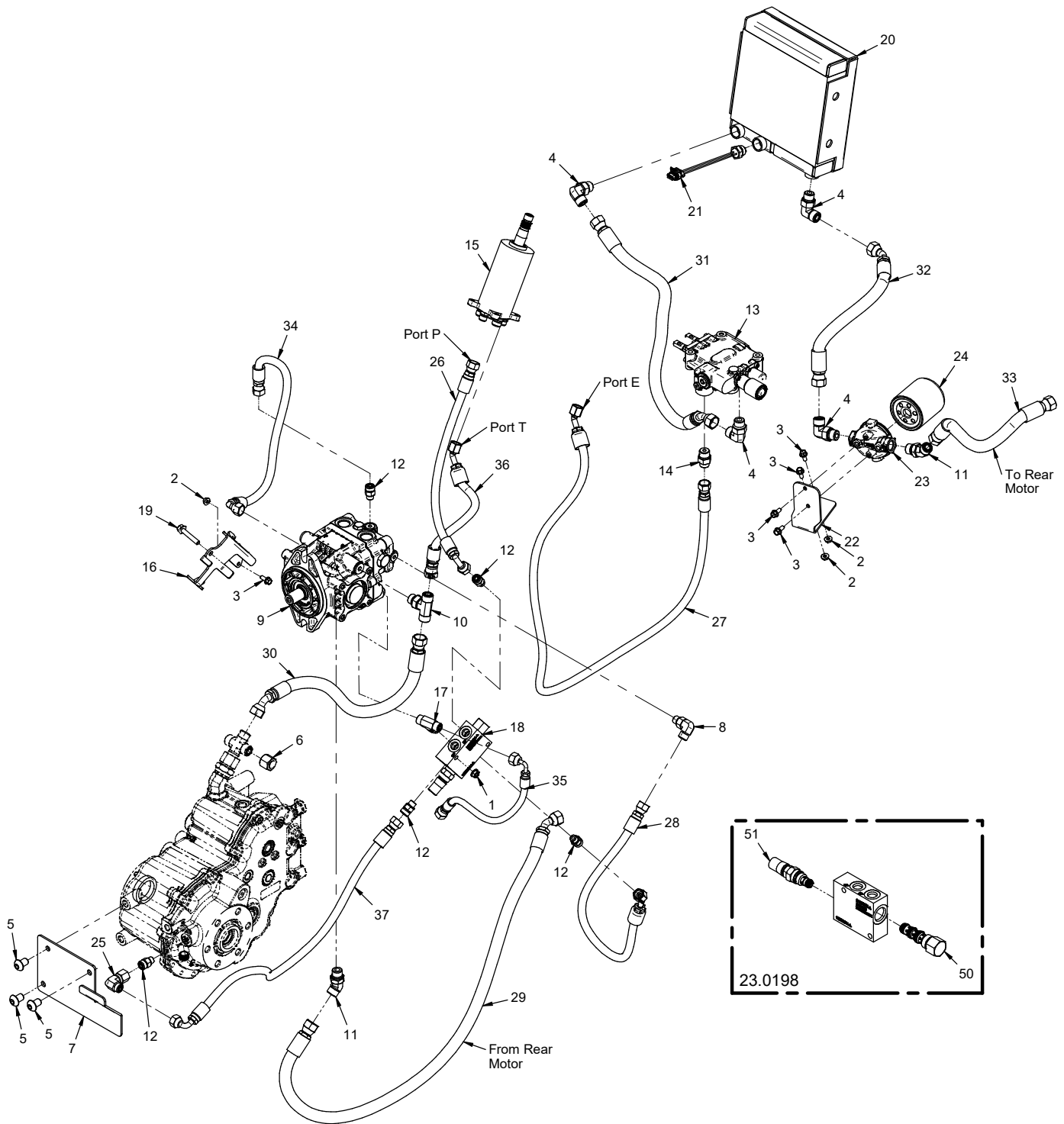

HYDRAULICS, AXLES, & WHEELS

Hydraulic Implement Circuit Supply & Return (Serial # 02392-)

REF.	PART NO.	DESCRIPTION	QTY.
1	99.SF05	Nut, SRF 5/16-18 USS	1
2	99.SF04	Nut, SRF 1/4-20 USS	3
3	99.SF0405-1	Bolt, SMF 1/4-20 X 5/8	5
4	25.FF6801-08-08	Fitting, 90 Elbow 8MFF x 8MB	4
5	99.0806	Bolt, 1/2-13 X 3/4 (Serial # 03325-)	3
6	25.FF304-C-08	Fitting, Cap -08 ORFS	1
7	KN-533	Shield, Pressure Relief Hose (Serial # 03325-)	1
8	25.FF6801-06-06	Fitting, 90 Elbow - 6MFF X 6MB	1
9	21.0148	Pump, Hyd. Danfoss 20cc	1
10	25.FF6803-8-8-8	Fitting, Tee -08MF x -08MF x -08MB	1
11	25.FF6802-08-08	Fitting, 45 Elbow - 8Mff X 8Mb	2
12	25.FF6400-06-06	Fitting, Connector -06MFF x -06MB	5
13	23.0201	Valve, 2 Spool W/LH Flt, RH	1
14	25.FF6400-06-08	Fitting, Connector 06MFF x 08MB	1
15	23.0199	Valve, Steering	1
16	KN-1033	Mount, Priority Valve	1
17	25.FF6803-6-6-6	Fitting, Tee -06MF x -06MF x -06MB	1
18	23.0198	Valve Block, Priority/Relief	1
19	99.SF0514-1	Bolt, SMF 5/16-18 x 1-3/4	1
20	21.0155	Cooler, Hydraulic	1
21	13.0239	Switch, Temperature 170F	1
22	KN-1000	Bracket, Filter Mount	1
23	21.0154	Filter, Head 08 ORB	1
24	21.0124	Filter, Hyd. 10 Micron Cel.	1
25	25.FF6500-06-06	Fitting, 90 Elbow 6Mff X 6Ffs	1
26	20.0394	Hose, 3/8x18.50 SAE 100R17AR	1
27	20.0395	Hose, 3/8x59.00 SAE 100R17AR	1
28	20.0396	Hose, 3/8x19.00 SAE 100R17AR	1
29	22.0079	Hose, 1/2x49.00 ASTM D380 / ASTM D6751	1
30	22.0081	Hose, 1/2x29.00 ASTM D380 / ASTM D6751	1
31	22.0082	Hose, 1/2x32.00 ASTM D380 / ASTM D6751	1
32	22.0084	Hose, 1/2x14.50 ASTM D380 / ASTM D6751	1
33	22.0085	Hose, 1/2x15.00 ASTM D380 / ASTM D6751	1
34	22.0086	Hose, 3/8x21.00 ASTM D380 / ASTM D6751	1
35	22.0089	Hose, 1/4x12.50 ASTM D380 / ASTM D6751	1
36	22.0090	Hose, 3/8x9.50 ASTM D380 / ASTM D6751	1
37	20.0419	Hose, 3/8x26.00 SAE 100R17AR	1
50	23.0213	Valve, Priority Cartridge	1
51	23.0214	Valve, Cartridge, Relief Valve	1

HYDRAULICS, AXLES, & WHEELS

ILLUSTRATED DRAWING Front Transaxle & Wheels

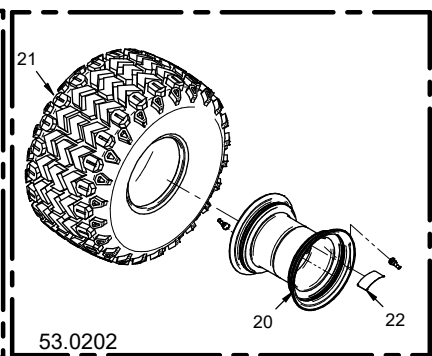
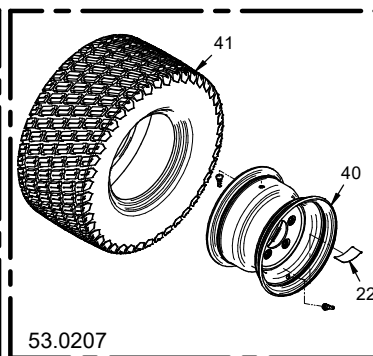
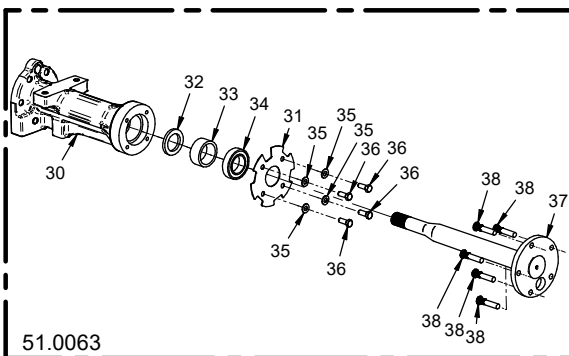
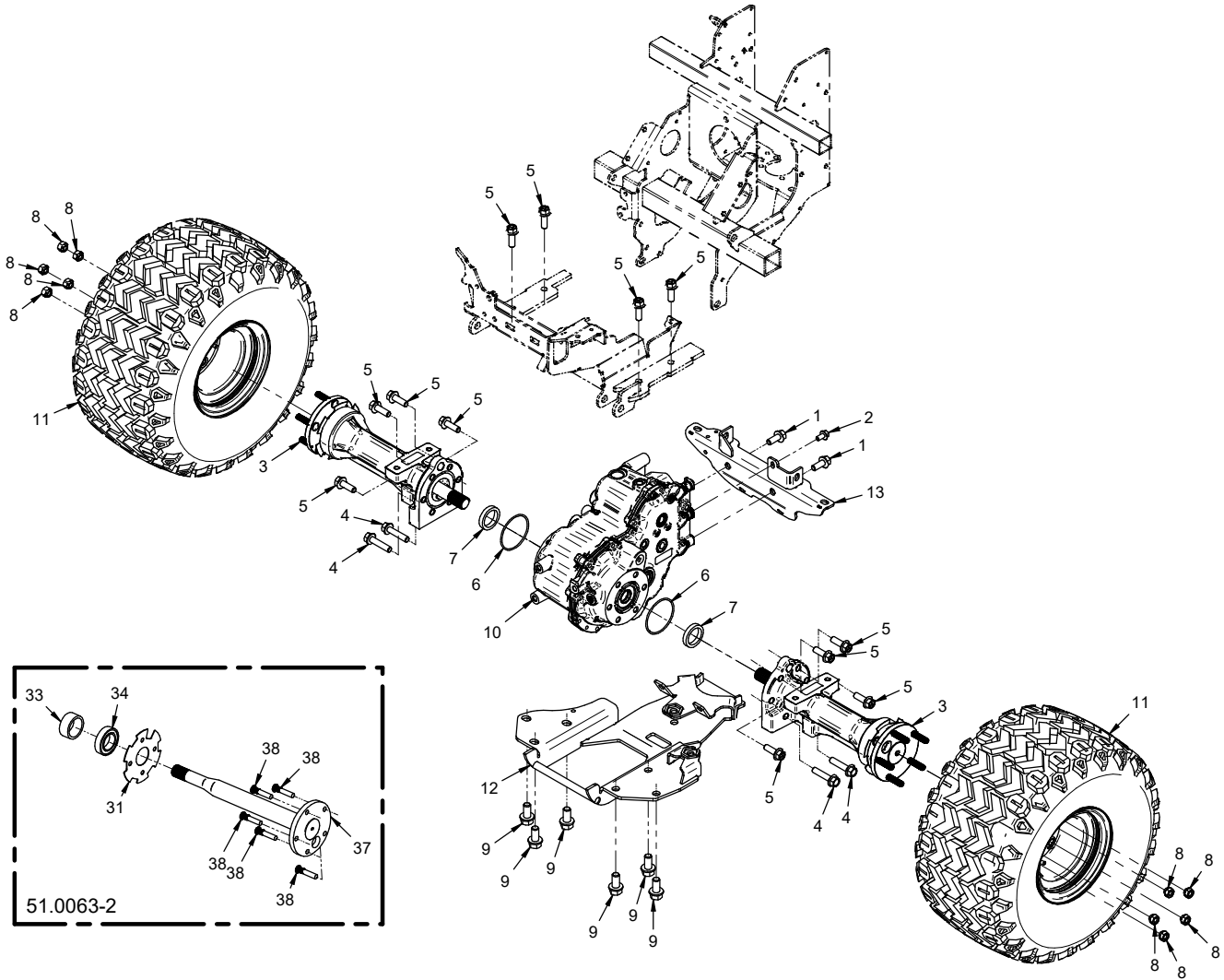

HYDRAULICS, AXLES, & WHEELS

Front Transaxle & Wheels

REF.	PART NO.	DESCRIPTION	QTY.
1	99.SF0810-1	Bolt, SMF 1/2-13 x 1-1/4	2
2	99.SF0606-1	Bolt, SMF 3/8-16 USS x 3/4	1
3	51.0063	Axle, Asm 40MM Forged Shaft	2
4	99.SF0818-1	Bolt, SMF 1/2-13 x 2-1/4	4
5	99.SF0812-1	Bolt, SMF 1/2-13 x 1-1/2	12
6	26.0024	O-ring 3-1/4 x 3-1/2 x 1/8	2
7	51.0022	Spacer, Axle For Housing Assy	2
8	99.E0044	Nut, Lug 7/16-20 SAE	10
9	99.SF1010-1	Bolt, SMF 5/8-11 x 1-1/4	6
10	29.P06H	Pipe, Plug 3/8 Hex ZP	1
11	51.0087	Transaxle, Peerless	1
12	53.0202	Wheel, Asm 22x12x8 Field Trax	2
13	62.1371	Frame, Connector Link Mount	1
14	KN-6013	Bracket, Connector Frame MT	1
20	53.0203	Rim, 8 X 8.5, 5 On 4.5 BC	1
21	53.0089	Tire, Field 22 X 12 X 8-No Rim	1
22	00.0645	Decal, Hub Side	1
30	51.0063-1	Housing, Axle Peerless KT	1
31	51.0063-4	Plate, Cover Peerless Axle	1
32	89.0074	Seal, Oil Peerless Axle 51.0063	1
33	51.0063-3	Spacer, Axle Peerless KT	1
34	55.0063	Bearing, Axle Peerless 51.0063	1
35	95.06	Washer, Flat 3/8 SAE	4
36	90.0608	Bolt, 3/8-16 USS x 1	4
37	51.0063-5	Shaft, Axle W/Hub Peerless	1
38	99.K0100	Bolt, Whl/Std 7/16-20 x 2-1/8	5
40	53.0208	Rim, 10 X 7 - 5 On 4.5 BC	1
41	53.0112	Tire, Turfmastr 22X11X10 No Rim	1

HYDRAULICS, AXLES, & WHEELS

ILLUSTRATED DRAWING Rear Transaxle & Wheels (Serial # 01001-05664)

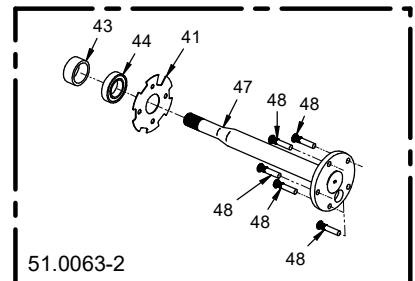
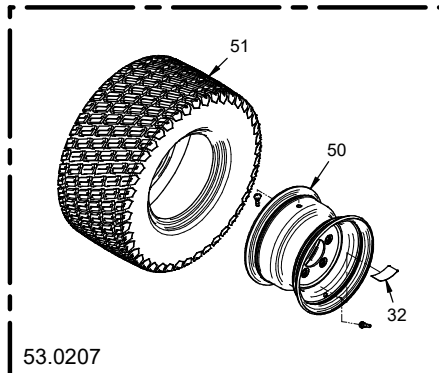
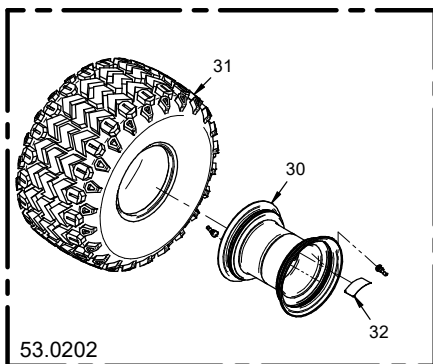
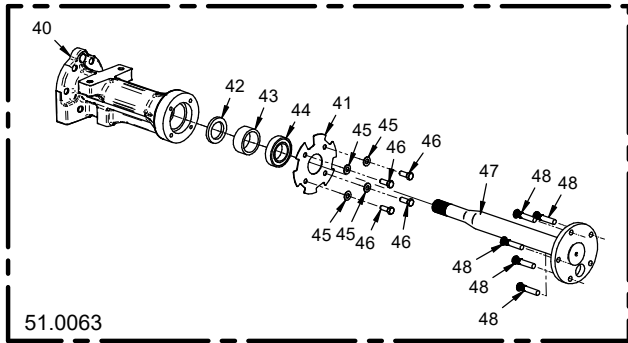
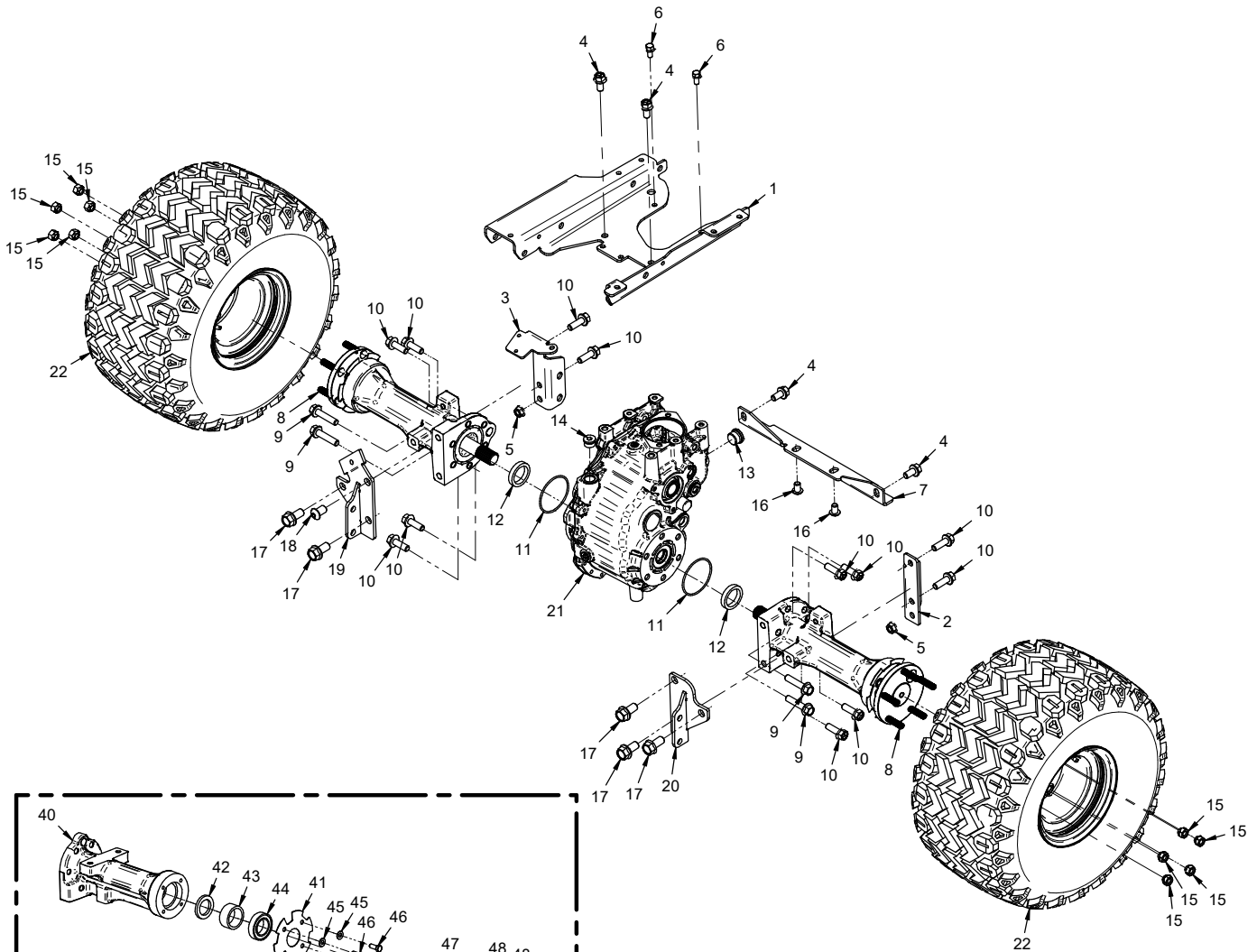

HYDRAULICS, AXLES, & WHEELS

Rear Transaxle & Wheels (Serial # 01001-05664)

REF.	PART NO.	DESCRIPTION	QTY.
1	KN-1027	.Frame, Rear Upper	1
2	64.1865	.Bracket, Rear Hitch Mt Left	1
3	KN-1032	.Bracket, Rear Hitch Mt Right	1
4	99.SF0808-1	.Bolt, SMF 1/2-13 x 1	4
5	99.SF08	.Nut, SRF 1/2-13 USS	2
6	99.SF0606-1	.Bolt, SMF 3/8-16 USS x 3/4	2
7	64.1864	.Bracket, Rear Transaxle	1
8	51.0063	.Axle, Asm 40MM Forged Shaft	2
9	99.SF0818-1	.Bolt, SMF 1/2-13 x 2-1/4	4
10	99.SF0812-1	.Bolt, SMF 1/2-13 x 1-1/2	12
11	26.0024	.O-ring 3-1/4 x 3-1/2 x 1/8	2
12	51.0022	.Spacer, Axle For Housing Assy	2
13	25.6408-H-12	.Fitting, -12 MB x Hollow Allen	1
14	25.6408-H-10	.Fitting, Plug 10MB x Hollow Allen	1
15	99.E0044	.Nut, Lug 7/16-20 SAE	10
16	99.0806	.Bolt, 1/2-13 X 3/4	2
17	99.SF1010-1	.Bolt, SMF 5/8-11 x 1-1/4	5
18	99.1008	.Bolt, 5/8-11 x 1 BSCS	1
19	KN-6025	.Bracket, Transaxle Mount Right	1
20	64.1594	.Bracket, Transaxle Mount Left	1
21	51.0087	.Transaxle, Peerless	1
22	53.0202	.Wheel, Asm 22x12x8 Field Trax	2
30	53.0203	.Rim, 8 X 8.5, 5 On 4.5 BC	1
31	53.0089	.Tire, Field 22 X 12 X 8-No Rim	1
32	00.0645	.Decal, Hub Side	1
40	51.0063-1	.Housing, Axle Peerless KT	1
41	51.0063-4	.Plate, Cover Peerless Axle	1
42	89.0074	.Seal, Oil Peerless Axle 51.0063	1
43	51.0063-3	.Spacer, Axle Peerless KT	1
44	55.0063	.Bearing, Axle Peerless 51.0063	1
45	95.06	.Washer, Flat 3/8 SAE	4
46	90.0608	.Bolt, 3/8-16 USS x 1	4
47	51.0063-5	.Shaft, Axle W/Hub Peerless	1
48	99.K0100	.Bolt, Whl/Std 7/16-20 x 2-1/8	5
50	53.0208	.Rim, 10 X 7 - 5 On 4.5 BC	1
51	53.0112	.Tire, Turfmastr 22X11X10 No Rim	1

HYDRAULICS, AXLES, & WHEELS

ILLUSTRATED DRAWING Rear Transaxle & Wheels (Serial # 05665-)

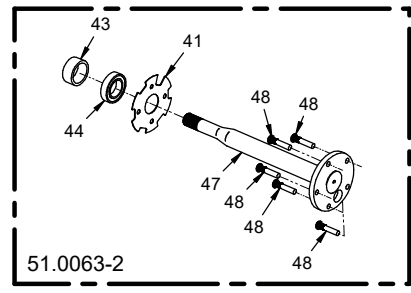
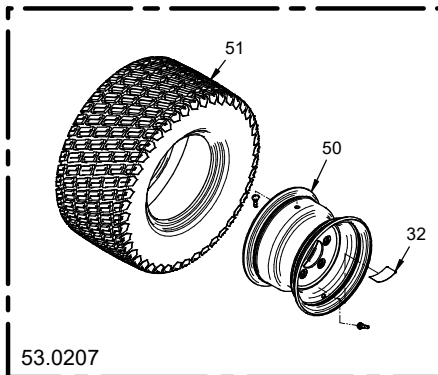
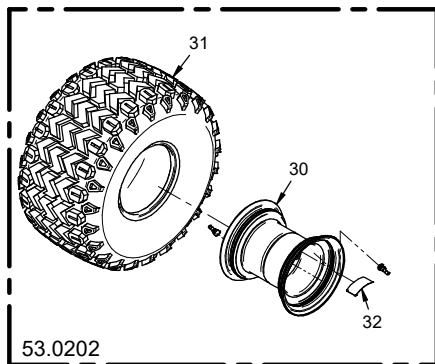
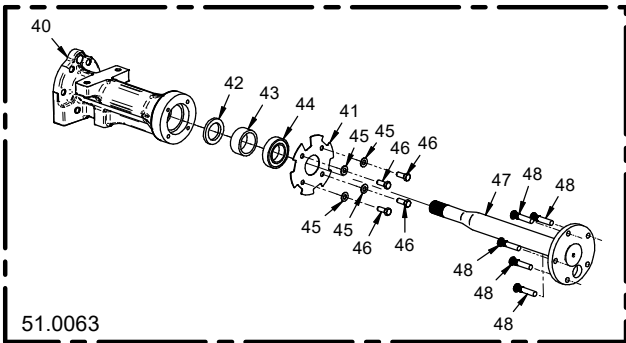
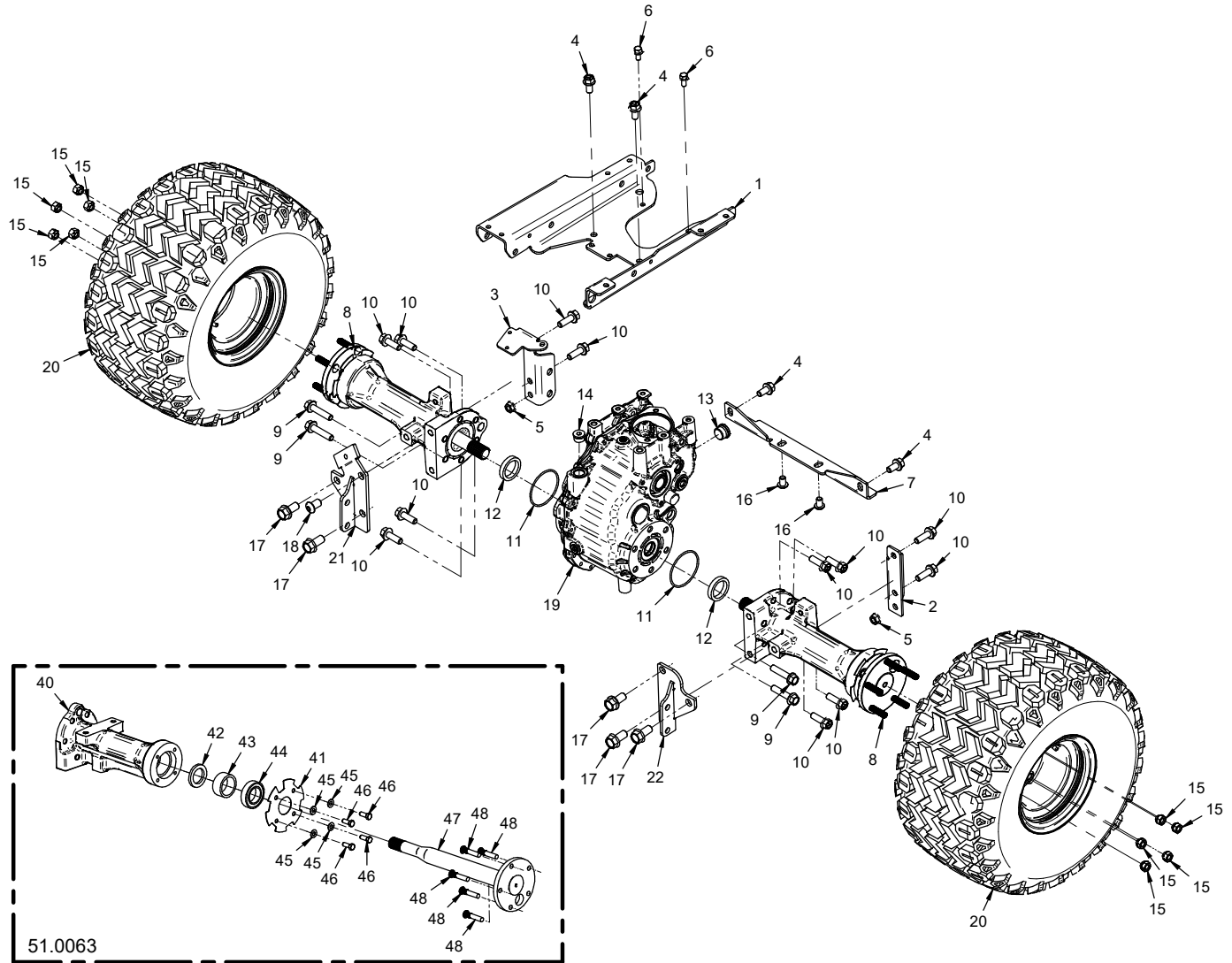

HYDRAULICS, AXLES, & WHEELS

Rear Transaxle & Wheels (Serial # 05665-)

REF.	PART NO.	DESCRIPTION	QTY.
1	KN-1484	.Frame, Rear Upper	1
2	64.1865	.Released For Production	1
3	KN-1032	.Bracket, Rear Hitch Mt Right	1
4	99.SF0808-1	.Bolt, SMF 1/2-13 x 1	4
5	99.SF08	.Nut, SRF 1/2-13 USS	2
6	99.SF0606-1	.Bolt, SMF 3/8-16 USS x 3/4	2
7	64.1864	.Added Identification Notch For Brake	1
8	51.0063	.Axle, Asm 40MM Forged Shaft	2
9	99.SF0818-1	.Bolt, SMF 1/2-13 x 2-1/4	4
10	99.SF0812-1	.Bolt, SMF 1/2-13 x 1-1/2	12
11	26.0024	.O-ring 3-1/4 x 3-1/2 x 1/8	2
12	51.0022	.Spacer, Axle For Housing Assy	2
13	25.6408-H-12	.Fitting, -12 MB x Hollow Allen	1
14	25.6408-H-10	.Fitting, Plug 10MB x Hollow Allen	1
15	99.E0044	.Nut, Lug 7/16-20 SAE	10
16	99.0806	.Bolt, 1/2-13 X 3/4	2
17	99.SF1010-1	.Bolt, SMF 5/8-11 x 1-1/4	5
18	99.1008	.Bolt, 5/8-11 x 1 BSCS	1
19	51.0087	.Transaxle, Peerless	1
20	53.0202	.Wheel, Asm 22x12x8 Field Trax	2
21	KN-6025	.Bracket, Transaxle Mount Right	1
22	64.1594	.Bracket, Transaxle Mount Left	1
30	53.0203	.Rim, 8 X 8.5, 5 On 4.5 BC	1
31	53.0089	.Tire, Field 22 X 12 X 8-No Rim	1
32	00.0645	.Decal, Hub Side	1
40	51.0063-1	.Housing, Axle Peerless KT	1
41	51.0063-4	.Plate, Cover Peerless Axle	1
42	89.0074	.Seal, Oil Peerless Axle 51.0063	1
43	51.0063-3	.Spacer, Axle Peerless KT	1
44	55.0063	.Bearing, Axle Peerless 51.0063	1
45	95.06	.Washer, Flat 3/8 SAE	4
46	90.0608	.Bolt, 3/8-16 USS x 1	4
47	51.0063-5	.Shaft, Axle W/Hub Peerless	1
48	99.K0100	.Bolt, Whl/Std 7/16-20 x 2-1/8	5
50	53.0208	.Rim, 10 X 7 - 5 On 4.5 BC	1
51	53.0112	.Tire, Turfmastr 22X11X10 No Rim	1

HYDRAULICS, AXLES, & WHEELS

ILLUSTRATED DRAWING Peerless Transaxle (51.0087)

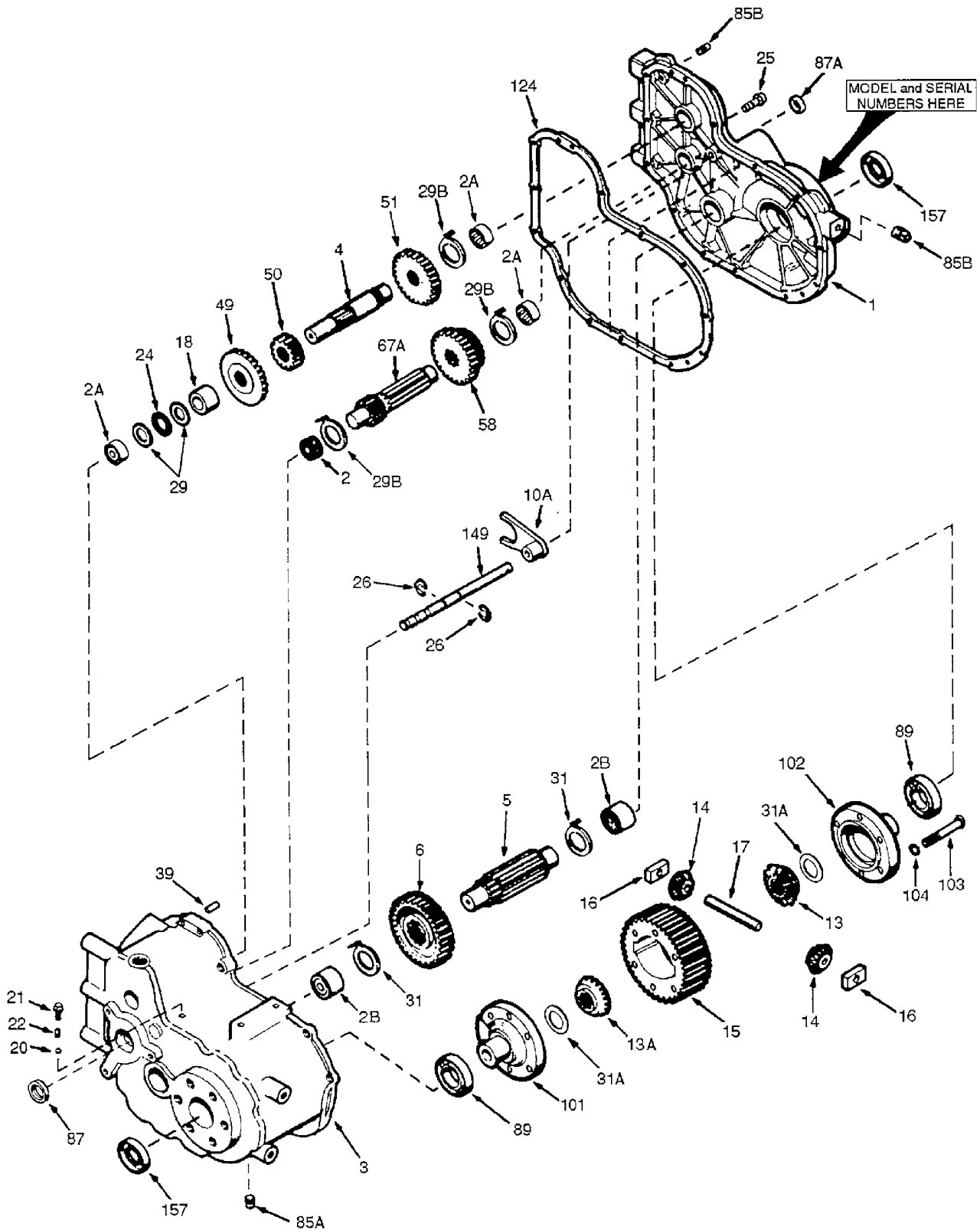

HYDRAULICS, AXLES, & WHEELS

Peerless Transaxle (51.0087)

REF.	PART NO.	DESCRIPTION	QTY.
1	51.0088	.COVER, 2600 TRANSAXLE (Includes 2A & 2B)*	1
2	55.0037	.BEARING, 2600 NEEDLE 1.000 ID	1
2A	55.0038	.BEARING, 2600 NEEDLE 1.000 ID	3
2B	55.0041	.BEARING, 2600 NEEDLE 1.250 ID	2
3	51.0089	.CASE, 2600 TRANSAXLE	1
5	51.0093	.Shaft, Output	1
10A	51.0030	.FORK, 2600 SHIFT	1
13	51.0031	.GEAR, 2600 BEVEL	1
13A	51.0031	.GEAR, 2600 BEVEL	1
14	51.0033	.PINION, 2600 BEVEL	2
24	51.0085	.Bearing, Thrust 1.002 ID x .0781W	1
29	51.0084	.Washer, Thrust 1.002 ID x .061W	2
29B	51.0032	.WASHER, 2600 THRUST	3
31	51.0082	.Washer, Thrust 1.252 ID x .058W	2
31A	51.0028	.WASHER, 2600 THRUST	2
39	51.0029	.PIN, DOWEL 2600 5/16 X 3/4	2
85A	25.6408-H-06	.Fitting, -06 MB x Hollow Allen	1
87	89.0046	.SEAL, BRAKE SHAFT OIL	1
87A	89.0047	.SEAL, SHIFTER ROD OIL	1
89	55.0039	.BEARING, 2600 NEEDLE 1.5743 ID	1
124	89.0051	.GASKET, CASE	1
149	51.0027	.ROD, 2600 SHIFT (HIGH/LOW)	1
157	89.0049	.SEAL, OIL - AXLE PEERLESS	2

Listed items are stocked. Check for availability of unlisted parts.

*Ref. 2 brake shaft bearing must be ordered separately.

HYDRAULICS, AXLES, & WHEELS

ILLUSTRATED DRAWING

Danfoss Hydraulic Motor (21.0149)

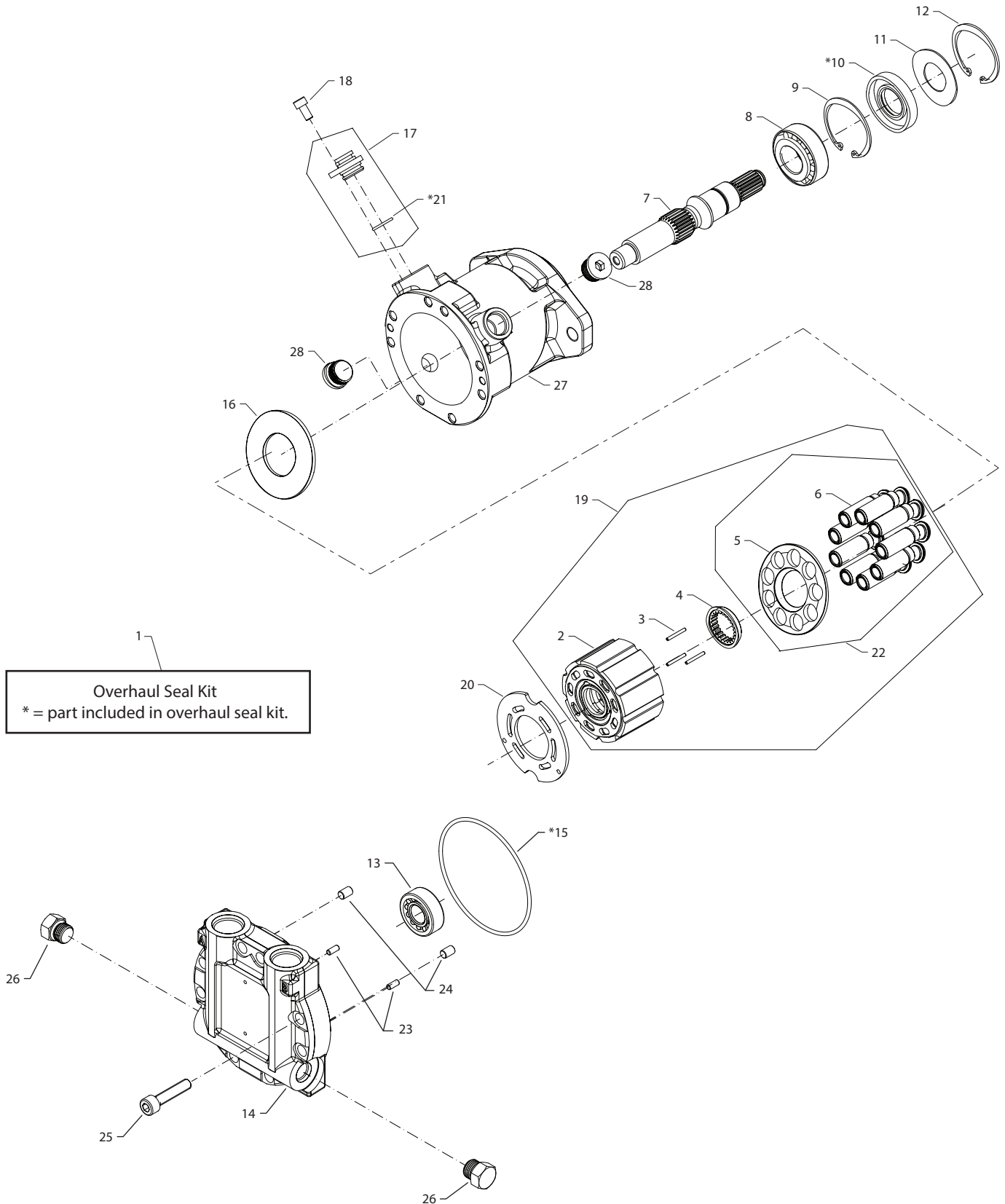

HYDRAULICS, AXLES, & WHEELS

Danfoss Hydraulic Motor (21.0149)

REF.	PART NO.	DESCRIPTION	QTY.
1	89.0115	.Kit, Seal	1
2	21.0166	.Assembly, Cylinder Block PM 20CC	1
3	03.0042	.Pin, Slipper Hold Down	3
4	21.0167	.Guide Ball, 20CC	1
5	21.0168	.Retainer, Slipper	1
6	21.0157	.Assembly, Piston	9
7	21.0169	.Shaft, 17T 24/48	1
8	55.0121	.Bearing, Taper Roller	1
9	04.0056	.Ring, Retaining	1
10	89.0110	.Seal, Lip	1
11	21.0170	.Washer, Support	1
12	04.0055	.Ring, Retaining	1
13	55.0122	.Bearing, Taper Roller	1
14	21.0171	.Cap, End	1
15	26.0008	.O-Ring, .103 x 3.48ID x 3.693OD Viton	1
16	21.0172	.Plate, Thrust	1
17	21.0173	.Plug, PPU H1 Assembly	1
18	99.M0073	.Bolt, M6 x 1.0 x 12 SHCS	1
19	21.0174	.Kit, Cylinder Block	1
20	21.0175	.Valve Plate, Motor	1
21	26.0054	.O-Ring, -016 Viton 80D	1

HYDRAULICS, AXLES, & WHEELS

ILLUSTRATED DRAWING

Danfoss Hydraulic Pump (21.0148)

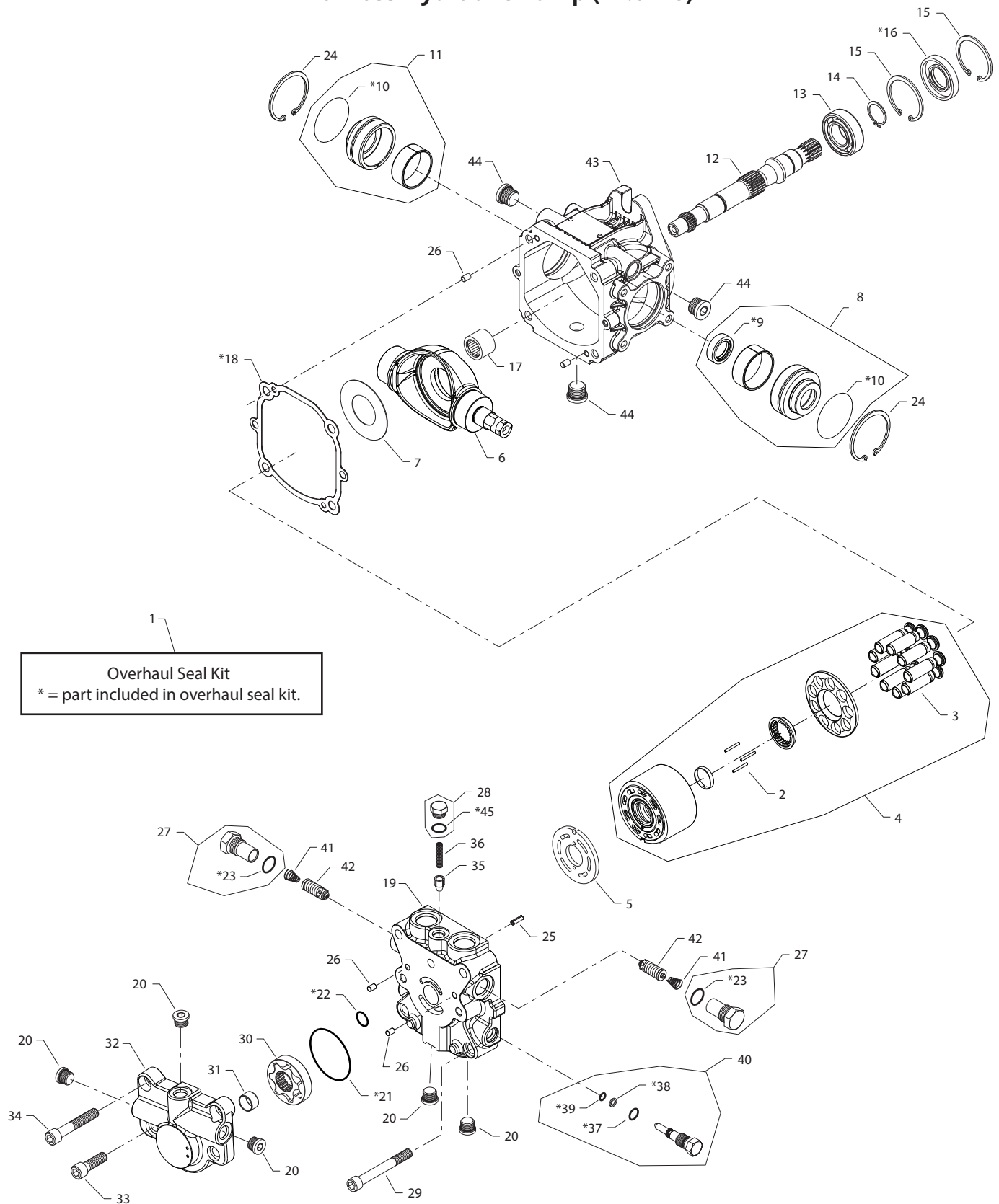

HYDRAULICS, AXLES, & WHEELS

Danfoss Hydraulic Pump (21.0148)

REF.	PART NO.	DESCRIPTION	QTY.
1	89.0114	.Kit, Seal	1
2	03.0042	.Pin, Slipper Hold Down	3
3	21.0157	.Assembly, Piston	9
4	21.0158	.Kit, Cylinder Block	1
5	21.0159	.Valve PLate, Pump	1
6	21.0160	.Swash Plate	1
7	21.0161	.Plate, Thrust	1
8	21.0162	.Assembly, Journal Carrier (B)	1
9	89.0112	.Seal, Lip	1
10	26.0055	.O-Ring, -136 Viton 75 Duro	2
11	21.0163	.Assembly, Journal Carrier (A)	1
12	21.0164	.Shaft, Pump	1
13	55.0119	.Bearing, Ball	1
14	04.0054	.Ring, Retaining	1
15	04.0055	.Ring, Retaining	2
16	89.0113	.Seal, Lip	1
17	55.0120	.Bearing, Needle	1
18	44.0426	.Gasket, Pump	1
19	21.0165	.Cap, End	1
20	51.0068	.Plug, 9/16-18 Metal	5
21	26.0056	.O-ring, -036 Viton 75 Duro	1
22	26.0057	.O-ring, -016 Viton 90 Duro	1
23	26.0037	.O-ring, for Morb-08 Viton	2

HYDRAULICS, AXLES, & WHEELS

ILLUSTRATED DRAWING

2 Spool Valve (23.0201)

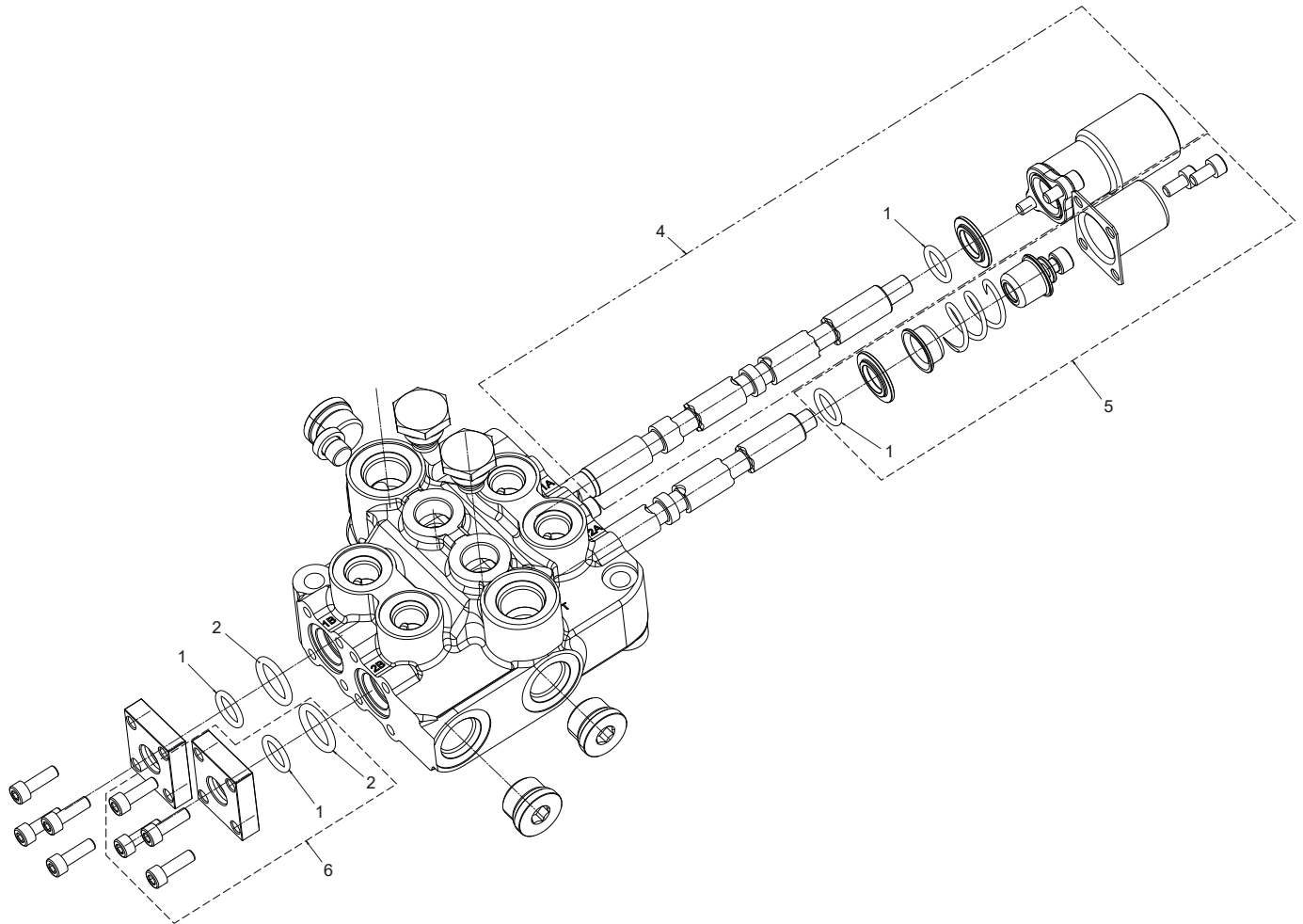

HYDRAULICS, AXLES, & WHEELS

2 Spool Valve (23.0201)

REF.	PART NO.	DESCRIPTION	QTY.
1	89.0111	.Seal, Spool	4
2	26.0058	.O-Ring, 17mm x 3 70 Buna	2
4	23.0212	.Service Kit, 4 Pos Spool W/Detent.	1
5	23.0207	.Kit, 3 Position Spring Actuator	1
6	23.0208	.Kit, Handle Bracket 2-Spool	2

HYDRAULICS, AXLES, & WHEELS

ILLUSTRATED DRAWING

3 Spool Valve (23.0202)

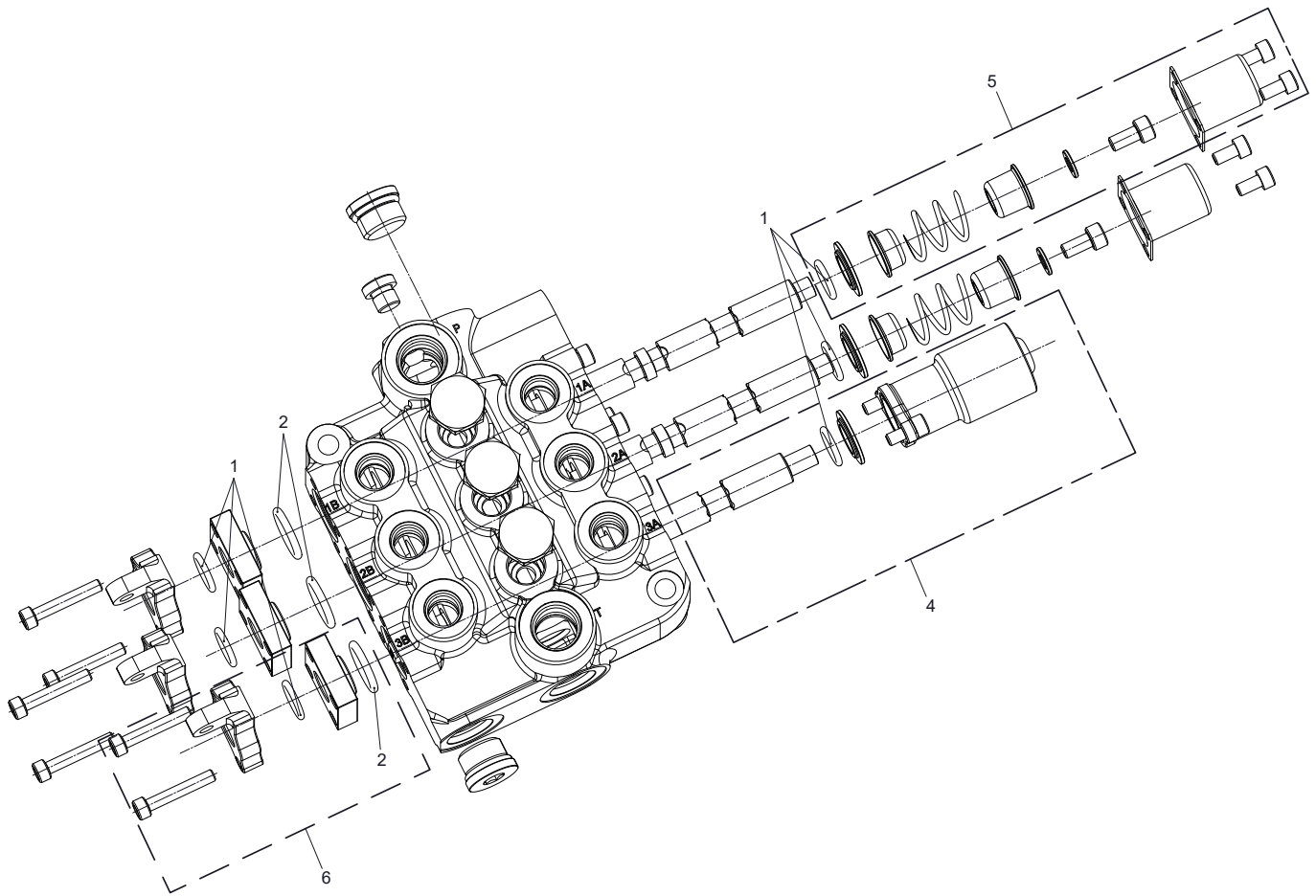

HYDRAULICS, AXLES, & WHEELS

3 Spool Valve (23.0202)

REF.	PART NO.	DESCRIPTION	QTY.
1	89.0111	Seal, Spool	6
2	26.0058	O-Ring, 17mm x 3 70 D Buna	3
4	23.0212	Service Kit, 4 Pos Spool W/Detent.	1
5	23.0207	Kit, 3 Position Spring Actuator	2
6	23.0209	Service Kit - Handle Bracket 3-Spool	3

ENGINE

ILLUSTRATED DRAWING

4520Y Kubota Diesel Engine (Serial # 01001-05664)

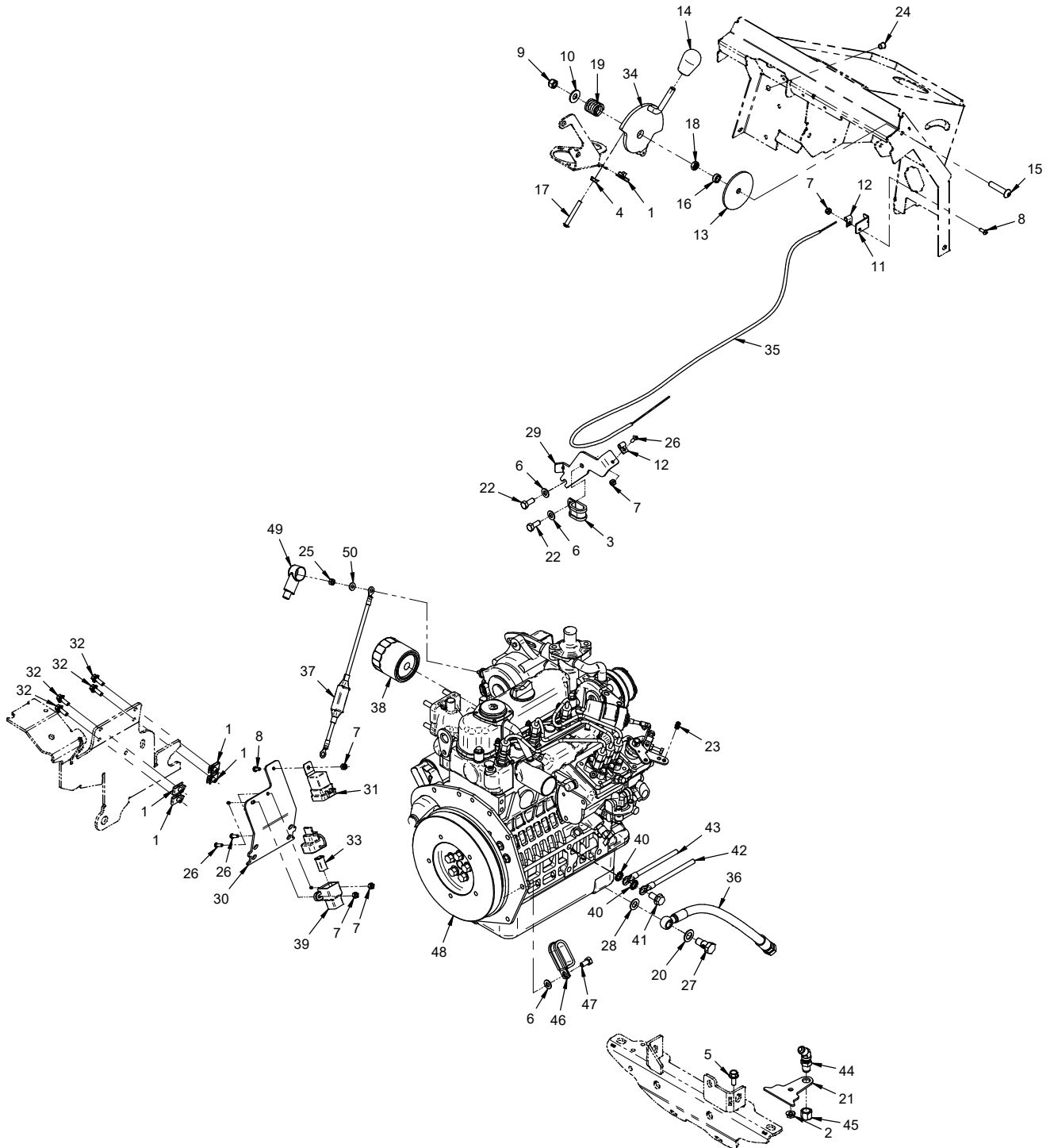

ENGINE

4520Y Kubota Diesel Engine (Serial # 01001-05664)

REF.	PART NO.	DESCRIPTION	QTY.
1	99.E0046	Nut, "U" 1/4-20 Extruded	5
2	99.SF05	Nut, SRF 5/16-18 USS	1
3	11.0046	Clamp, Cushioned 1/2" 2-Tube	1
4	99.SF04	Nut, SRF 1/4-20 USS	1
5	99.SF0506-1	Bolt, SMF 5/16-18 USS x 3/4	1
6	95.05	Washer, Flat 5/16 SAE	3
7	99.A1032N	Locknut, Nylon 10-32 Stainless	5
8	99.K0062	Machine Screw, #10-32 X 1/2	2
9	99.A06N	Locknut, Nylon 3/8-16	1
10	94.06	Washer, Flat 3/8 USS	1
11	64.1700	Bracket, Cable End	1
12	45.0050	Clamp, Cable	2
13	05.0013	Washer, Fric. 3 OD x 13/32 ID	1
14	47.0001	Knob, Sm. #80 3/8-16 Thread	1
15	99.0614	Bolt, 3/8-16 x 1-3/4 BSCS	1
16	64.0602	Bushing, 3/8 x 5/8 x .265	1
17	99.0416	Bolt, 1/4-20 x 2 BSCS	1
18	99.E0113	Nut, Jam 3/8-16 Nylon Lock GR8	1
19	41.0107	Spring, Comp. .970" OD x 1" LG	1
20	99.B0106	Washer, Sealing 14mm Copper	1
21	KN-1087	Mount, Oil Drain Hose	1
22	99.M0005	Bolt, M8 X 1.25 P X 20MM	2
23	47.0234	Throttle Control, Wire Swivel	1
24	05.0087	Plug, 3/8" Hole, Black	1
25	99.M0031	Nut, M6 X 1.00	1
26	99.K0071	Machine Screw, #10-32 x 5/8	3
27	14.0051	Bolt, Banjo M12 x 1.25	1
28	99.B0108	Washer, Sealing 12mm Copper	1
29	64.1692	Bracket, Throttle Cable	1
30	64.1693	This part is not released	1
31	35.0122	Relay, 12V 20/40A Mini Sealed	1
32	99.SF0406	Bolt, SRF 1/4-20 X 3/4	4
33	30.0374	Fuse, 50A J-Case Orange	1
34	40.0377	Lever, Throttle	1
35	47.0322	Cable, Throttle KN	1
36	22.0062	Oil Drain Hose for 4500Y	1
37	30.0451	Fuse, 80 Amp Fuse Link	1
38	13.0267	Filter, Engine Oil Kubota	1
39	30.0402	Fuse Holder, 50A J Case	1
40	99.G0004	Washer, Star-External 3/8	2
41	99.M0028	Bolt, M10-1.25 X 20MM Flange	1
42	32.0103	Cable, Negative KN Dummy	1
43	32.0112	Cable, Negative KN Dummy	1
44	25.2702-06-06LN	Fitting, Bulkhead 3/8 W/LN 45	1
45	25.304-C-06	Fitting, Cap 3/8 #6 JIC	1
46	11.0071	Clamp, Cushioned Metal 3/4" 2-Tube	1
47	99.M0014	Bolt, M8 x 1.25 x 16mm	1
48	13.0242	Engine, Kubota 25 HP DSL LC	1
49	30.0321	Insulator, Alternator Post	1
50	99.B0051	Washer, Flat #10	1

ENGINE

ILLUSTRATED DRAWING 4520Y Kubota Diesel Engine (Serial # 05665-)

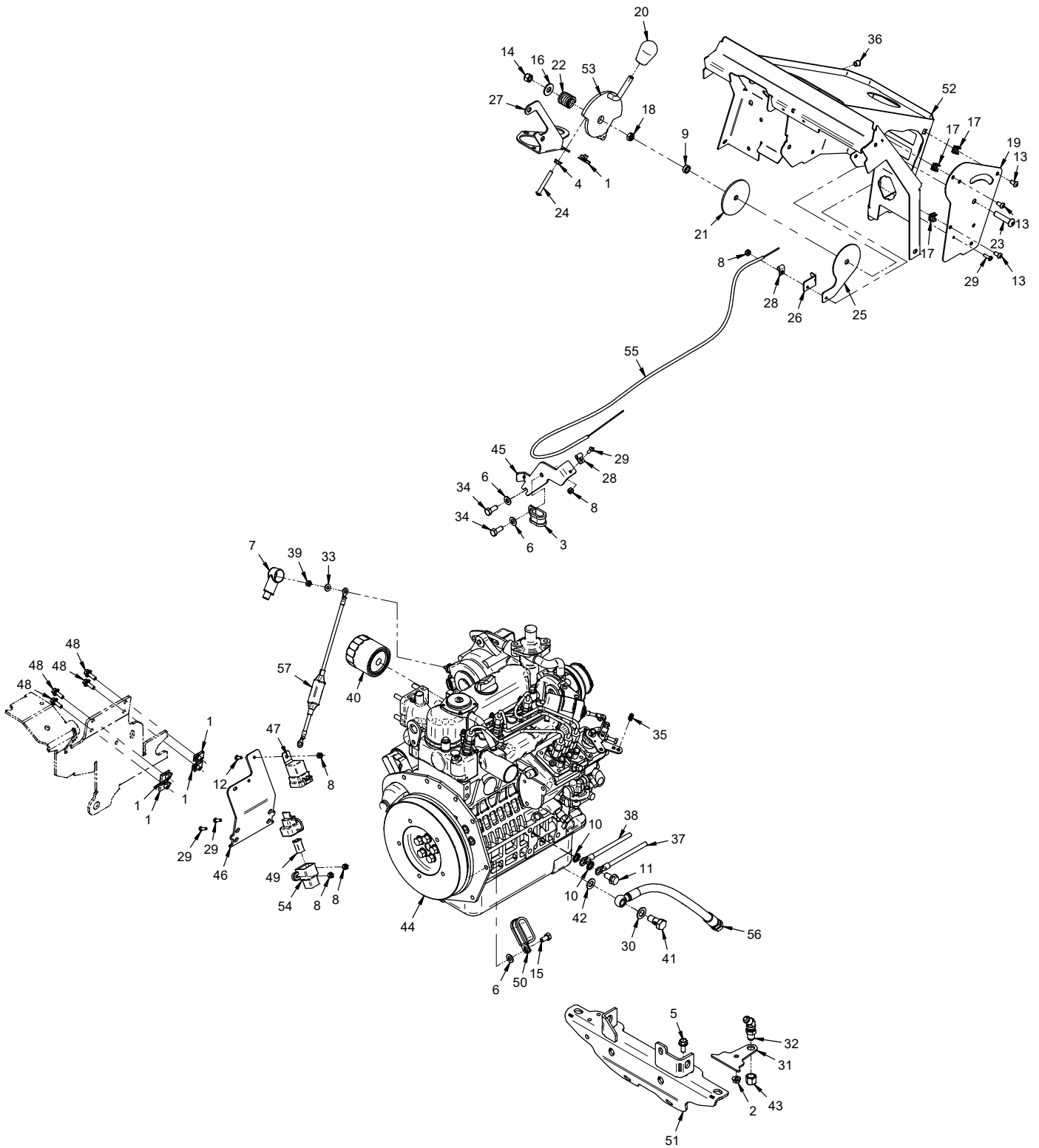

ENGINE

4520Y Kubota Diesel Engine (Serial # 05665-)

REF.	PART NO.	DESCRIPTION	QTY.
1	99.E0046	Nut, "U" 1/4-20 Extruded	5
2	99.SF05	Nut, SRF 5/16-18 USS	1
3	11.0046	Clamp, Cushioned 1/2" 2-Tube	1
4	99.SF04	Nut, SRF 1/4-20 USS	1
5	99.SF0506-1	Bolt, SMF 5/16-18 USS x 3/4	1
6	95.05	Washer, Flat 5/16 SAE	3
7	30.0321	Insulator, Alternator Post	1
8	99.A1032N	Locknut, Nylon 10-32 Stainless	5
9	64.0602	Bushing, 3/8 x 5/8 x .265	1
10	99.G0004	Washer, Star-External 3/8	2
11	99.M0028	Bolt, M10-1.25 X 20MM Flange	2
12	99.K0062	Machine Screw, #10-32 X 1/2	1
13	99.0404	Bolt, 1/4-20 x 1/2 BSCS	3
14	99.A06N	Locknut, Nylon 3/8-16	1
15	99.M0014	Bolt, M8 x 1.25 x 16mm	1
16	94.06	Washer, Flat 3/8 USS	1
17	99.E0146	Nut, Cage 1/4-20 (.093 - .126")	3
18	99.E0113	Nut, Jam 3/8-16 Nylon Lock GR8	1
19	KN-1396	Panel, Throttle	1
20	47.0001	Knob, Sm. #80 3/8-16 Thread	1
21	05.0013	Washer, Fric. 3 OD x 13/32 ID	1
22	41.0107	Spring, Comp. .970" OD x 1" LG	1
23	99.0614	Bolt, 3/8-16 x 1-3/4 BSCS	1
24	99.0416	Bolt, 1/4-20 x 2 BSCS	1
25	KN-1404	Plate, Spacer Mech Throttle	1
26	64.1700	Bracket, Cable End	1
27	64.1691	Bracket, Harness Connector	1
28	45.0050	Clamp, Cable	2
29	99.K0071	Machine Screw, #10-32 x 5/8	4
30	99.B0106	Washer, Sealing 14mm Copper	1
31	KN-1087	Mount, Oil Drain Hose	1
32	25.2702-06-06LN	Fitting, Bulkhead 3/8 W/LN 45	1
33	99.B0051	Washer, Flat #10	1
34	99.M0005	Bolt, M8 X 1.25 P X 20MM	2
35	47.0234	Throttle Control, Wire Swivel	1
36	05.0087	Plug, 3/8" Hole, Black	1
37	32.0103	Cable, Negative KN Dummy	1
38	32.0112	Cable, Negative KN Dummy	1
39	99.M0031	Nut, M6 X 1.00	1
40	13.0267	Filter, Engine Oil Kubota	1
41	14.0051	Bolt, Banjo M12 x 1.25	1
42	99.B0108	Washer, Sealing 12mm Copper	1
43	25.304-C-06	Fitting, Cap 3/8 #6 JIC	1
44	13.0242	Engine, Kubota 25 HP DSL LC	1
45	64.1692	Bracket, Throttle Cable	1
46	64.1693	This part is not released.	1
47	35.0122	Relay, 12V 20/40A Mini Sealed	1
48	99.SF0406	Bolt, SRF 1/4-20 X 3/4	4
49	30.0374	Fuse, 50A J-Case Orange	1
50	11.0071	Clamp, Cushioned Metal 3/4" 2-Tube	1
51	KN-6013	Bracket, Connector Frame MT	1
52	KN-6062	Dash, Main Panel	1
53	40.0377	Lever, Throttle	1
54	30.0402	Fuse Holder, 50A J Case	1
55	47.0322	Cable, Throttle KN	1
56	22.0062	Hose, 3/8x13.50 PLK 250 PSI CPE	1
57	30.0451	Fuse, 80 Amp Fuse Link (Serial # 01001-05814)	1
57	30.0599	Fuse Holder, w/80A Inline Maxi Fuse (Serial # 05815-)	1

ENGINE

4520Y Kubota Diesel Engine Mount

REF.	PART NO.	DESCRIPTION	QTY.
1	99.E0046	.Nut, "U" 1/4-20 Extruded	14
2	99.SF0404-1	.Bolt, SMF 1/4-20 X 1/2.	1
3	99.SF04	.Nut, SRF 1/4-20 USS	1
4	99.SF0405-1	.Bolt, SMF 1/4-20 X 5/8.	10
5	99.SF0406-1	.Bolt, SMF 1/4-20 X 3/4.	4
6	64.2007	.Mount, Engine Kubota Rear	1
7	05.0088	.Isolator, 3/8-16 X 2.5 OD X 1"	2
8	99.B0076	.Washer, .130T x .395ID x 1.5OD	2
9	95.06	.Washer, Flat 3/8 SAE	2
10	99.A06N	.Locknut, Nylon 3/8-16.	4
11	05.0183	.Isolator, 1/2 Id x 1.88 OD x 2 Piece	2
12	94.08	.Washer, Flat 1/2 USS	2
13	90.0824	.Bolt, 1/2-13 USS x 3	2
14	99.A08N	.Locknut, Nylon 1/2-13 USS	2
15	99.M0028	.Bolt, M10-1.25 X 20MM Flange	10
16	64.1685	.Bracket, Engine Electrical	1
17	60.1165	.Cover, Kubota Timer	1
18	99.SF0608-1	.Bolt, SMF 3/8-16 x 1	6
19	KN-1077	.Cover, Engine Right	1
20	KN-6014	.Cover, Engine Left (Serial # 01001-08723)	1
21	99.SF06	.Nut, SRF 3/8-16 USS	6
22	05.0036	.Grommet, 1 1/2Id,2 1/8Od,9/16T	1
23	13.1J321-60242	.Timer, Key Stop	1
24	64.2006	.Mount, Engine Kubota Right	1
25	64.2005	.Mount, Engine Kubota Left	1
30*	99.E0157	.Receptacle, Fast Lead Screw (Serial # 08724-)	1
31*	99.E0156	.Retainer, Fast Lead Screw (Serial # 08724-)	1
32*	99.K0184	.Screw, Captive Fast Lead (Serial # 08724-)	1
33*	KN-1460	.Cover, Engine Left (Serial # 08724-)	1
34*	KN-1461	.Panel, Access Left (Serial # 08724-)	1

*Note: 70.4197 Kubota Left Side Engine Kit, (Serial # 08724-) includes items 30 through 34.

ENGINE

ILLUSTRATED DRAWING

4520Y Kubota Diesel PTO Clutch

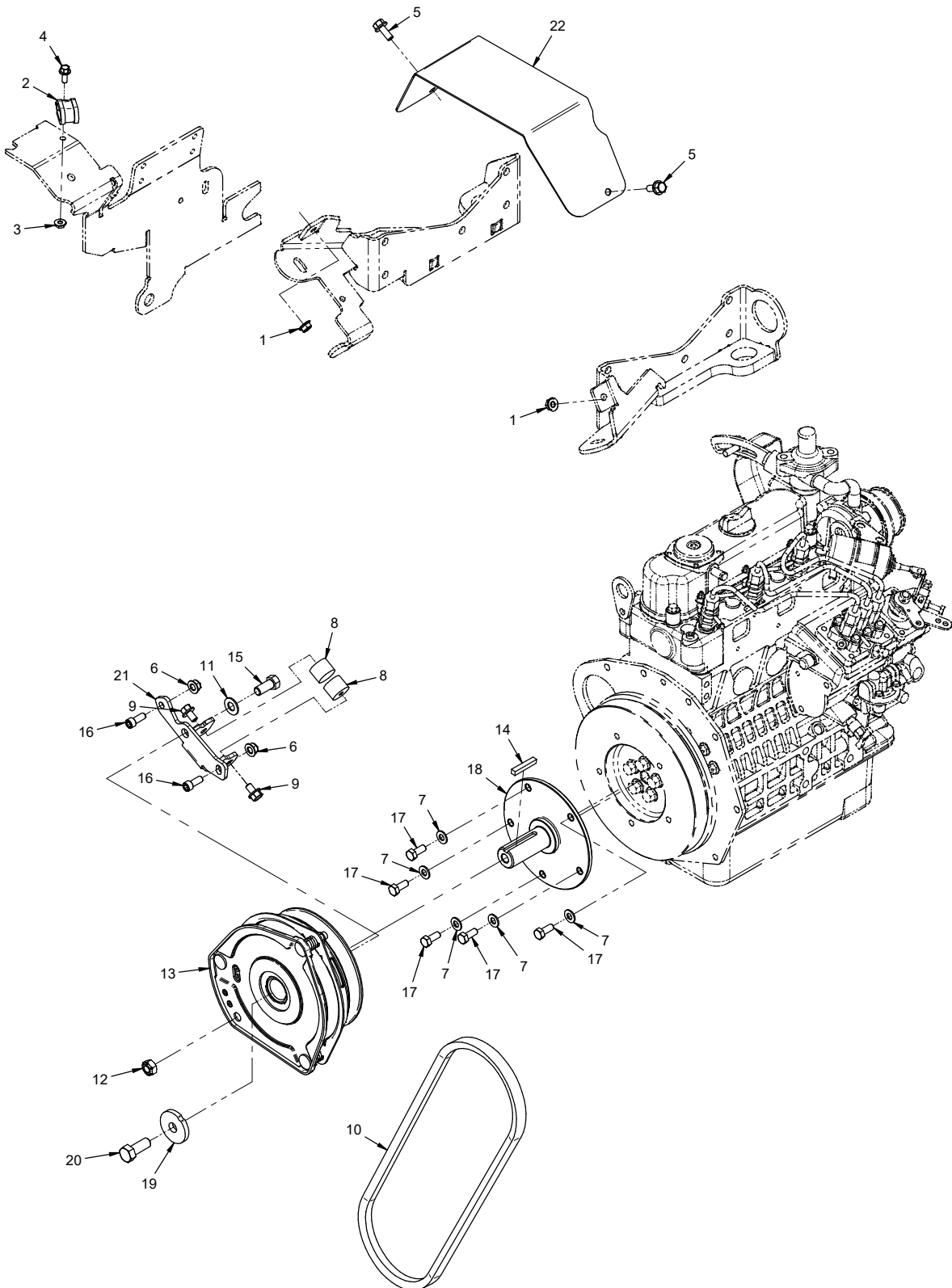

ENGINE

4520Y Kubota Diesel PTO Clutch

REF.	PART NO.	DESCRIPTION	QTY.
1	99.SF05	Nut, SRF 5/16-18 USS	2
2	11.0046	Clamp, Cushioned 1/2" 2-Tube	1
3	99.SF04	Nut, SRF 1/4-20 USS	1
4	99.SF0405-1	Bolt, SMF 1/4-20 X 5/8	1
5	99.SF0506-1	Bolt, SMF 5/16-18 USS x 3/4	2
6	99.E0102	Nut, Locking Flange 5/16-18	2
7	95.05	Washer, Flat 5/16 SAE	5
8	05.0110	Bumper, Neoprene 1" Dia	2
9	99.SF0504-1	Bolt, SMF 5/16-18 USS x 1/2	2
10	81.B038	Belt, B38	1
11	95.07	Washer, Flat 7/16 SAE	1
12	99.A07	Locknut, Stover 7/16-14 USS	1
13	37.0060	Clutch, Electric Ogura GT3.5	1
14	85.K0412	Key, 1/4 X 1-1/2	1
15	90.0708	Bolt, 7/16-14 USS x 1	1
16	99.K0134	Bolt, SHCS 5/16-18 x 3/4	2
17	99.M0005	Bolt, M8 X 1.25 P X 20MM	5
18	13.0257	Stub Shaft, Kubota KN	1
19	99.B0064	Washer, 1/4 x 1.75 x .531 Hole	1
20	91.0810	Bolt, 1/2-20 SAE x 1 1/4	1
21	64.1697	Bracket, Clutch Torque	1
22	60.1166	Cover, Flywheel	1

ENGINE

ILLUSTRATED DRAWING

4520Y Kubota Diesel Drive Shaft

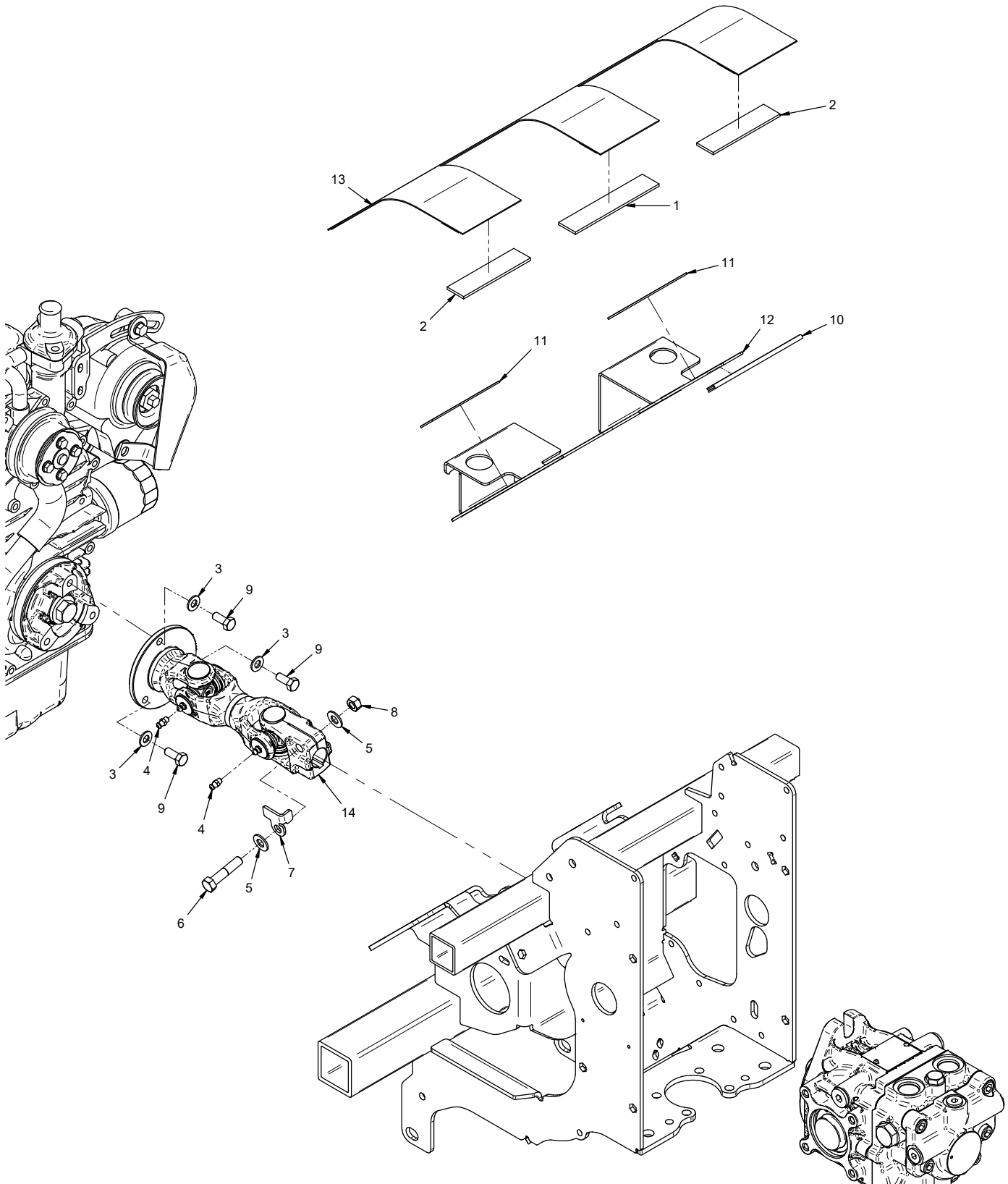

ENGINE

4520Y Kubota Diesel Drive Shaft

REF.	PART NO.	DESCRIPTION	QTY.
1	06.0065-5IN	Velcro, Loop 1" Black x 5"	1
2	06.0065-4IN	Velcro, Loop 1" Black x 4"	2
3	95.05	Washer, Flat 5/16 SAE	3
4	29.GF0001	Grease Ftg, 1/4 SAE ST	2
5	95.06	Washer, Flat 3/8 SAE	2
6	90.0614	Bolt, 3/8-16 USS x 1-3/4	1
7	64.1654	Plate, Driveshaft Tach Trigger	1
8	99.A06	Locknut, Stover 3/8-16 USS	1
9	99.M0005	Bolt, M8 X 1.25 P X 20MM	3
10	06.0042-5IN	Trim, Trim Loc 1/2 x 1/16	1
11	06.0065-5IN	Velcro, Loop 1" Black	2
12	KN-1237	Bracket, Radiator Mount Bottom	1
13	44.0420	Canvas, Debris Barrier	1
14	87.0257	U-Joint, KN4520 Y & Z	1

ENGINE

ILLUSTRATED DRAWING 4520Y Kubota Diesel Muffler

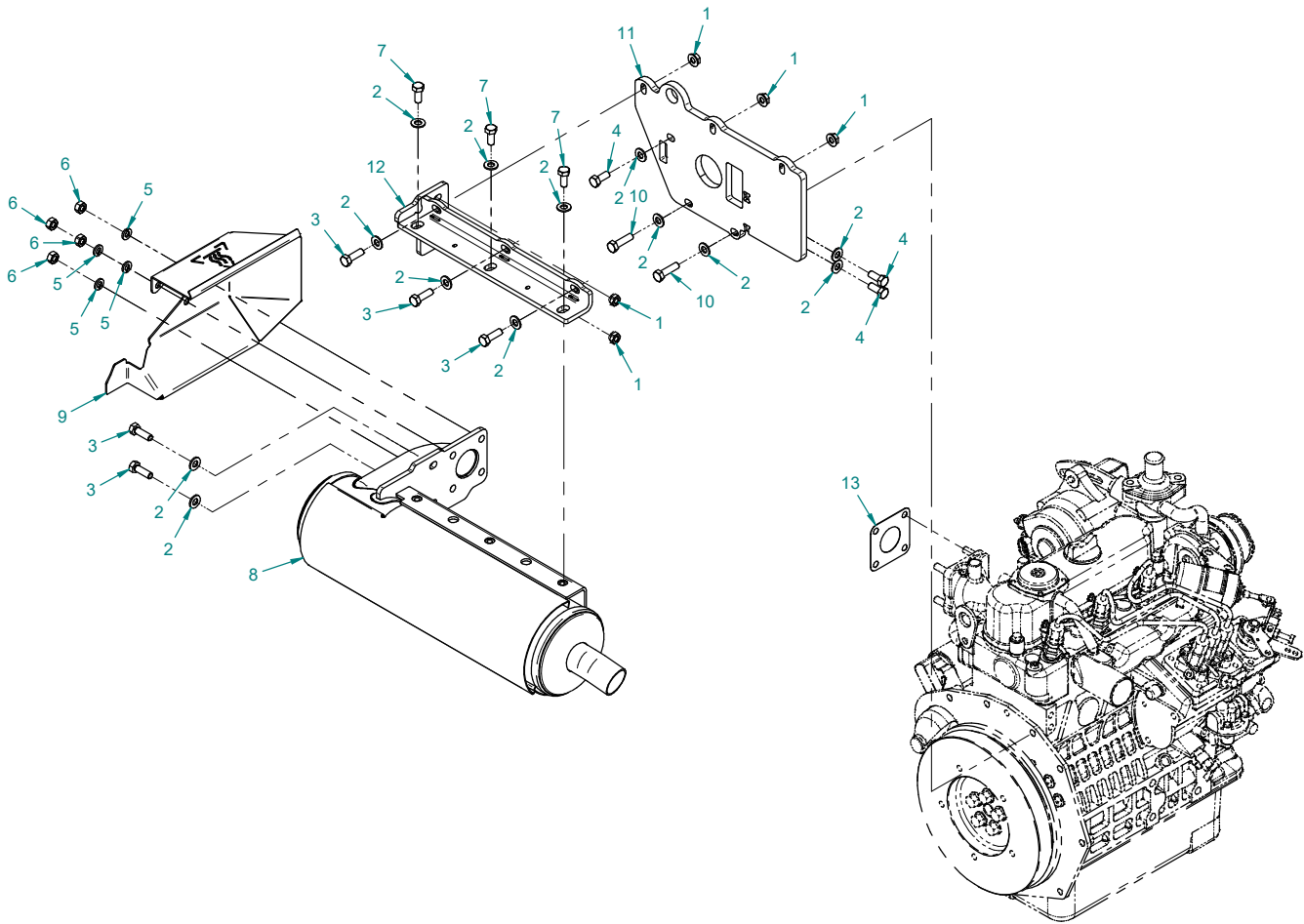

ENGINE

4520Y Kubota Diesel Muffler

REF.	PART NO.	DESCRIPTION	QTY.
1	99.SF05	Nut, SRF 5/16-18 USS	5
2	95.05	Washer, Flat 5/16 SAE	13
3	90.0508	Bolt, 5/16-18 USS x 1	5
4	99.M0005	Bolt, M8 X 1.25 P X 20MM	3
5	96.05	Washer, Lock 5/16	4
6	99.M0008	Nut, M8 x 1.25MM ZP	4
7	90.0506	Bolt, 5/16-18 USS x 3/4"	3
8	13.0342	Muffler, Kubota 25HP DSL	1
9	60.1164-1	Shield, Exhaust Manifold	1
10	99.M0032	Bolt, M8 X 1.25 X 30MM	2
11	64.1743	Mount, Muffler	1
12	64.1744	Bracket, Muffler Mount	1
13	13.15263-12371	Gasket, Muffler	1

ENGINE

ILLUSTRATED DRAWING

4520Y Kubota Diesel Cooling System (Serial # 01001-05576)

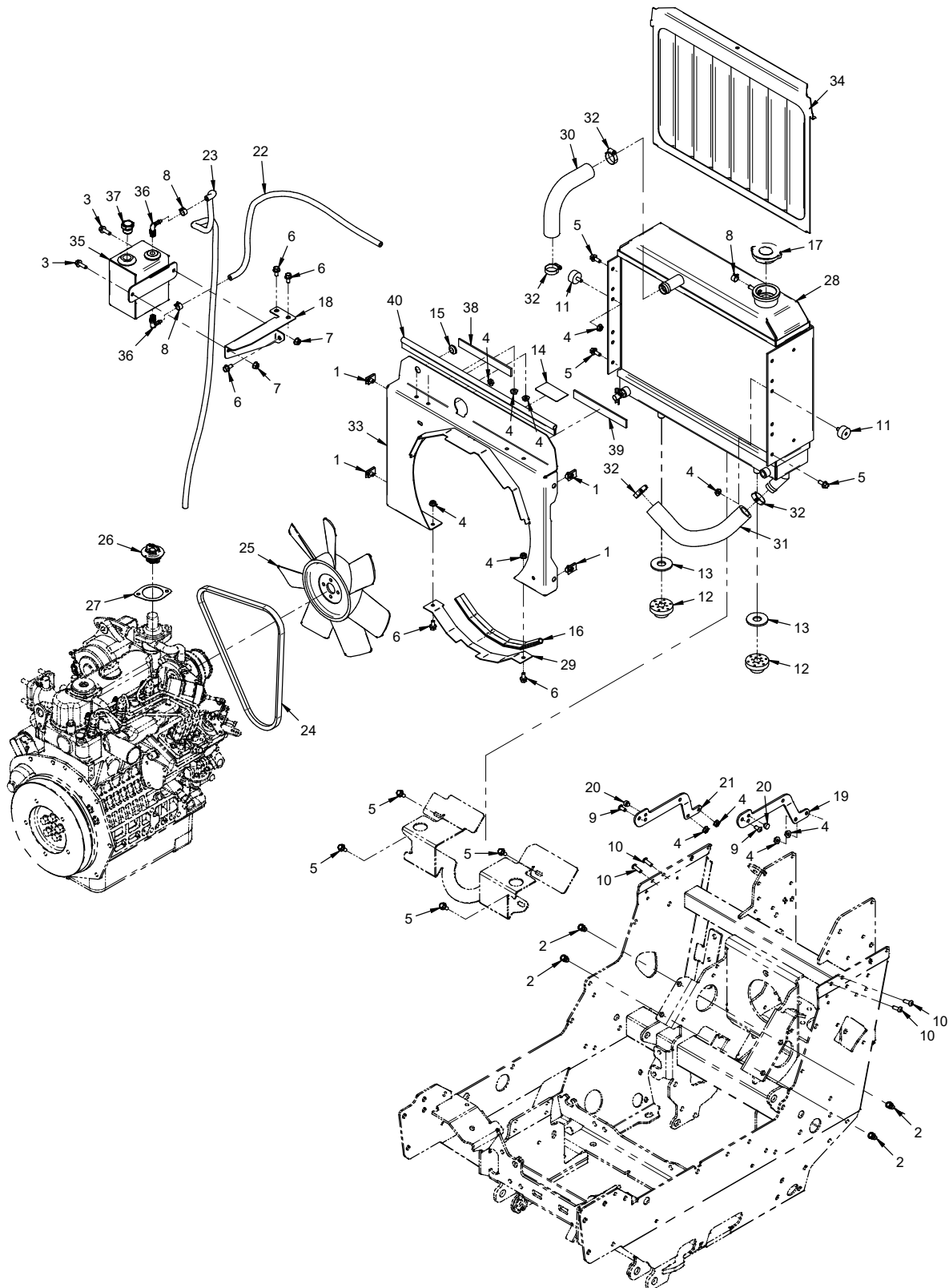

ENGINE

4520Y Kubota Diesel Cooling System (Serial # 01001-05576)

REF.	PART NO.	DESCRIPTION	QTY.
1	99.E0046	Nut, "U" 1/4-20 Extruded	4
2	99.E0105	Nut, Insert 1/4-20 Hex	4
3	99.SF0406-1	Bolt, SMF 1/4-20 X 3/4	2
4	99.SF04	Nut, SRF 1/4-20 USS	11
5	99.SF0405-1	Bolt, SMF 1/4-20 X 5/8	7
6	99.SF0404-1	Bolt, SMF 1/4-20 X 1/2	5
7	99.E0101	Nut, Locking Flange 1/4-20	2
8	11.0049	Clamp, Hose Band 1/2" OD Hose	3
9	99.0404	Bolt, 1/4-20 x 1/2 BSCS	2
10	99.0406	Bolt, 1/4-20 x 3/4 BSCS	4
11	05.0135	Isolator, 1/4-20 x 1/2 x 1" F/M	2
12	05.0107	Isolator, 9/16 ID X 1-29/32 OD	2
13	94.10	Washer, Flat 5/8 USS	2
14	00.0638	Decal, Fan Blade Hazard	1
15	05.0136	Grommet, 7/16ID, 3/4OD, 1/4Thk	1
16	06.0043-10IN	Trim, Trim Seal W/ Bulb x 10"	1
17	47.0334	Cap, Radiator 14#	1
18	64.1640	Bracket, Coolant Recovery Tank	1
19	64.1642	Bracket, Radiator Mount Left	1
20	05.0120	Bumper, Neoprene 10 Ga - 1/4	2
21	64.1629	Bracket, Radiator Mount Right	1
22	27.A04-21IN	Hose, Neop Black 1/4 x 7/16 x 21"	1
23	27.A04-36IN	Hose, Neop Black 1/4 x 7/16 x 36"	1
24	13.17472-97010	V Belt, FM35.0 In	1
25	13.17525-74111	Fan, Cooling 310MM Suction	1
26	13.15321-73016	Thermostat, 180A° Kubota	1
27	13.16221-73270	Gasket, Thermostat	1
28	47.0302	Radiator, KN Kubota	1
29	64.1622	Bracket, Radiator Shroud	1
30	13.0262	Hose, Radiator Upper Kubota	1
31	13.0263	Hose, Radiator Lower Kubota	1
32	11.0052	Clamp, Hose Ss 13/16 X 1-1/2	4
33	KN-6012	Shroud, Radiator - 47.0302	1
34	64.1620	Screen, Radiator - 47.0302	1
35	KN-6057	Tank, Coolant Recovery	1
36	29.BF04MP0290-N	FITTING, NYLN 1/4BRB X 1/8MP 90	2
37	25.6408-08	Fitting, Plug 8MB	1
38	06.0045-6IN	Weatherstrip, 1/8 x 3/4 x 6"	1
39	06.0045-10IN	Weatherstrip, 1/8 x 3/4 x 10"	1
40	06.0043-17.5IN	Trim, Trim Seal W/Bulb-17.5"	1

ENGINE

ILLUSTRATED DRAWING

4520Y Kubota Diesel Cooling System (Serial # 05577-)

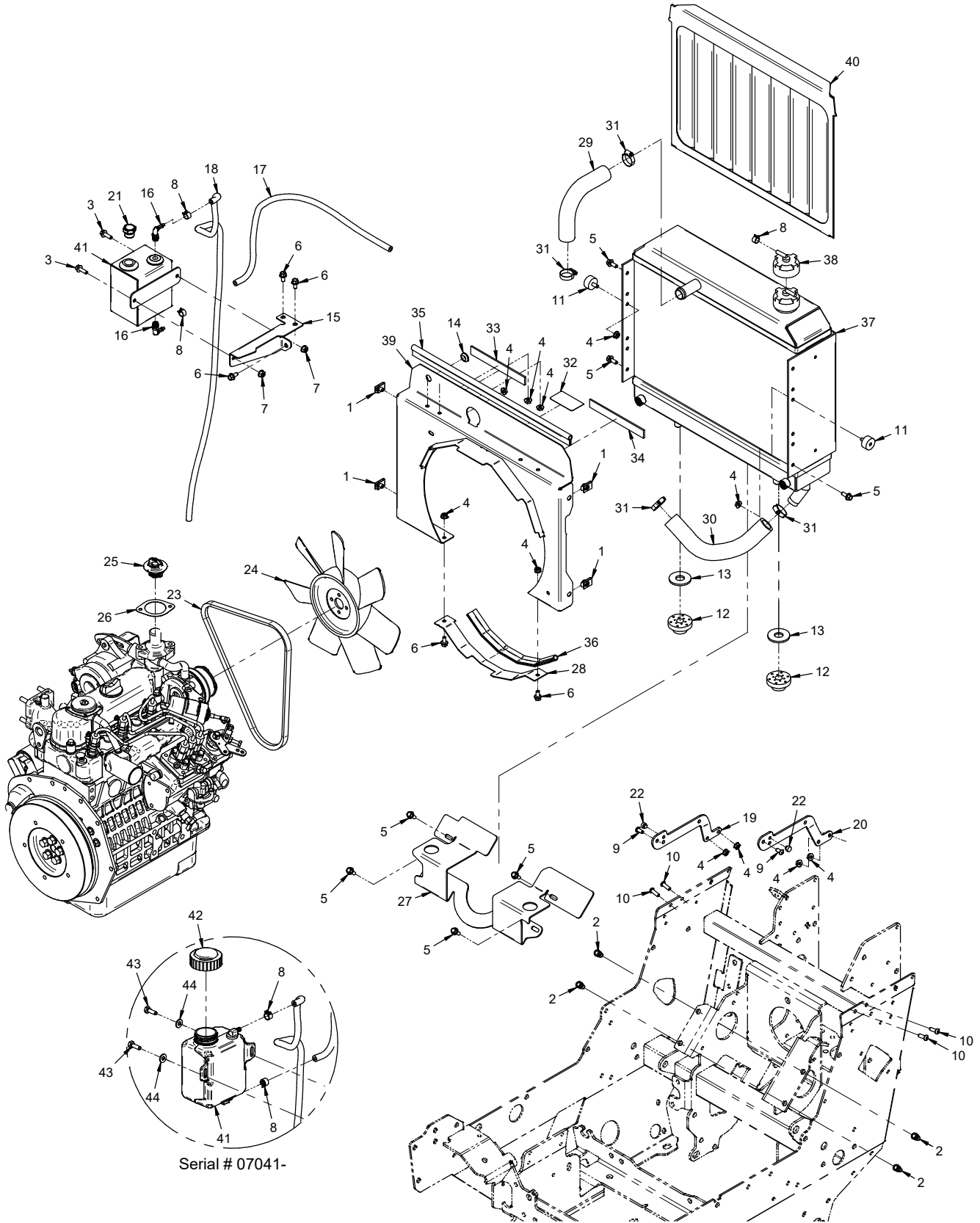

ENGINE

4520Y Kubota Diesel Cooling System (Serial # 05577-)

REF.	PART NO.	DESCRIPTION	QTY.
1	99.E0046	Nut, "U" 1/4-20 Extruded	4
2	99.E0105	Nut, Insert 1/4-20 Hex	4
3	99.SF0406-1	Bolt, SMF 1/4-20 X 3/4 (Serial # 01001-07040)	2
4	99.SF04	Nut, SRF 1/4-20 USS	11
5	99.SF0405-1	Bolt, SMF 1/4-20 X 5/8	7
6	99.SF0404-1	Bolt, SMF 1/4-20 X 1/2	5
7	99.E0101	Nut, Locking Flange 1/4-20	2
8	11.0049	Clamp, Hose Band 1/2" OD Hose	3
9	99.0404	Bolt, 1/4-20 x 1/2 BSCS	2
10	99.0406	Bolt, 1/4-20 x 3/4 BSCS	4
11	05.0135	Isolator, 1/4-20 x 1/2 x 1" F/M	2
12	05.0107	Isolator, 9/16 ID X 1-29/32 OD	2
13	94.10	Washer, Flat 5/8 USS	2
14	05.0136	Grommet, 7/16ID, 3/4OD, 1/4Thk	1
15	64.1640	Bracket, Coolant Recovery Tank	1
16	29.BF04MP0290-N	FITTING, NYLN 1/4BRB X 1/8MP 90	2
17	27.A04-21IN	Hose, Neop Black 1/4 x 7/16 x 21"	1
18	27.A04-36IN	Hose, Neop Black 1/4 x 7/16 x 36"	1
19	64.1629	Bracket, Radiator Mount Right	1
20	64.1642	Bracket, Radiator Mount Left	1
21	25.6408-08	Fitting, Plug 8MB (Serial # 01001-07040)	1
22	05.0120	Bumper, Neoprene 10 Ga - 1/4	2
23	13.17472-97010	V Belt, FM35.0 In	1
24	13.17525-74111	Fan, Cooling 310MM Suction	1
25	13.15321-73016	Thermostat, 180A° Kubota	1
26	13.16221-73270	Gasket, Thermostat	1
27	KN-1237	Bracket, Radiator Mount Bottom	1
28	64.1622	Bracket, Radiator Shroud	1
29	13.0262	Hose, Radiator Upper Kubota	1
30	13.0263	Hose, Radiator Lower Kubota	1
31	11.0052	Clamp, Hose Ss 13/16 X 1-1/2	4
32	00.0638	Decal, Fan Blade Hazard	1
33	06.0045-6IN	Weatherstrip, 1/8 x 3/4 x 6"	1
34	06.0045-10IN	Weatherstrip, 1/8 x 3/4 x 10"	1
35	06.0043-17.5IN	Trim, Trim Seal W/Bulb-17.5"	1
36	06.0043-10IN	Trim, Trim Seal W/ Bulb x 10"	1
37	47.0515	RADIATOR, KN KUBOTA	1
38	47.0516	Cap, Radiator 14#, Plastic	1
39	KN-6012	Shroud, Radiator - 47.0302	1
40	64.1620	Screen, Radiator - 47.0302	1
41	KN-6057	Tank, Coolant Recovery (Serial # 01001-07040)	1
41	47.0317	Tank, Coolant Recovery (Serial # 07041-)	1
42	47.0319	Cap, Coolant Recovery Tank (Serial # 07041-)	1
43	90.0406	Bolt, 1/4-20 USS x 3/4 (Serial # 07041-)	2
44	95.04	Washer, Flat 1/4 SAE (Serial # 07041-)	2

ENGINE

4520Y Kubota Diesel Air Intake

REF.	PART NO.	DESCRIPTION	QTY.
1	99.E0046	Nut, "U" 1/4-20 Extruded	3
2	99.SF05	Nut, SRF 5/16-18 USS	4
3	99.SF04	Nut, SRF 1/4-20 USS	1
4	99.SF0506-1	Bolt, SMF 5/16-18 USS x 3/4	2
5	99.SF0508-1	Bolt, SMF 5/16-18 x 1	2
6	99.SF0404-1	Bolt, SMF 1/4-20 X 1/2	1
7	99.0406	Bolt, 1/4-20 x 3/4 BSCS	3
8	13.0231	Clamp, Air Filter 5" Plastic	1
9	14.0026-5	Hose, 2" X 2-3/8 OD Rubber	1
10	64.1643	Bracket, Air Filter Mount	1
11	11.0044	Clamp, Hose S/S 1-9/16- 2-1/2	2
12	13.0274	Hose, Intake 4500Y	1
13	KN-1122	Baffle, Air Inlet	1
14	KN-1121	Cover, Air Inlet	1
15	11.0043	Clamp, Hose SS 1-5/16 To 2-1/4	1
16	13.809670	Cleaner, Air Asm	1
17	05.0120	Bumper, Neoprene 10 Ga - 1/4	2
30	13.533761	Cover Assembly W/ Latches	1
31	13.538928	Latch	2
32	13.0061	Filter, Air-Element Safety	1
33	13.0060	Filter, Air-Element Primary	1
34	13.522958	Valve, Drain	1

ENGINE

4520Y Kubota Diesel Fuel System

REF.	PART NO.	DESCRIPTION	QTY.
1	99.E0046	Nut, "U" 1/4-20 Extruded	1
2	99.SF05	Nut, SRF 5/16-18 USS	2
3	99.SF0406-1	Bolt, SMF 1/4-20 X 3/4	1
4	11.0046	Clamp, Cushioned 1/2" 2-Tube	1
5	99.SF04	Nut, SRF 1/4-20 USS	4
6	99.SF0508-1	Bolt, SMF 5/16-18 x 1	2
7	99.SF0404-1	Bolt, SMF 1/4-20 X 1/2	3
8	95.05	Washer, Flat 5/16 SAE	2
9	99.SF0404	Bolt, SRF 1/4-20 X 1/2	1
10	99.M0014	Bolt, M8 x 1.25 x 16mm	1
11	99.0406	Bolt, 1/4-20 x 3/4 BSCS	2
12	11.0048	Clamp, Hose Band 9/16" OD Hose	3
13	13.0053	Filter, Fuel - In Line 5/16"	1
14	47.0328	Valve, Fuel Shut Off 5/16"	1
15	11.0038	Clamp, Hose SS 7/32 To 5/8	11
16	99.M0005	Bolt, M8 X 1.25 P X 20MM	1
17	29.BF05MP0445-1	Fitting, 5/16 Barb x 1/4 MP 45	1
18	29.BF05MP0490	Fitting, 5/16 Barb x 1/4 MP 90	1
19	13.1C010-42460	Valve, Fuel Check	1
20	00.0637	Decal, Diesel Safety	1
21	13.0270	Pump, Fuel Kub - Y	1
22	64.1687	Mount, Fuel Filter	1
23	11.0071	Clamp, Cushioned Metal 3/4" 2-Tube	1
24	47.0326-1	Tank, Asm 4500 Diesel (Serial # 01001-05559)	1
24	47.0505-1	Tank, Asm 4520 Diesel (Serial # 05560-)	1
25	64.1692	Bracket, Throttle Cable	1
26	13.0051	Filter, Fuel Assembly (Racor)	1
27	99.E0049	Nut, Washer #10-32 (Star Nut)	1
28	27.F03-103IN	Hose, Fuel Line x 3/16" x 103" L	1
29	27.F05-69IN	Hose, Fuel Line x 5/16" x 69" L	1
30	27.F05-17IN	Hose, Fuel Line x 5/16" x 17" L	1
31	27.F03-8IN	Hose, Fuel Line x 3/16" x 8" L	1
32	27.F05-13.75IN	Hose, Fuel Line x 5/16" x 13-3/4" L	1
33	27.F05-26IN	Hose, Fuel Line x 5/16" x 26" L	1
34	27.F05-2.25IN	Hose, Fuel Line x 5/16" x 2-1/4" L	1
35	30.0411	Velcro, Cable Tie	2
50	05.0133	Grommet, Tank Fitting	2
51	29.0095	Fitting, Tank 3/16 Return	1
52	29.0097	Fitting, Tank 5/16 Withdraw	1
53	05.0134	Grommet, Fuel Tank Sender	1
54	47.0414	Cap, Diesel 3-1/2" Vented	1
55	35.0120	Sending Unit, Fuel	1
65	13.0220	Filter, Fuel Element	1
66	13.0051-1	Bowl, Filter W/Drain & Plug	1

FRAMES / SHEET METAL

ILLUSTRATED DRAWING Lower Rear Frame (Serial # 01001-05664)

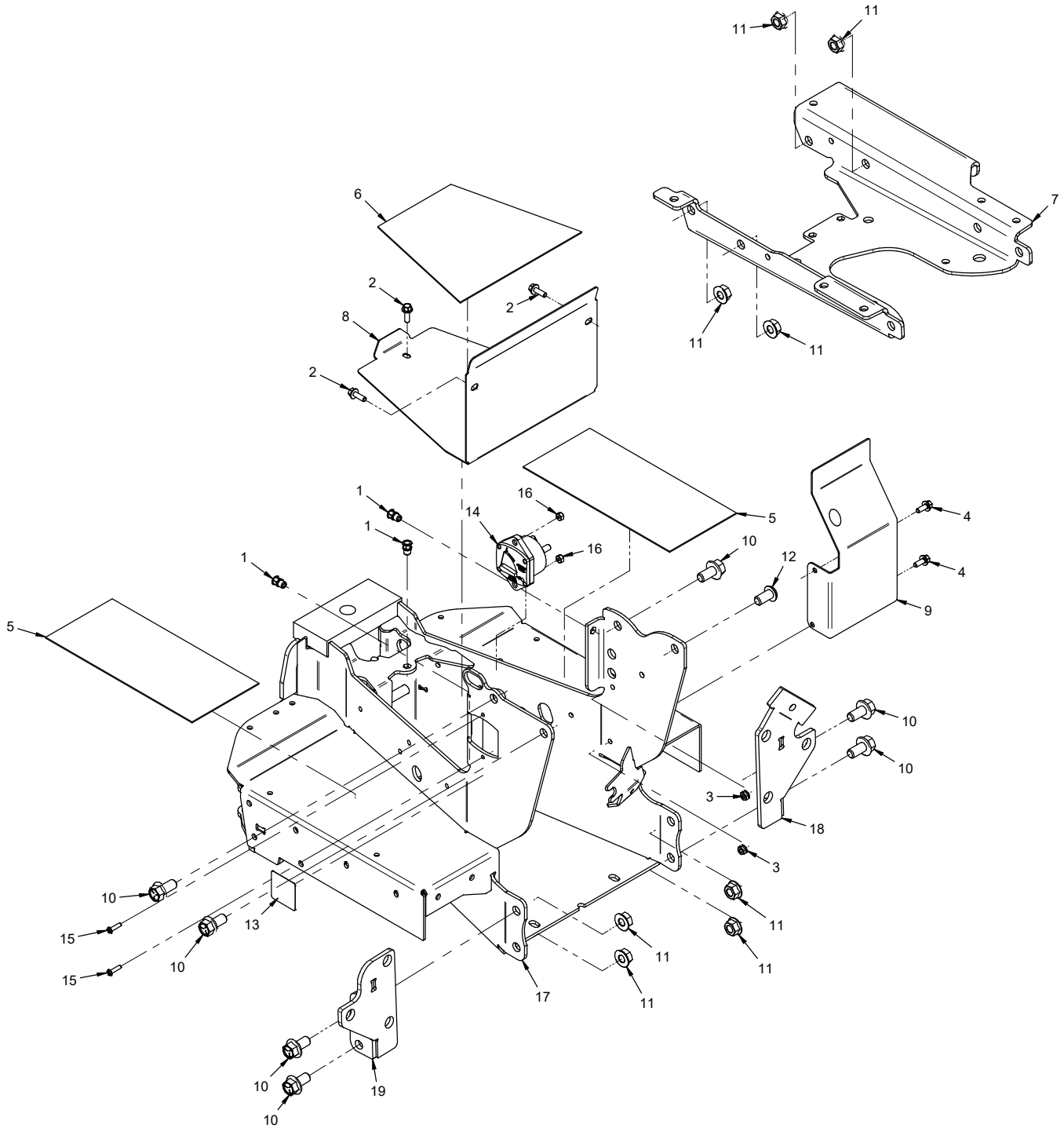

FRAMES / SHEET METAL

Lower Rear Frame (Serial # 01001-05664)

REF.	PART NO.	DESCRIPTION	QTY.
1	99.E0105	Nut, Insert 1/4-20 Hex	3
2	99.SF0406-1	Bolt, SMF 1/4-20 X 3/4	3
3	99.SF04	Nut, SRF 1/4-20 USS	2
4	99.SF0405-1	Bolt, SMF 1/4-20 X 5/8	2
5	44.0331	Flex Tread, Foot Platform KN	2
6	44.0220	Flex Tread, Tunnel Cover	1
7	KN-1027	Frame, Rear Upper	1
8	KN-1021	Cover, Rear Lower Frame	1
9	KN-1253	Panel, Foot Platform Right	1
10	99.SF0808-1	Bolt, SMF 1/2-13 x 1	7
11	99.SF08	Nut, SRF 1/2-13 USS	8
12	99.0808	Bolt, 1/2-13 x 1 BSCS	1
13	00.0315	Decal, Battery Disconnect	1
14	30.0338	Breaker, Circuit 150 Amp	1
15	99.K0047	Machine Screw, #10-32 X 3/4	2
16	99.A1032N	Locknut, Nylon 10-32 Stainless	2
17	KN-6011	Frame, Rear Lower	1
18	KN-6025	Bracket, Transaxle Mount Right	1
19	64.1594	Bracket, Transaxle Mount Left	1

FRAMES / SHEET METAL

ILLUSTRATED DRAWING Lower Rear Frame (Serial # 05665-)

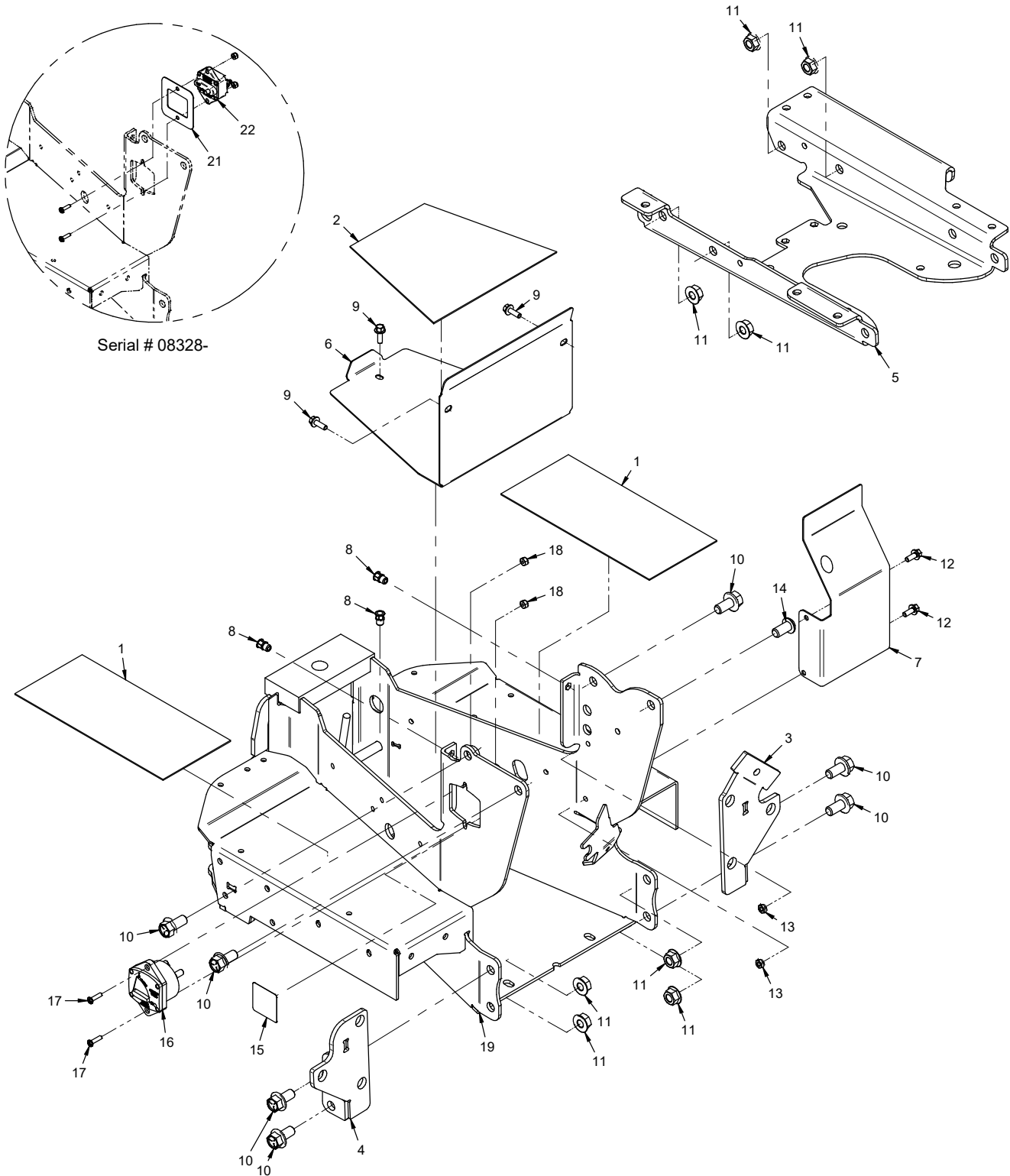

FRAMES / SHEET METAL

Lower Rear Frame (Serial # 05665-)

REF.	PART NO.	DESCRIPTION	QTY.
1	44.0331	Flex Tread, Foot Platform KN	2
2	44.0220	Flex Tread, Tunnel Cover	1
3	KN-6025	Bracket, Transaxle Mount Right	1
4	64.1594	Bracket, Transaxle Mount Left	1
5	KN-1484	Frame, Rear Upper	1
6	KN-1470	Cover, Rear Lower Frame	1
7	KN-1253	Panel, Foot Platform Right	1
8	99.E0105	Nut, Insert 1/4-20 Hex	3
9	99.SF0406-1	Bolt, SMF 1/4-20 X 3/4	3
10	99.SF0808-1	Bolt, SMF 1/2-13 x 1	7
11	99.SF08	Nut, SRF 1/2-13 USS	8
12	99.SF0405-1	Bolt, SMF 1/4-20 X 5/8	2
13	99.SF04	Nut, SRF 1/4-20 USS	2
14	99.0808	Bolt, 1/2-13 x 1 BSCS	1
15	00.0315	Decal, Battery Disconnect (Serial # 01001-08327)	1
15	00.0447	Decal, Battery Disconnect (Serial # 08328-)	1
16	30.0338	Breaker, Circuit 150 Amp (Serial # 01001-08327)	1
17	99.K0047	Machine Screw, #10-32 X 3/4 (Serial # 01001-08327)	2
17	99.0408-1	Bolt, SMF 1/4-20 x 1 (Serial # 08328-)	2
18	99.A1032N	Locknut, Nylon 10-32 Stainless (Serial # 01001-08327)	2
18	99.A04N	Locknut, Nylon 1/4-20 (Serial # 08328-)	2
19	KN-6070	Frame, Rear Lower	2
21	KN-1515	Plate, Circuit Breaker Filler (Serial # 08328-)	1
22	30.0501	Breaker, Circuit 150A (Serial # 08328-)	1

FRAMES / SHEET METAL

ILLUSTRATED DRAWING Seat Box & Upper Rear Frame (Serial # 01001-05664)

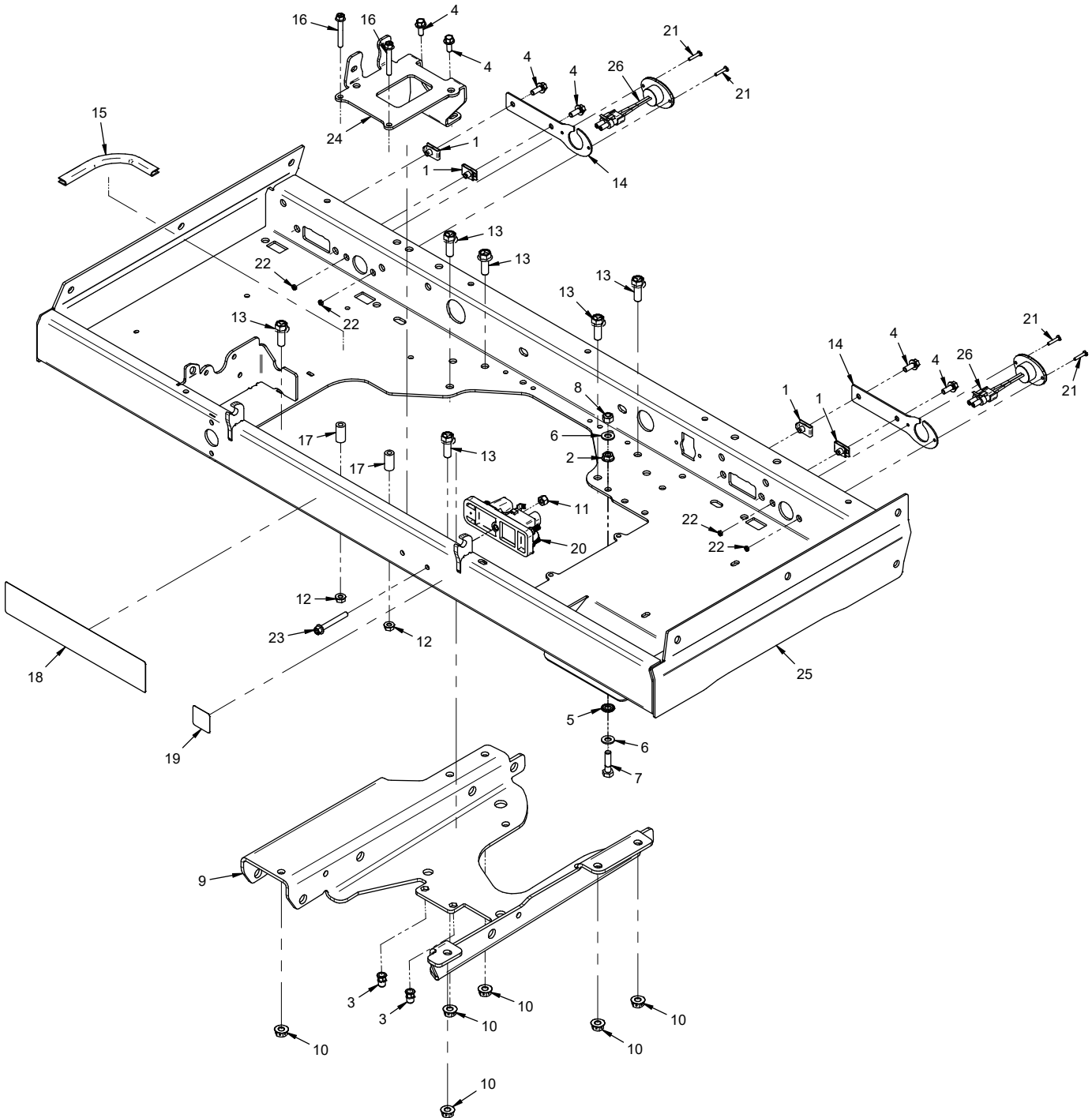

FRAMES / SHEET METAL

Seat Box & Upper Rear Frame (Serial # 01001-05664)

REF.	PART NO.	DESCRIPTION	QTY.
1	99.E0046	Nut, "U" 1/4-20 Extruded	4
2	99.SF05	Nut, SRF 5/16-18 USS	1
3	99.E0105	Nut, Insert 1/4-20 Hex	2
4	99.SF0405-1	Bolt, SMF 1/4-20 X 5/8	6
5	99.G0003	Washer, Star-External 5/16	1
6	95.05	Washer, Flat 5/16 SAE	2
7	90.0510	Bolt, 5/16-18 USS x 1-1/4	1
8	99.A05N	Locknut, Nylon 5/16-18 USS	1
9	KN-1027	Frame, Rear Upper	1
10	99.E0082	Nut, Locking Flange 3/8-16	6
11	99.A04N	Locknut, Nylon 1/4-20	1
12	99.E0101	Nut, Locking Flange 1/4-20	2
13	99.SF0608-1	Bolt, SMF 3/8-16 x 1	6
14	KN-1269	.4520	2
15	06.0050-6IN	Trim, Trim Loc 1/2 x 3/16 x 6"L	1
16	99.SF0414-1	Bolt, SMF 1/4-20 x 1-3/4	2
17	64.2035	Spacer, 1/4"ID x 1/2"OD x 1" L	2
18	00.0694	Decal, Safety 4520	1
19	00.0334	Decal, Fuel On/Off	1
20	30.0339	Module, Power Relay	1
21	99.K0060	Machine Screw, #6-32 X 3/4	4
22	99.E0085	Locknut, Nylon #6-32	4
23	99.SF0416-1	BOLT, SMF 1/4-20 X 2	1
24	KN-1146	Mount, SDLA 2 Spool Valve	1
25	KN-6018	Frame, Seatbox	1
26	33.0061	Light, Marker Red Oval	2

FRAMES / SHEET METAL

ILLUSTRATED DRAWING Seat Box & Upper Rear Frame (Serial # 05665-)

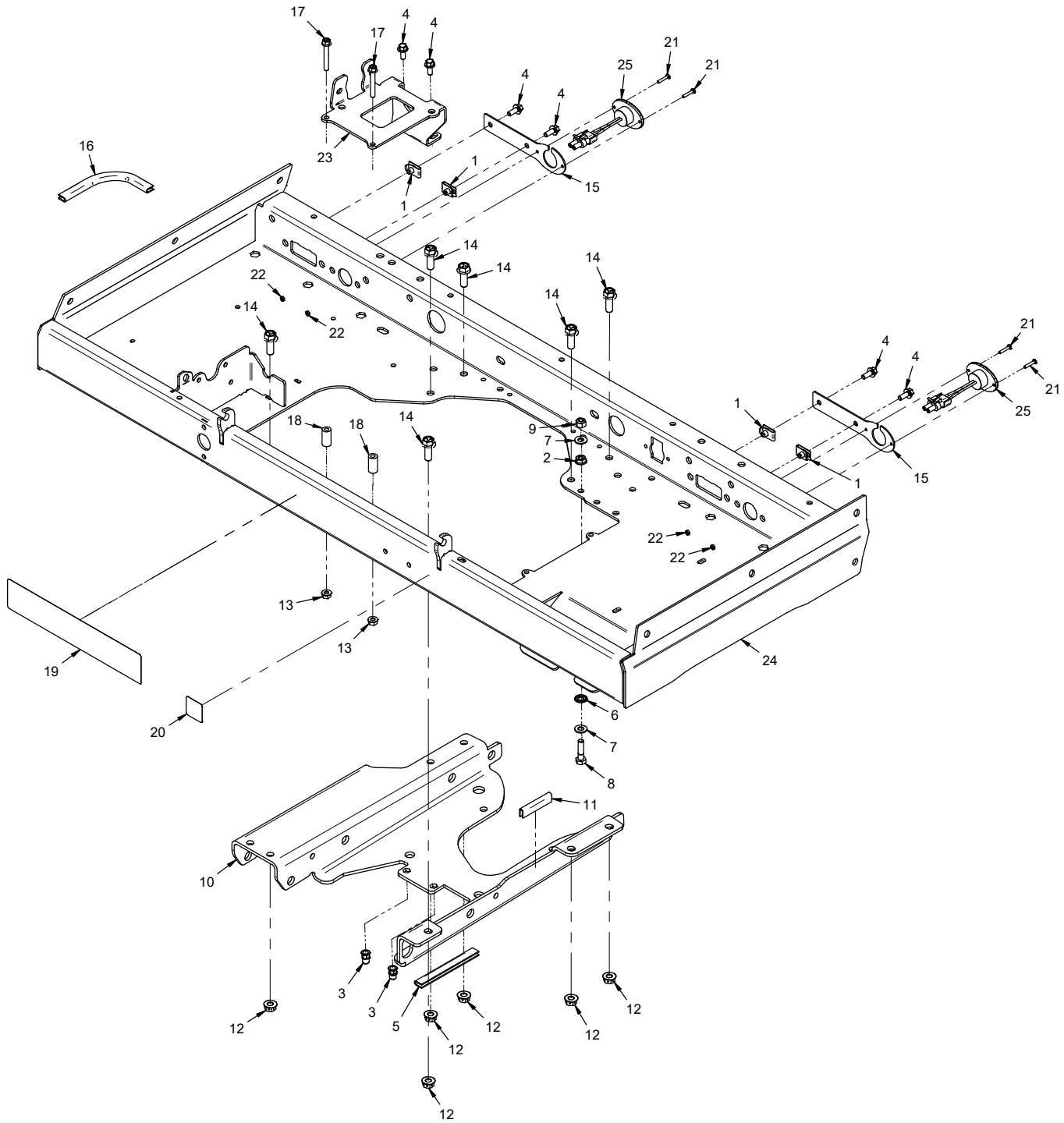

FRAMES / SHEET METAL

Seat Box & Upper Rear Frame (Serial # 05665-)

REF.	PART NO.	DESCRIPTION	QTY.
1	99.E0046	Nut, "U" 1/4-20 Extruded	4
2	99.SF05	Nut, SRF 5/16-18 USS	1
3	99.E0105	Nut, Insert 1/4-20 Hex	2
4	99.SF0405-1	Bolt, SMF 1/4-20 X 5/8	6
5	06.0050-4.5IN	Trim, Trim Loc 1/2 x 3/16 x 4-1/2"	1
6	99.G0003	Washer, Star-External 5/16	1
7	95.05	Washer, Flat 5/16 SAE	2
8	90.0510	Bolt, 5/16-18 USS x 1-1/4	1
9	99.A05N	Locknut, Nylon 5/16-18 USS	1
10	KN-1484	Frame, Rear Upper	1
11	06.0050-2.25IN	Trim, Trim Loc 1/2 x 3/16 x 2-1/4"	1
12	99.E0082	Nut, Locking Flange 3/8-16	6
13	99.E0101	Nut, Locking Flange 1/4-20	2
14	99.SF0608-1	Bolt, SMF 3/8-16 x 1	6
15	KN-1269	Cover, Seatbox Blank	2
16	06.0050-6IN	Trim, Trim Loc 1/2 x 3/16 x 6"	1
17	99.SF0414-1	Bolt, SMF 1/4-20 x 1-3/4	2
18	64.2035	Spacer, 1/4"ID x 1/2"OD x 1"L	2
19	00.0694	Decal, Safety 4520	1
20	00.0334	Decal, Fuel On/Off	1
21	99.K0060	Machine Screw, #6-32 X 3/4	4
22	99.E0085	Locknut, Nylon #6-32	4
23	KN-1146	Mount, SDLA 2 Spool Valve	1
24	KN-6078	Frame, Seatbox	1
25	33.0061	Light, Marker Red Oval	2

FRAMES / SHEET METAL

ILLUSTRATED DRAWING

Left Seat Box Panels

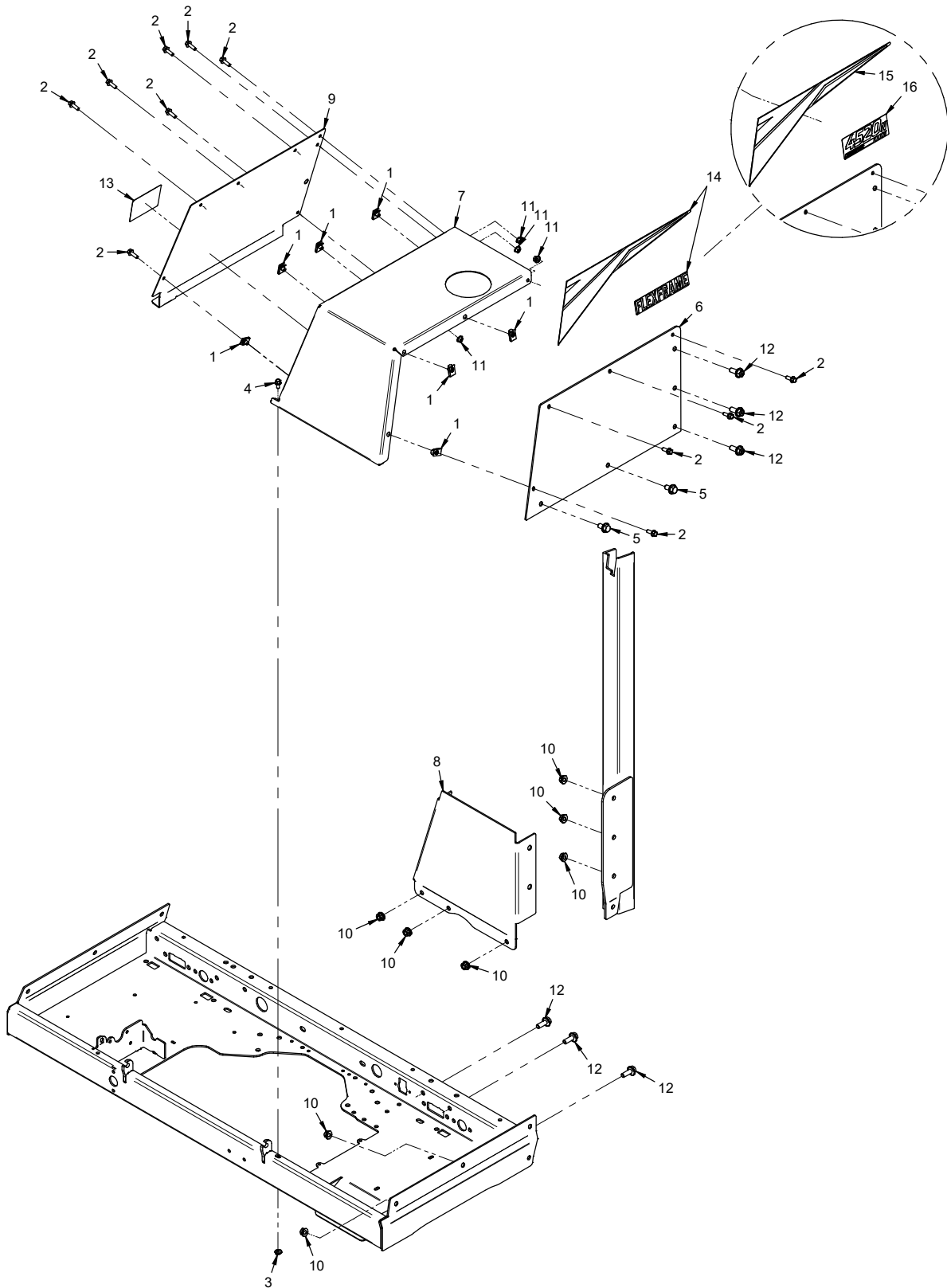

FRAMES / SHEET METAL

Left Seat Box Panels

REF.	PART NO.	DESCRIPTION	QTY.
1	99.E0046	Nut, "U" 1/4-20 Extruded	7
2	99.SF0406-1	Bolt, SMF 1/4-20 X 3/4	10
3	99.SF04	Nut, SRF 1/4-20 USS	1
4	99.SF0404-1	Bolt, SMF 1/4-20 X 1/2	2
5	99.SF0606-1	Bolt, SMF 3/8-16 USS x 3/4	2
6	60.1148	Panel, Seatbox Left	1
7	KN-1205	Cover, Fuel Tank Main	1
8	KN-1204	Panel, Seatbox Rear Left	1
9	60.1125	Cover, Fuel Tank Inner	1
10	99.E0082	Nut, Locking Flange 3/8-16	8
11	99.E0101	Nut, Locking Flange 1/4-20	4
12	99.SF0608-1	Bolt, SMF 3/8-16 x 1	6
13	00.0629	Decal, Battery Hazard	1
14	00.0666	Decal, Rear Fender Left (Serial # 01001-05658)	1
15	00.0741	Decal, Rear Fender Left (Serial # 05659-)	1
16	00.0736	Decal, 4520K (Serial # 05659-)	1
16	00.0738	Decal, 4520P (Serial # 05659-)	1
16	00.0739	Decal, 4520Y (Serial # 05659-)	1
16	00.0740	Decal, 4520Z (Serial # 05659-)	1

FRAMES / SHEET METAL

ILLUSTRATED DRAWING

Right Seat Box Panels

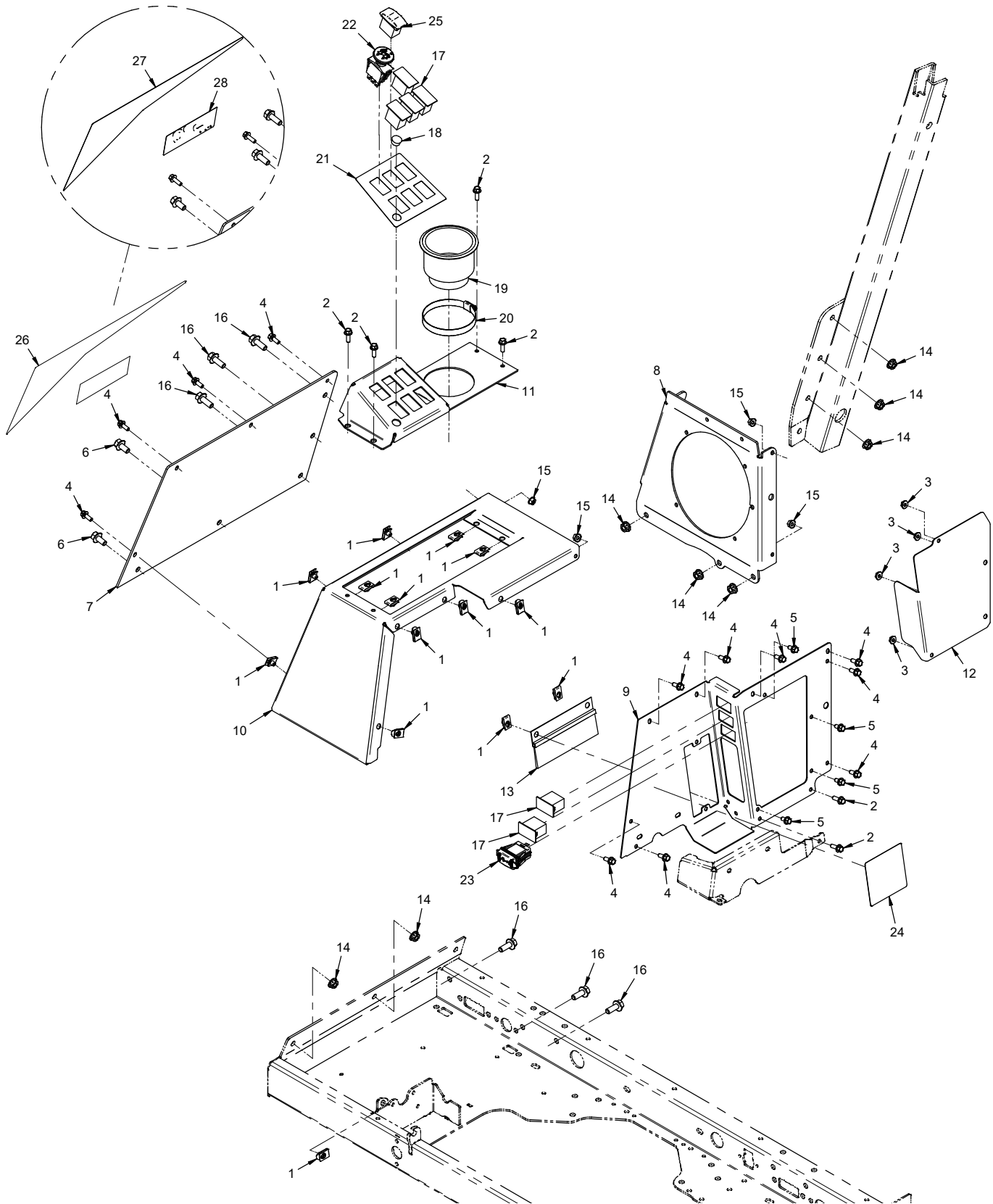

FRAMES / SHEET METAL

Right Seat Box Panels

REF.	PART NO.	DESCRIPTION	QTY.
1	99.E0046	Nut, "U" 1/4-20 Extruded	13
2	99.SF0406-1	Bolt, SMF 1/4-20 X 3/4	15
3	99.SF04	Nut, SRF 1/4-20 USS	6
4	99.SF0405-1	Bolt, SMF 1/4-20 X 5/8	1
5	99.SF0404-1	Bolt, SMF 1/4-20 X 1/2	6
6	99.SF0606-1	Bolt, SMF 3/8-16 USS x 3/4	2
7	60.1148	Panel, Seatbox Left	1
8	KN-1201	Panel, Seatbox Rear Right	1
9	KN-1198	Panel, Hyd Cooler Inner	1
10	KN-1238	Cover, Hyd Cooler Top Front	1
11	KN-1227	Panel, Control	1
12	64.1596	Screen, Hyd. Oil Cooler	1
13	79.0093	Brush, Side Panel w/Holder	1
14	99.E0082	Nut, Locking Flange 3/8-16	8
15	99.E0101	Nut, Locking Flange 1/4-20	2
16	99.SF0608-1	Bolt, SMF 3/8-16 x 1	6
17	05.0131	Plug, Switch Otto K5	6
18	05.0139	Plug, 5/8" Hole, Blk Plastic	1
19	47.0185	Holder, Cup 3.586 OD x 3-1/4 DP	1
20	11.0077	Clamp, Hose 3-1/16 To 4"	1
21	00.0687	Decal, Control Panel	1
22	31.0043	Switch, PTO - Push/Pull	1
23	30.0542	Receptacle, USB Dual	1
24	00.0316	Decal, SDLA	1
25	31.0053	Switch, Rocker On/Off	1
26	00.0667	Decal, Rear Fender Right (Serial # 01001-05658)	1
27	00.0742	Decal, Rear Fender Right (Serial # 05659-)	1
28	00.0736	Decal, 4520K (Serial # 05659-)	1
28	00.0738	Decal, 4520P (Serial # 05659-)	1
28	00.0739	Decal, 4520Y (Serial # 05659-)	1
28	00.0740	Decal, 4520Z (Serial # 05659-)	1

FRAMES / SHEET METAL

ILLUSTRATED DRAWING

Roll Bar

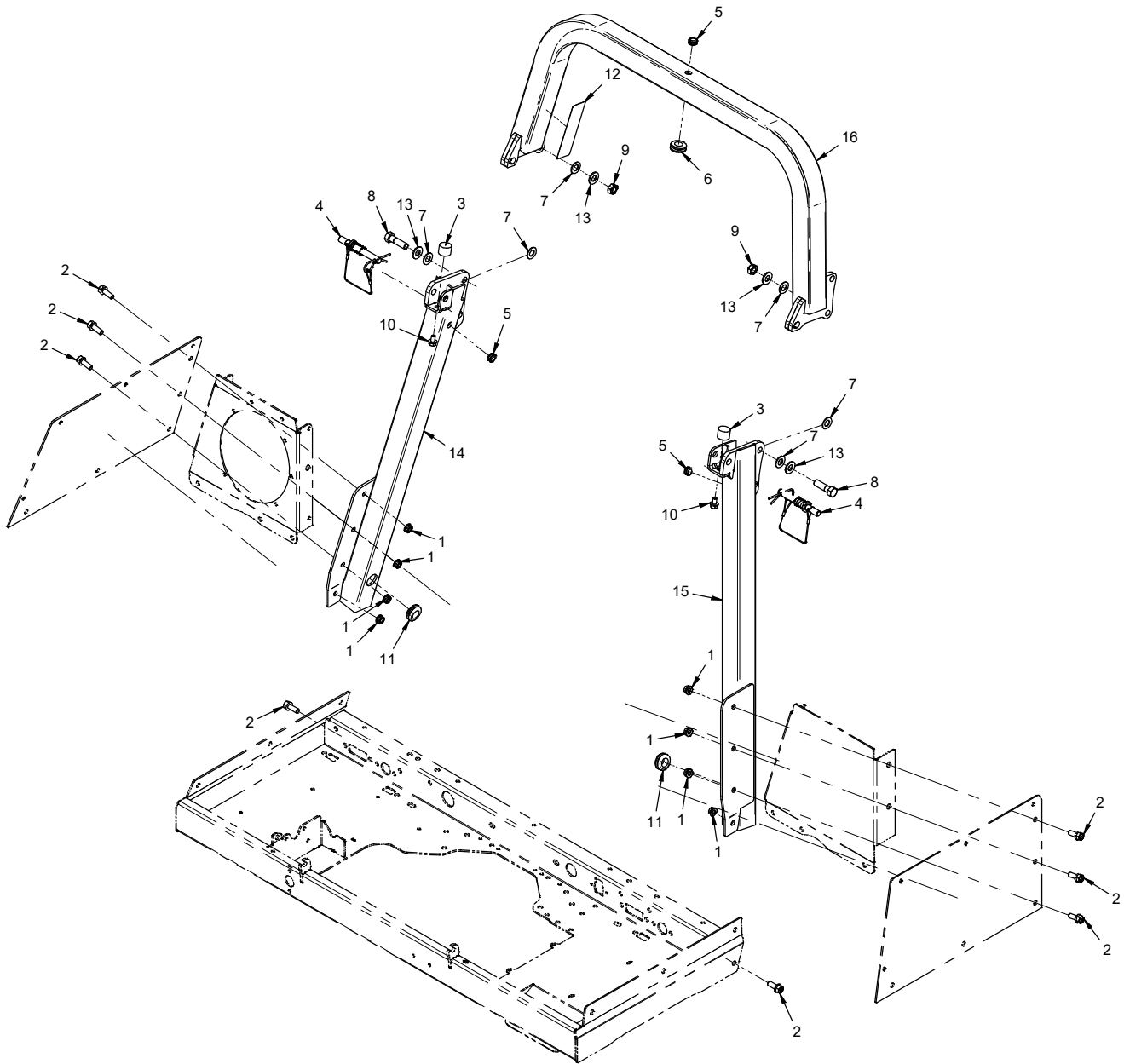

FRAMES / SHEET METAL

Roll Bar

REF.	PART NO.	DESCRIPTION	QTY.
1	99.E0082	Nut, Locking Flange 3/8-16	8
2	99.SF0608-1	Bolt, SMF 3/8-16 x 1	8
3	05.0110	Bumper, Neoprene 1" Dia	2
4	03.0037	Pin, Knurled w/Spring & Lanyard	2
5	05.0138	Grommet, 7/16ID, 11/16OD, 3/8Thk.	3
6	05.0196	Grommet, 11/16" ID, 1 5/16" OD, 1/2" Thk	1
7	05.0145	WASHER, .55ID x 1.03OD x .062T	6
8	90.0814	Bolt, 1/2-13 USS x 1-3/4	2
9	99.A08	Locknut, Stover 1/2-13 USS	2
10	99.SF0504-1	Bolt, SMF 5/16-18 USS x 1/2	2
11	05.0045	Grommet, 3/4Id, 1 3/8Od, 1/2Thk.	2
12	00.0644	Decal, ROPS 4500/4520	1
13	95.08	Washer, Flat 1/2 SAE	4
14	62.1510	Roll Bar, Fold Down Right	1
15	62.1511	Roll Bar, Fold Down Left	1
16	62.1509	Roll Bar, Fold Down Top	1

FRAMES / SHEET METAL

ILLUSTRATED DRAWING

Standard Rear Hitch

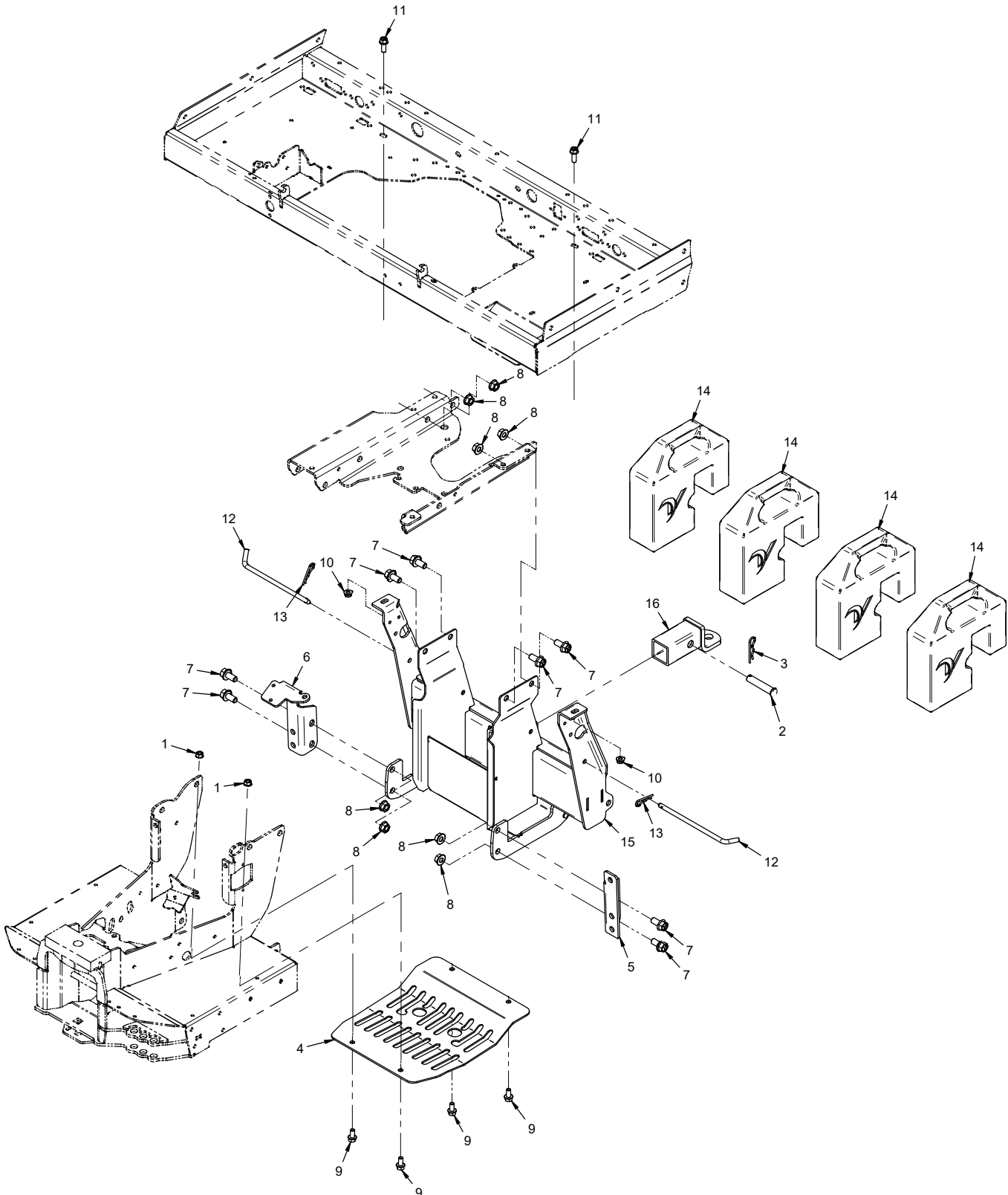

FRAMES / SHEET METAL

Standard Rear Hitch

REF.	PART NO.	DESCRIPTION	QTY.
1	99.SF06	Nut, SRF 3/8-16 USS	4
2	03.1024	Clevis Pin, 5/8 X 3 OAL ZP	1
3	02.HP0420	Hairpin, 1/8 x 2 9/16 ZP	1
4	64.1867	Plate, Rear Axle Skid No 3PT	1
5	64.1865	Bracket, Rear Hitch Mt Left	1
6	KN-1032	Bracket, Rear Hitch Mt Right	1
7	99.SF0808-1	Bolt, SMF 1/2-13 x 1	8
8	99.SF08	Nut, SRF 1/2-13 USS	8
9	99.SF0606-1	Bolt, SMF 3/8-16 USS x 3/4	4
10	99.E0082	Nut, Locking Flange 3/8-16	2
11	99.SF0608-1	Bolt, SMF 3/8-16 x 1	2
12	64.0761	Pin, Weight Secure 7.3" Usable	2
13	02.HP0416	Hairpin, 1/8 X 2 ZP	2
14	47.0115-1	Weight, Suitcase - 42 LBS	4
15	62.1363	Frame, Rear Weight Bar/Hitch	1
16	62.0968	Hitch, Rear	1

FRAMES / SHEET METAL

ILLUSTRATED DRAWING

Rear Fenders & Battery Compartment (Serial # 01001-05664)

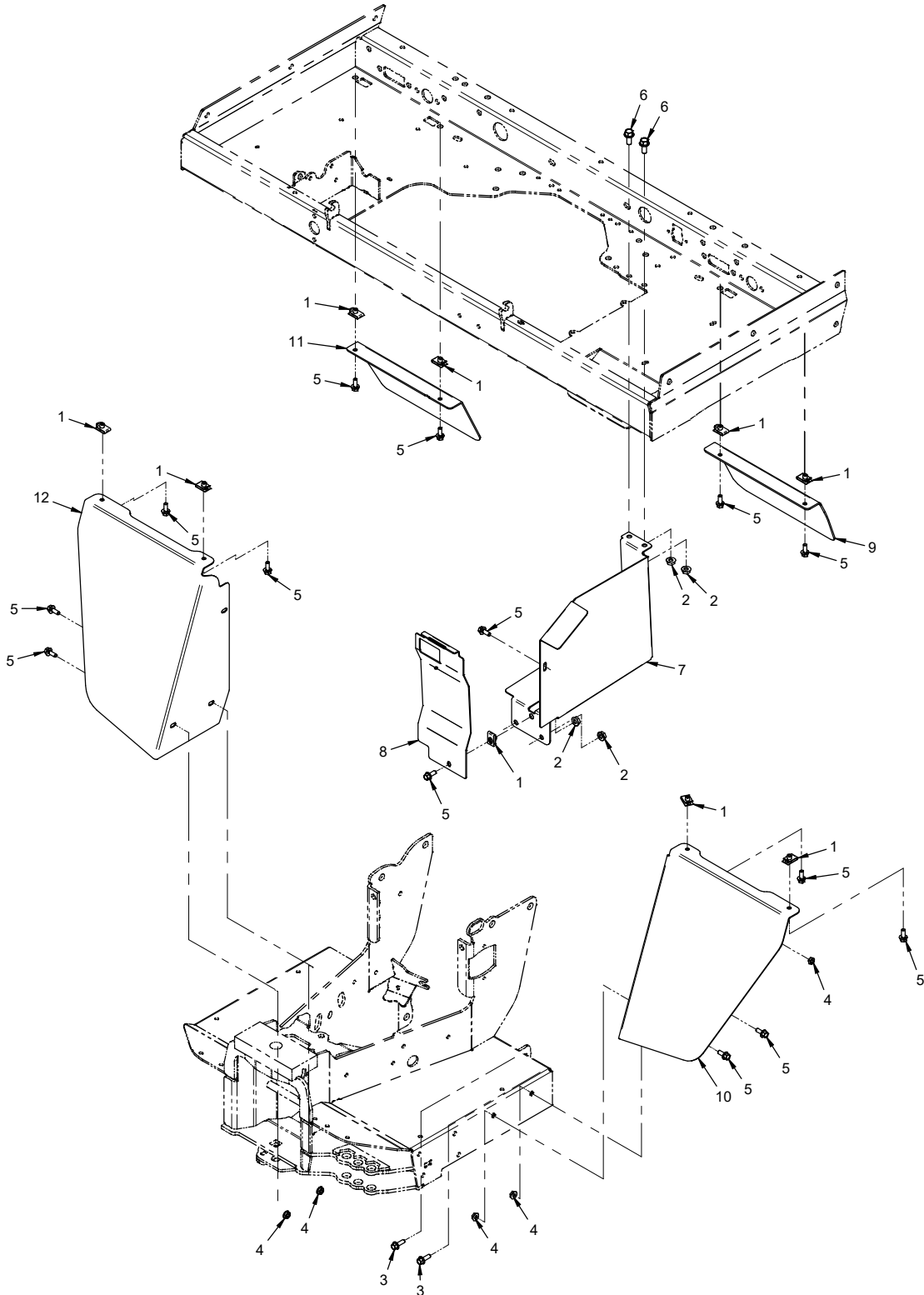

FRAMES / SHEET METAL

Rear Fenders & Battery Compartment (Serial # 01001-05664)

REF.	PART NO.	DESCRIPTION	QTY.
1	99.E0046	Nut, "U" 1/4-20 Extruded	9
2	99.SF05	Nut, SRF 5/16-18 USS	4
3	99.SF0406-1	Bolt, SMF 1/4-20 X 3/4.	2
4	99.SF04	Nut, SRF 1/4-20 USS	5
5	99.SF0405-1	Bolt, SMF 1/4-20 X 5/8.	14
6	99.SF0506-1	Bolt, SMF 5/16-18 USS X 3/4.	2
7	60.1116	Panel, Battery Compartment.	1
8	60.1117	Panel, Foot Platform Left	1
9	60.1127	Fender, Rear Flap Left.	1
10	60.1130	Fender, Rear Left	1
11	60.1146	Fender, Rear Flap Right	1
12	60.1131	Fender, Rear Right.	1

FRAMES / SHEET METAL

ILLUSTRATED DRAWING Rear Fenders & Battery Compartment (Serial # 05665-)

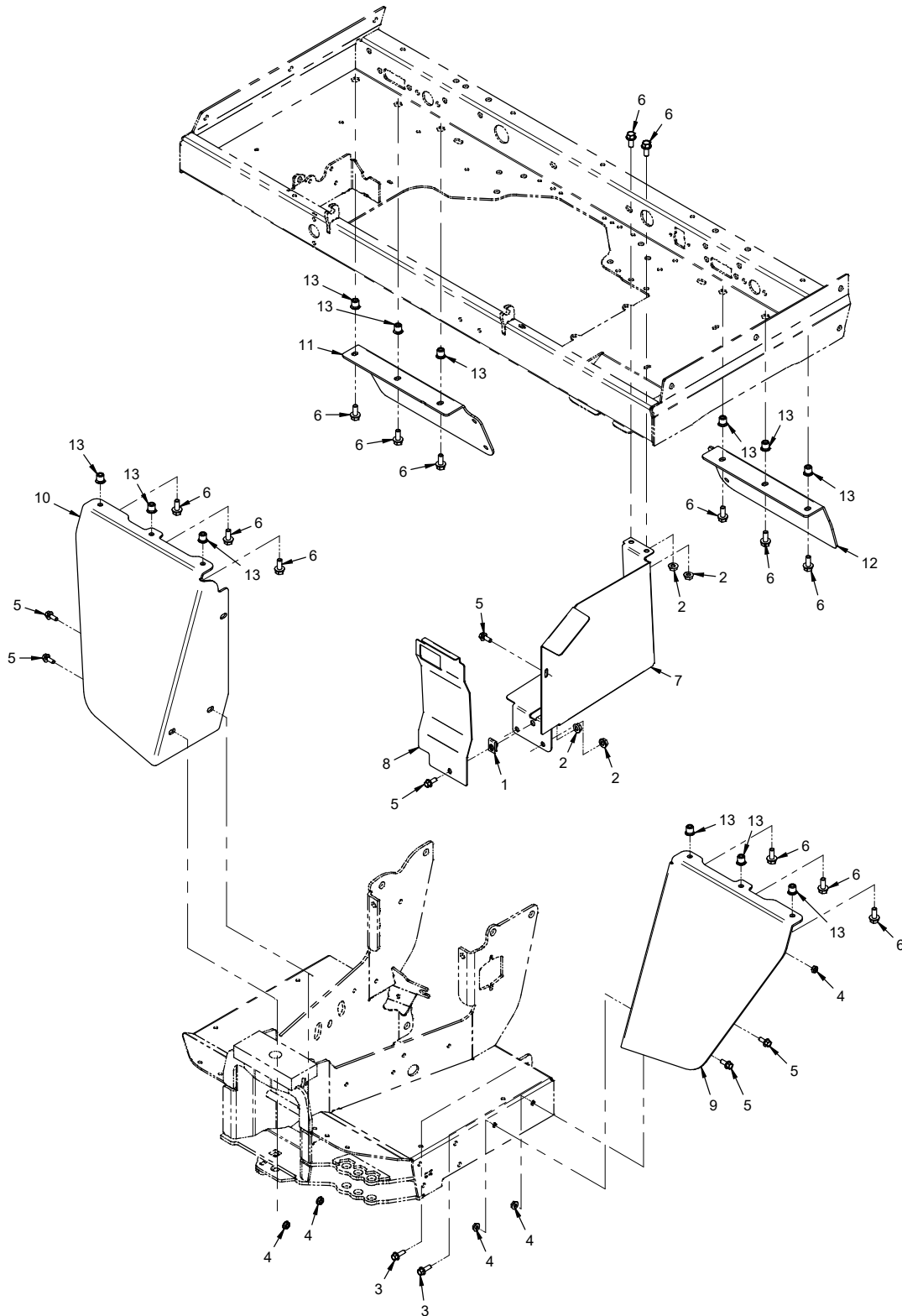

FRAMES / SHEET METAL

Rear Fenders & Battery Compartment (Serial # 05665-)

REF.	PART NO.	DESCRIPTION	QTY.
1	99.E0046	Nut, "U" 1/4-20 Extruded	1
2	99.SF05	Nut, SRF 5/16-18 USS	4
3	99.SF0406-1	Bolt, SMF 1/4-20 X 3/4.	2
4	99.SF04	Nut, SRF 1/4-20 USS	5
5	99.SF0405-1	Bolt, SMF 1/4-20 X 5/8.	6
6	99.SF0506-1	Bolt, SMF 5/16-18 USS x 3/4.	14
7	60.1116	Panel, Battery Compartment.	1
8	60.1117	Panel, Foot Platform Left	1
9	KN-1480	Fender, Rear Left	1
10	KN-1481	Fender, Rear Right.	1
11	KN-1483	Fender, Rear Flap Right	1
12	KN-1482	Fender, Rear Flap Left.	1
13	99.E0155	Nut, Insert 5/16-18 Hex	12

FRAMES / SHEET METAL

ILLUSTRATED DRAWING

Standard Seat Assembly

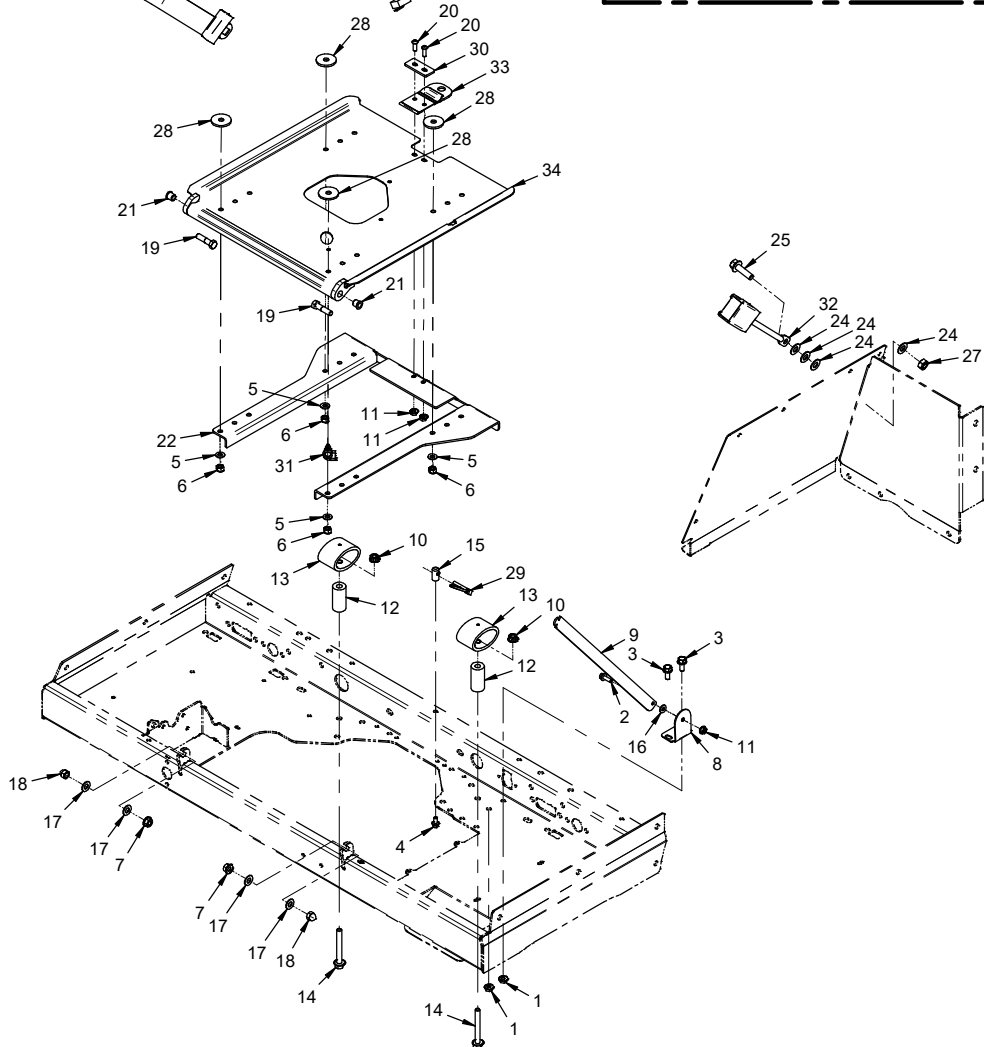
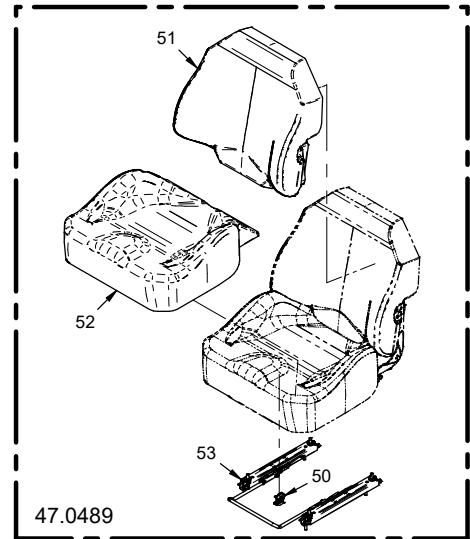
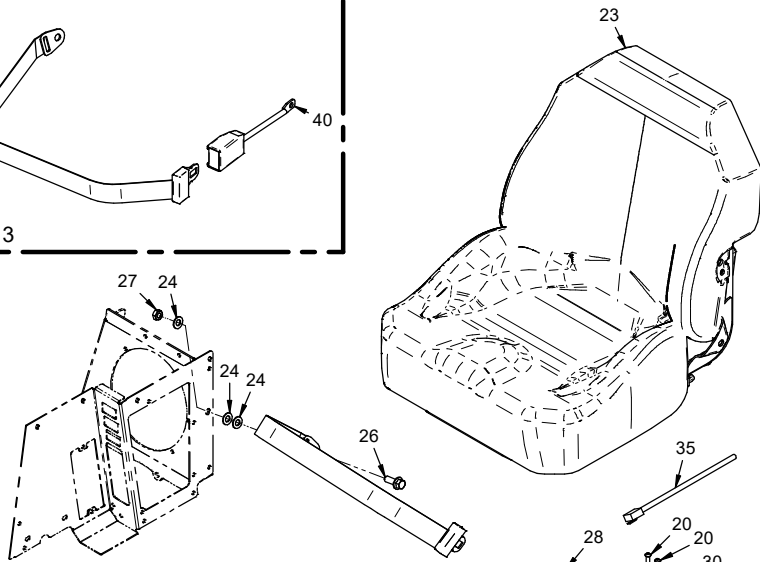
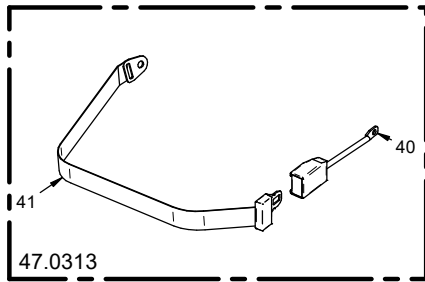

FRAMES / SHEET METAL

Standard Seat Assembly

REF.	PART NO.	DESCRIPTION	QTY.
1	99.SF05	Nut, SRF 5/16-18 USS	2
2	99.SF0406-1	Bolt, SMF 1/4-20 X 3/4	1
3	99.SF0506-1	Bolt, SMF 5/16-18 USS x 3/4	2
4	99.SF0404-1	Bolt, SMF 1/4-20 X 1/2	1
5	95.05	Washer, Flat 5/16 SAE	4
6	99.A05N	Locknut, Nylon 5/16-18 USS	4
7	99.SF06	Nut, SRF 3/8-16 USS	2
8	64.1598	Bracket, Seat Prop	1
9	64.1599	Plate, Seat Prop	1
10	99.E0082	Nut, Locking Flange 3/8-16	2
11	99.E0101	Nut, Locking Flange 1/4-20	3
12	64.1681	Tube, Seat Bumper	2
13	05.0137	Bumper, Elastomer 3.4"	2
14	99.SF0624-1	Bolt, SMF 3/8-16 X 3	2
15	03.0019	Pin, Seat Latch	1
16	95.04	Washer, Flat 1/4 SAE	1
17	95.06	Washer, Flat 3/8 SAE	4
18	99.E0100	Nut, Acorn 3/8-16	2
19	90.0612	Bolt, 3/8-16 USS x 1-1/2	2
20	99.0406	Bolt, 1/4-20 x 3/4 BSCS	2
21	85.B0068	Bushing, 3/8 X 1/2 OD X 1/2 LG	2
22	KN-1147	Plate, Seat Support	1
23	47.0489	Seat, Deluxe High Back	1
24	95.07	Washer, Flat 7/16 SAE	7
25	99.SF0712-1	Bolt, SMF 7/16-14 X 1-1/2	1
26	99.SF0710-1	Bolt, SMF 7/16-14 X 1-1/4	1
27	99.A07	Locknut, Stover 7/16-14 USS	2
28	99.B0076	Washer, .130T x .395ID x 1.5OD	4
29	03.0021	Pin, Linch (3/16)	1
30	64.1723	Clamp, Seat Latch Strap	1
31	30.0135	Clamp, Loom 3/8 Rosebud Mount	1
32	47.0313	Seat Belt, Lap w/Buckle	1
33	47.0335	Strap, Seat Latch	1
34	KN-6036	Mount, Seat	1
35	32.0224	Harness, Wire 4520 Seat	1
40	47.0313-2	Seat Belt, Buckle	1
41	47.0313-1	Seat Belt, Lap Belt	1
50	31.0079	Switch, Seat Delta N/O	1
51	47.0511	Cover, Back V Logo	1
52	47.0512	Cover, Seat Cushion	1
53	47.0513	Rail Set, Slide Adjustment	1

FRAMES / SHEET METAL

ILLUSTRATED DRAWING

Front Frame, Frame Connector Bracket, Hose Retainer

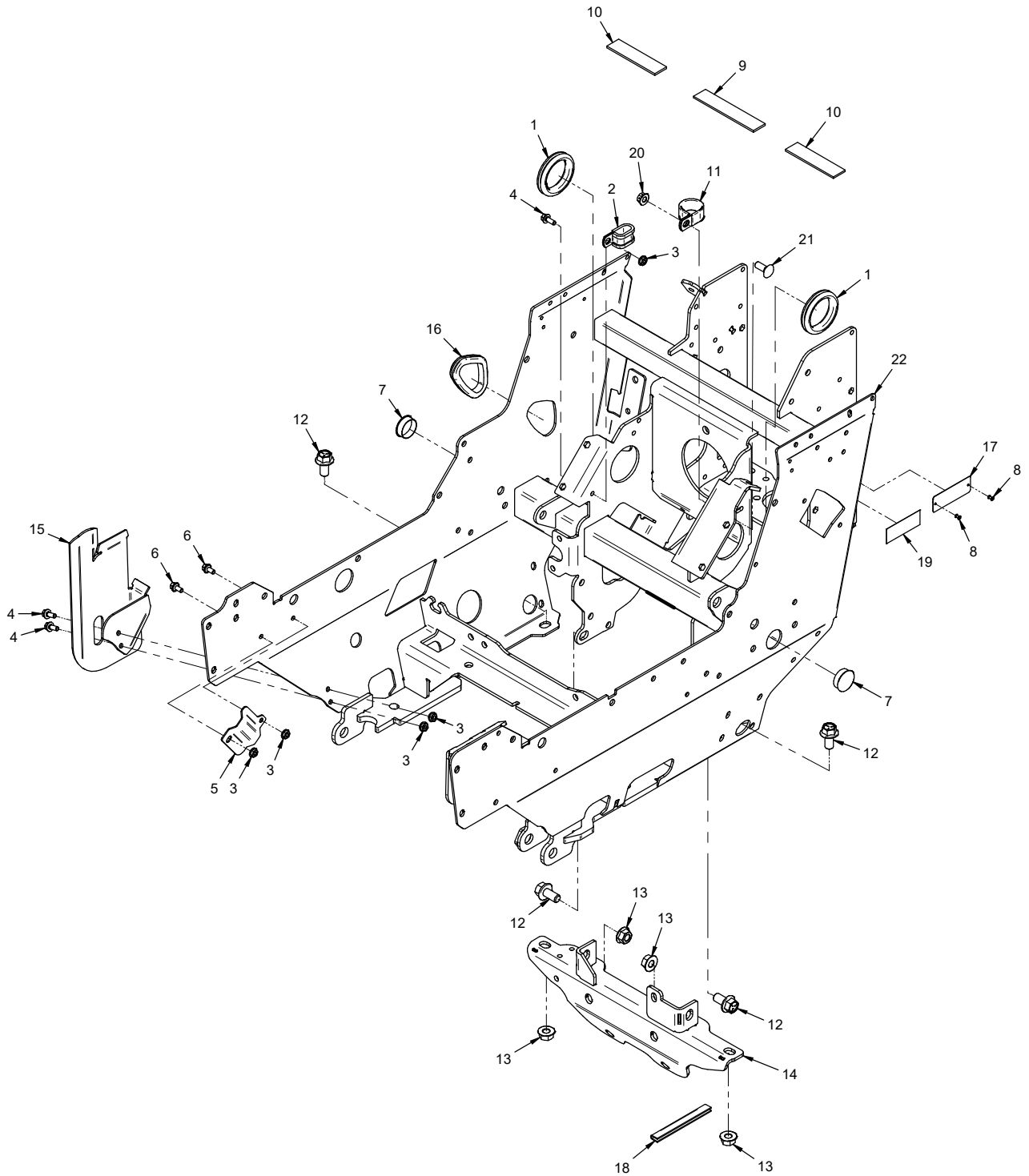

FRAMES / SHEET METAL

Front Frame, Frame Connector Bracket, Hose Retainer

REF.	PART NO.	DESCRIPTION	QTY.
1	05.0073	Grommet, 2 ID, 2-3/4 OD 9/16 T	2
2	11.0046	Clamp, Cushioned 1/2" 2-Tube	1
3	99.SF04	Nut, SRF 1/4-20 USS	5
4	99.SF0405-1	Bolt, SMF 1/4-20 X 5/8	3
5	64.1729	Retainer, Wire Loom	1
6	99.SF0404-1	Bolt, SMF 1/4-20 X 1/2	2
7	05.0091	Plug, 1-1/4" Hole, Blk Plastic	2
8	04.0029	Rivet, Pop 1/8" X 1/4" SS	2
9	06.0065-5IN	Velcro, Loop 1" Black x 5"	1
10	06.0065-4IN	Velcro, Loop 1" Black x 4"	2
11	44.0418	Clamp, 1-1/4" Loop Vinyl Cushion	1
12	99.SF0808-1	Bolt, SMF 1/2-13 x 1	4
13	99.SF08	Nut, SRF 1/2-13 USS	4
14	KN-6013	Bracket, Connector Frame MT	1
15	KN-6038	Bracket, Hose Retainer	1
16	05.0148	Grommet, 2-1/2ID, 3-1/8OD, 3/8T	1
17	N/A	Plate, Ventrac Serial Number	1
18	06.0050-4.5IN	Trim, Trim Loc 1/2 x 3/16 x 4-1/2"	1
19	00.0100	Decal, Built in the USA	1
20	99.E0082	Nut, Locking Flange 3/8-16	1
21	97.0608	Bolt, Carriage 3/8-16 x 1	1
22	KN-6010	Frame, Main Front	2

FRAMES / SHEET METAL

ILLUSTRATED DRAWING Front Fenders & Foot Pegs

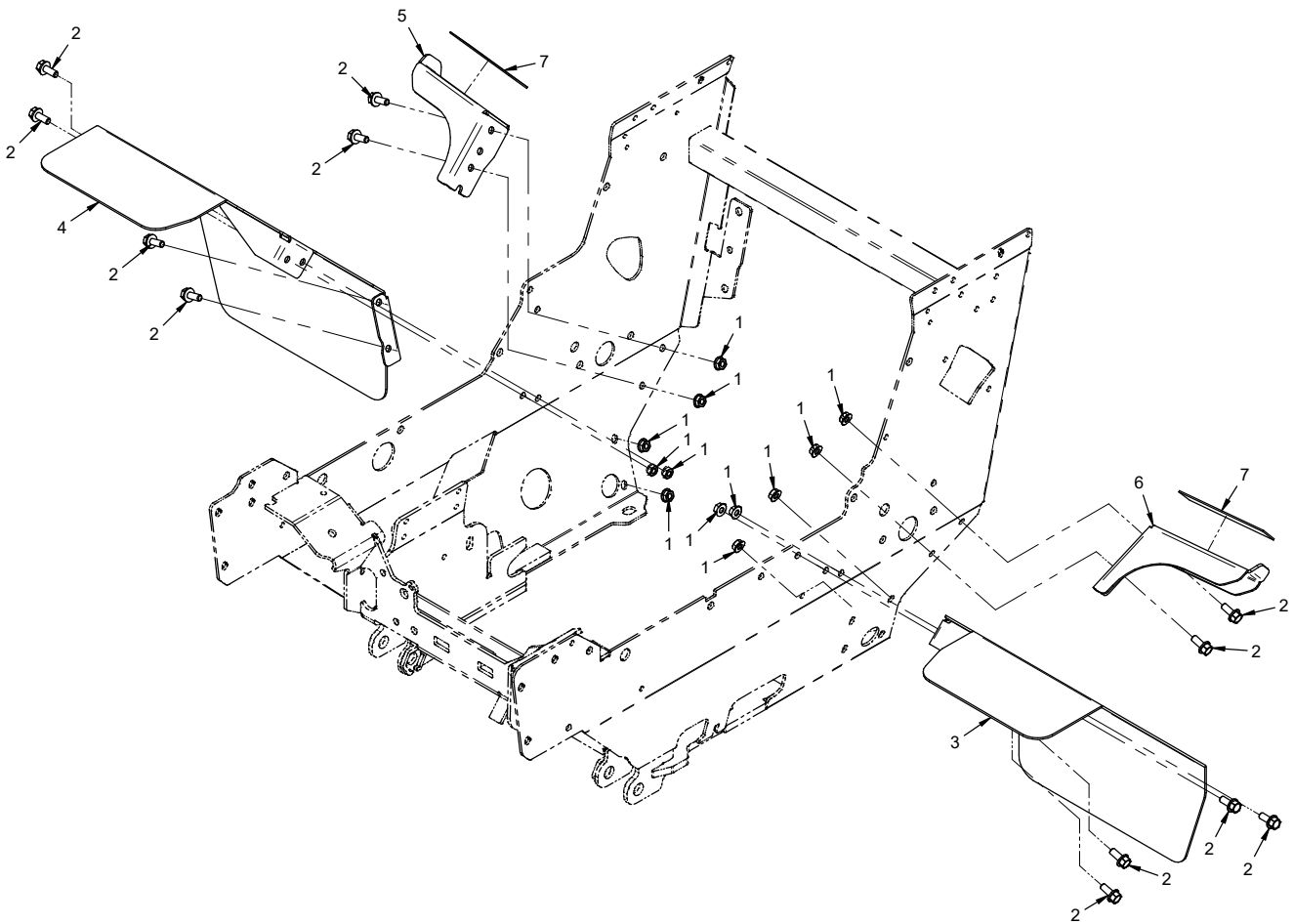

FRAMES / SHEET METAL

Front Fenders & Foot Pegs

REF.	PART NO.	DESCRIPTION	QTY.
1	99.SF05	Nut, SRF 5/16-18 USS	12
2	99.SF0506-1	Bolt, SMF 5/16-18 USS X 3/4.	12
3	60.1133	Fender, Front Left	1
4	60.1134	Fender, Front Right	1
5	64.1707	Foot Peg, Right	1
6	64.1708	Foot Peg, Left	1
7	44.0330	Flex Tread, Foot Peg KN	2

FRAMES / SHEET METAL

ILLUSTRATED DRAWING

Center Pivot & Connector Link

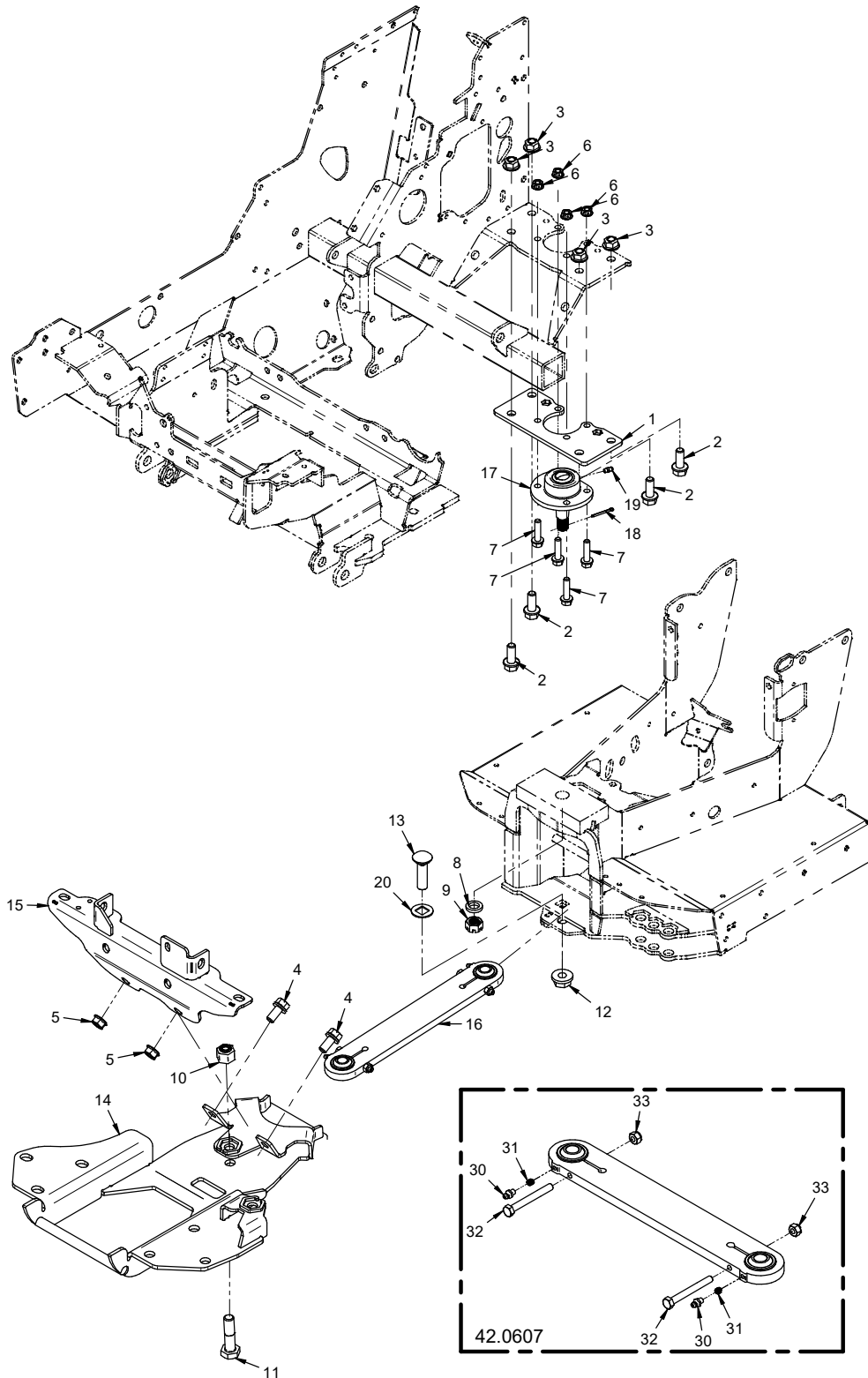

FRAMES / SHEET METAL

Center Pivot & Connector Link

REF.	PART NO.	DESCRIPTION	QTY.
1	KN-1185	.Mount, Main Pivot Flange	1
2	99.SF0810-1	.Bolt, SMF 1/2-13 x 1-1/4	4
3	99.E0103	.Nut, Locking Flange 1/2-13	4
4	99.SF0808-1	.Bolt, SMF 1/2-13 x 1	2
5	99.SF08	.Nut, SRF 1/2-13 USS	2
6	99.E0082	.Nut, Locking Flange 3/8-16	4
7	99.SF0612-1	.BOLT, SMF 3/8-16 X 1-1/2	4
8	99.B0061	.Washer, 3/16 X 21/32 X 1 1/32	1
9	99.E0057	.NUT, CASTLE 5/8-18 SAE	1
10	99.E0095	.Locknut, 5/8-11 Heavy Nylon	1
11	99.K0112	.Bolt, 5/8-11 X 2-1/2 Grd A325	1
12	99.E0094	.Locknut, 5/8-11 Flanged Stover	1
13	97.1018	.Bolt, Carriage 5/8-11 x 2-1/4 GR5	1
14	62.1371	.Revised KN-220, KN-222	1
15	KN-6013	.Bracket, Connector Frame MT	1
16	42.0607	.Link, Front/Rear Connector	1
17	43.1007	.Ball Joint, Main Articulating	1
18	02.CP0410	.Cotter Pin, 1/8 X 1-1/4	1
19	29.GF0001	.Grease Ftg, 1/4 SAE ST	1
20	64.1724	.Spacer, Connector Link Bolt	1
30	29.GF0020	.Grease Fitting, M6 x 1.0	2
31	85.SS32	.Set Screw, M6-1.0 Hollow	2
32	99.M0075	.Bolt, M8 X 1.25 X 70mm	2
33	99.M0068	.Nut, M8 x 1.25 Nylon Lock	2

FRAMES / SHEET METAL

Front Hitch

REF.	PART NO.	DESCRIPTION	QTY.
1	64.1617	.Lock, Front Hitch Lever	1
2	06.0044	.Cap, Plastic 1/8 x 1/2 x 7/8	1
3	99.SF0508-1	.Bolt, SMF 5/16-18 x 1	1
4	00.0317	.Decal, Front Hitch Lock	1
5	99.E0102	.Nut, Locking Flange 5/16-18	1
6	05.0055	.Washer, Nylon .34 x .74 x .062	3
7	99.SF06	.Nut, SRF 3/8-16 USS	3
8	41.0039	.Spring, Comp. 9/16 OD X 5/8	1
9	95.06	.Washer, Flat 3/8 SAE	2
10	40.0376	.Lever, Front Hitch Latch	1
11	99.SF0614-1	.Bolt, SMF 3/8-16 X 1-3/4	1
12	42.0558	.Link, Front Hitch Latch	1
13	06.0051	.Cap, 3/16 x 15/16 x 1-3/4 FE	1
14	90.0610	.Bolt, 3/8-16 USS x 1-1/4	1
15	02.CP0406	.Cotter Pin, 1/8 X 3/4, Zinc	1
16	99.E0100	.Nut, Acorn 3/8-16	1
17	64.1609	.Bushing, Front Hitch Pivot	2
18	29.GF0002	.Grease Ftg, 1/4 SAE 90	2
19	99.K0121	.Bolt, 5/8-11 X 3-1/4 Grd A325	2
20	99.E0095	.Locknut, 5/8-11 Heavy Nylon	2
21	KN-6040	.Frame, Front Hitch	1

FRAMES / SHEET METAL

ILLUSTRATED DRAWING Grill & Headlights (Serial # 01001-05664)

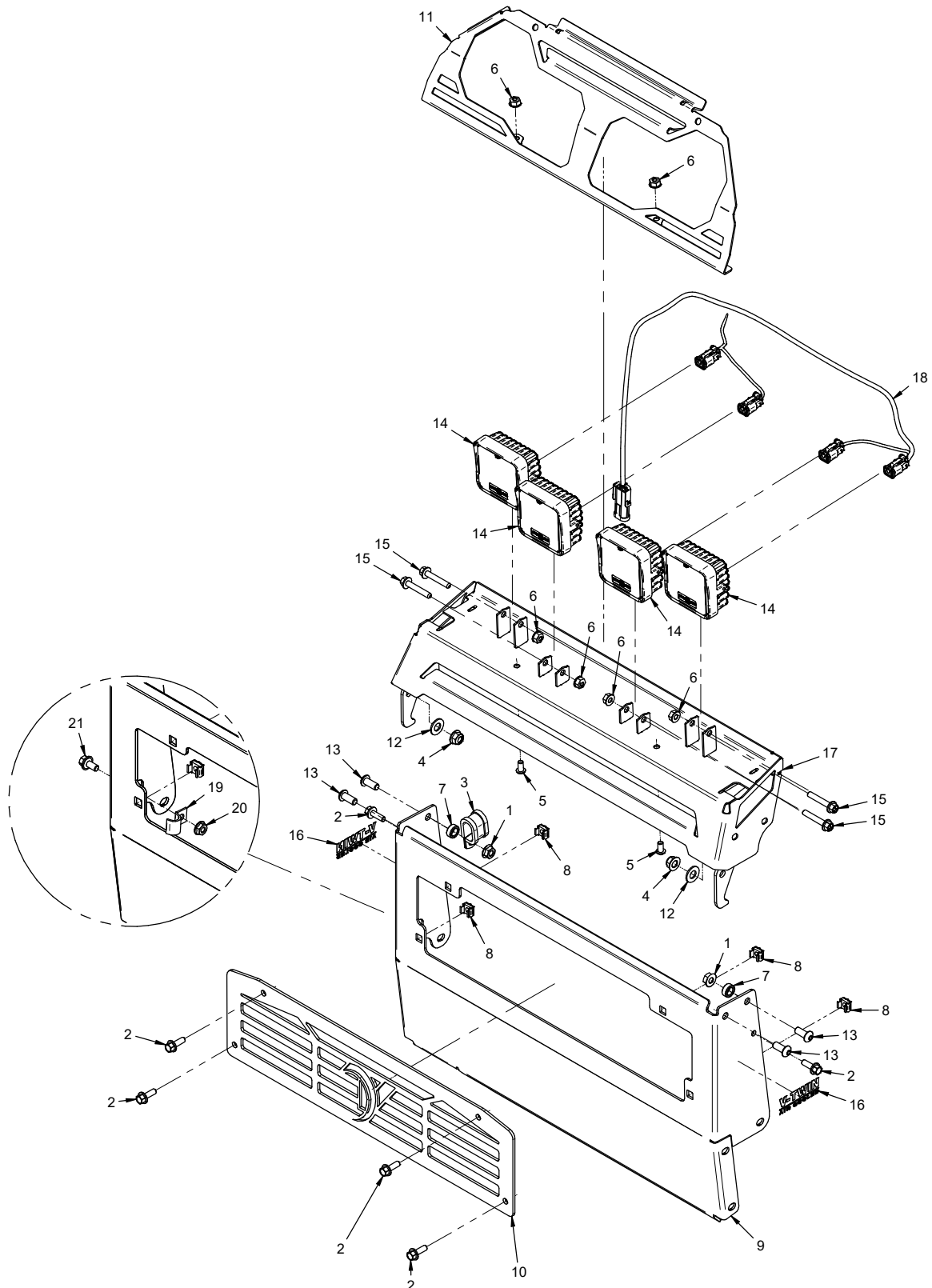

FRAMES / SHEET METAL

Grill & Headlights (Serial # 01001-05664)

REF.	PART NO.	DESCRIPTION	QTY.
1	99.SF05	.Nut, SRF 5/16-18 USS	2
2	99.SF0406-1	.Bolt, SMF 1/4-20 X 3/4	6
3	11.0046	.Clamp, Cushioned 1/2" 2-Tube (Serial # 01001-05425)	1
4	99.E0102	.Nut, Locking Flange 5/16-18	2
5	99.0404	.Bolt, 1/4-20 x 1/2 BSCS	2
6	99.E0101	.Nut, Locking Flange 1/4-20	6
7	64.0602	.Bushing, 3/8 x 5/8 x .265	2
8	99.E0146	.Nut, Cage 1/4-20 (.093 - .126")	4
9	KN-1123	.Bumper, Front, With Short Access Panel	1
10	KN-1191	.Plate, Front Grill "V", Short	1
11	KN-1166	.Grill, Front Filler	1
12	05.0083	.Washer, PVC .375ID x .875 x .0625	2
13	99.0506	.Bolt, 5/16-18 x 3/4 BSCS	4
14	33.0086	.Light, LED Flood	4
15	99.SF0412-1	.Bolt, SMF 1/4-20 x 1-1/2	4
16	00.0320	.Decal, V-Twin (4520K)	2
16	00.0321	.Decal, DFI (4520P)	2
16	00.0322	.Decal, Diesel Liquid Cooled (4520Y)	2
17	KN-6009	.Grill, Front	1
18	32.0234	.Harness, Wire 4520 Hood	1
19	11.0072	.Clamp, 1/2 Loop Vinyl (Serial # 05426-)	1
20	99.SF04	.Nut, SRF 1/4-20 USS (Serial # 05426-)	1
21	99.SF0404-1	.Bolt, SMF 1/4-20 x 1/2 (Serial # 05426-)	1

FRAMES / SHEET METAL

ILLUSTRATED DRAWING Grill & Headlights (Serial # 05665-)

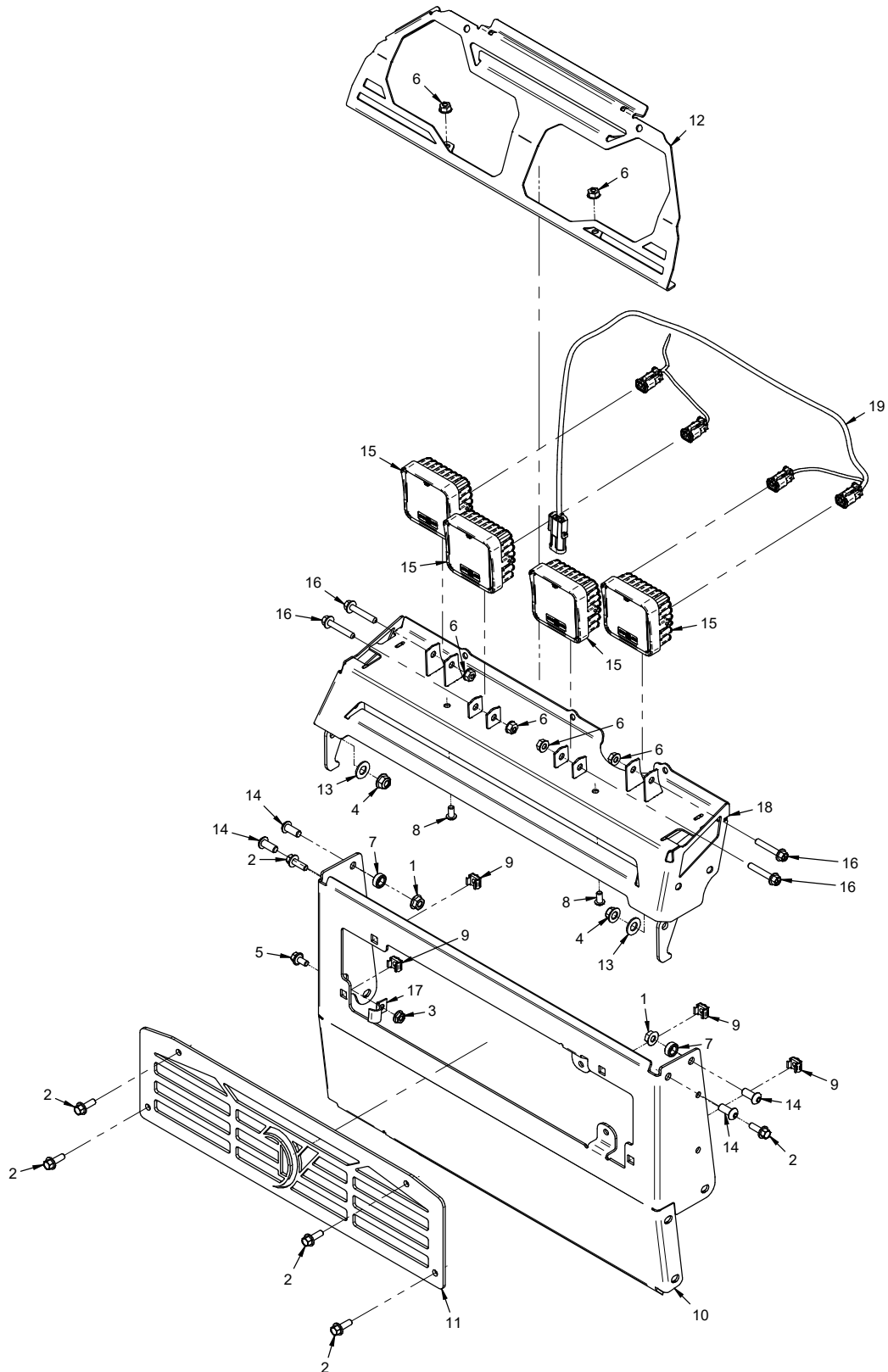

FRAMES / SHEET METAL

Grill & Headlights (Serial # 05665-)

REF.	PART NO.	DESCRIPTION	QTY.
1	99.SF05	Nut, SRF 5/16-18 USS	2
2	99.SF0406-1	Bolt, SMF 1/4-20 X 3/4	6
3	99.SF04	Nut, SRF 1/4-20 USS	1
4	99.E0102	Nut, Locking Flange 5/16-18	2
5	99.SF0404-1	Bolt, SMF 1/4-20 X 1/2	1
6	99.E0101	Nut, Locking Flange 1/4-20	6
7	64.0602	Bushing, 3/8 x 5/8 x .265	2
8	99.0404	Bolt, 1/4-20 x 1/2 BSCS	2
9	99.E0146	Nut, Cage 1/4-20 (.093 - .126")	4
10	KN-1123	Bumper, Front, With Short Access Panel	1
11	KN-1191	Plate, Front Grill "V", Short	1
12	KN-1166	Grill, Front Filler	1
13	05.0083	Washer, PVC .375ID x .875 x .0625	2
14	99.0506	Bolt, 5/16-18 x 3/4 BSCS	4
15	33.0086	Light, LED Flood	4
16	99.SF0412-1	Bolt, SMF 1/4-20 x 1-1/2	4
17	11.0072	Clamp, 1/2 Loop Vinyl	1
18	KN-6058	Grill, Front	1
19	32.0234	Harness, Wire 4520 Hood	1

FRAMES / SHEET METAL

ILLUSTRATED DRAWING

Hood

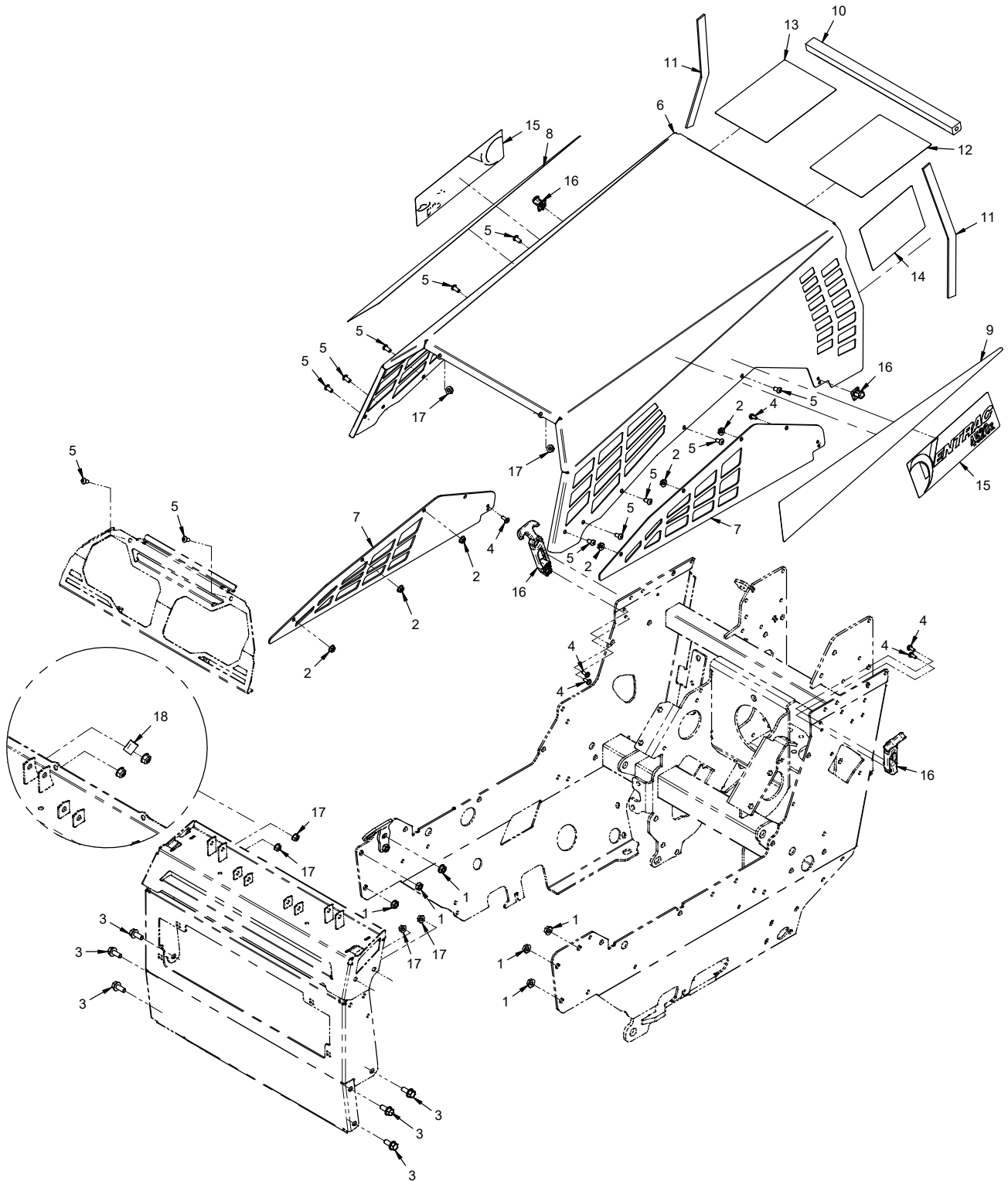

FRAMES / SHEET METAL

Hood

REF.	PART NO.	DESCRIPTION	QTY.
1	99.SF05	Nut, SRF 5/16-18 USS	6
2	99.SF04	Nut, SRF 1/4-20 USS	6
3	99.SF0506-1	Bolt, SMF 5/16-18 USS x 3/4	6
4	99.K0072	Machine Screw, 10-24 X 1/2 ZP	6
5	99.0404	Bolt, 1/4-20 x 1/2 BSCS	12
6	KN-1161	Hood, Engine	1
7	KN-1118	Shield, Hood Lower	2
8	00.0664	Decal, Hood Right	1
9	00.0665	Decal, Hood Left	1
10	44.0421	Seal, Hood Strip 4520	1
11	06.0045-12IN	Weatherstrip, 1/8 X 3/4 X 12"	2
12	00.0670	Decal, Maintenance 4520	1
13	00.0671	Decal, Quick Reference 4520 (Serial # 01001-02232)	1
13	00.0706	Decal, Quick Reference 4520 (Serial # 02232-05658)	1
13	00.0720	Decal, Quick Reference 4520 (Serial # 05659-)	1
14	00.0385	Decal, Maintenance Engine Oil	1
15	00.0652	Decal, Ventrac 4520Y (Serial # 01001-05658)	2
15	00.0653	Decal, Ventrac 4520Z (Serial # 01001-05658)	2
15	00.0654	Decal, Ventrac 4520P (Serial # 01001-05658)	2
15	00.0655	Decal, Ventrac 4520K (Serial # 01001-05658)	2
15	00.0735	Decal, Ventrac (Serial # 05659-)	2
16	47.0127	Latch, Rubber Draw T-Handle	2
17	99.E0101	Nut, Locking Flange 1/4-20	6
18	11.0072	Clamp, 1/2 Loop Vinyl (Serial # 05426-)	1

FRAMES / SHEET METAL

ILLUSTRATED DRAWING

Dash, Dash Brackets, Decals, & Switches (Serial # 01001-05664)

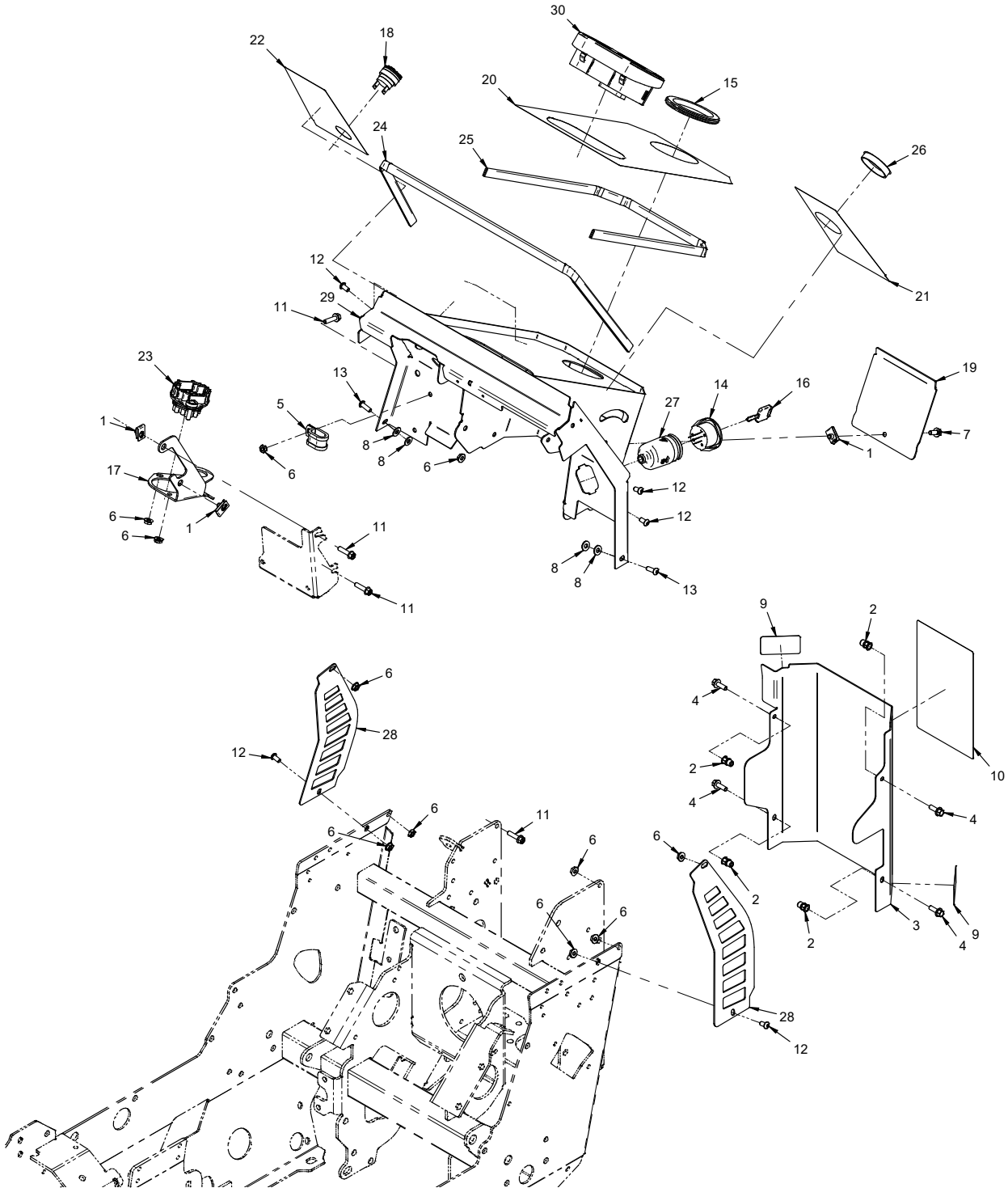

FRAMES / SHEET METAL

Dash, Dash Brackets, Decals, & Switches (Serial # 01001-05664)

REF.	PART NO.	DESCRIPTION	QTY.
1	99.E0046	Nut, "U" 1/4-20 Extruded	3
2	99.E0105	Nut, Insert 1/4-20 Hex	4
3	KN-1026	Cover, Pump	1
4	99.SF0406-1	Bolt, SMF 1/4-20 X 3/4	4
5	11.0046	Clamp, Cushioned 1/2" 2-Tube	1
6	99.SF04	Nut, SRF 1/4-20 USS	11
7	99.SF0405-1	Bolt, SMF 1/4-20 X 5/8	1
8	95.04	Washer, Flat 1/4 SAE	4
9	00.0639	Decal, Pinching Hazard Foot	2
10	00.0642	Decal, Slope Warning	1
11	99.SF0408-1	Bolt, SMF 1/4-20 x 1	4
12	99.0404	Bolt, 1/4-20 x 1/2 BSCS	5
13	99.0406	Bolt, 1/4-20 x 3/4 BSCS	2
14	13.0078	Switch, Ignition Delta	1
15	05.0080	Grommet, 2-3/4 ID, 3-5/8 OD, 5/16T	1
16	13.0080	Key, Ignition Delta	1
17	64.1691	Bracket, Harness Connector	1
18	35.0124	Alarm, Audible Cont. Panel Mt	1
19	KN-1144	Cover, Steering Valve	1
20	00.0684	Decal, Dash Center	1
21	00.0683	Decal, Dash Left	1
22	00.0685	Decal, Dash Right	1
23	30.0351	Connector, 22 Pos Wpak Female	1
24	06.0042-33.5IN	Trim, Trim Loc 1/2 x 1/16 x 33-1/2"	1
25	06.0042-34.88IN	Trim, Trim Loc 1/2 x 1/16 x 34-7/8"	1
26	05.0058	Plug, 2" Hole, Nylon	1
27	30.0469	Cover, Splashguard Ig Switch	1
28	KN-1136	Panel, Dash Access	2
29	KN-6019	Dash, Main Panel	1
30	35.0159	Gauge, Cluster Information	1

FRAMES / SHEET METAL

ILLUSTRATED DRAWING Dash, Dash Brackets, Decals, & Switches (Serial # 05665-)

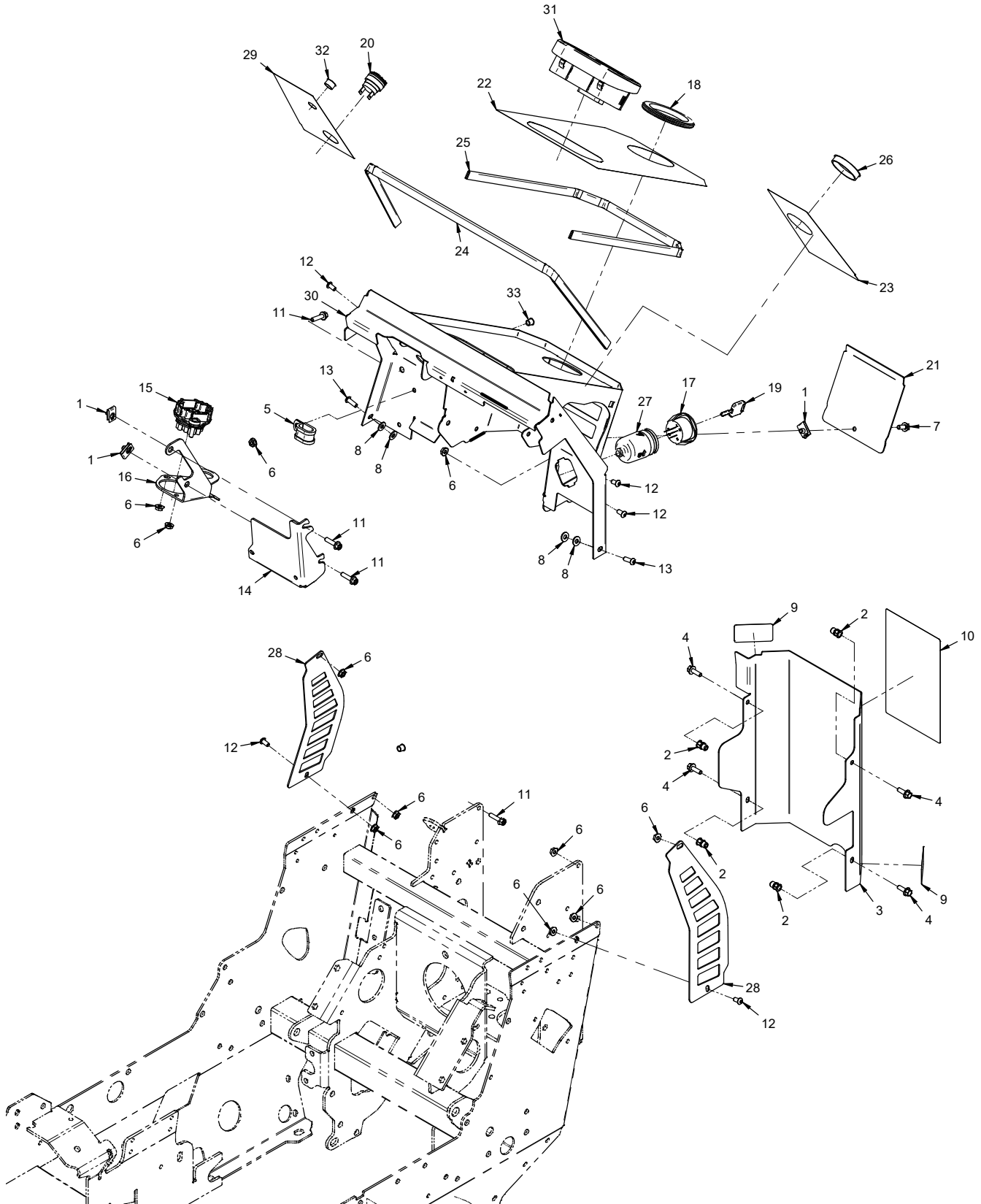

FRAMES / SHEET METAL

Dash, Dash Brackets, Decals, & Switches (Serial # 05665-)

REF.	PART NO.	DESCRIPTION	QTY.
1	99.E0046	Nut, "U" 1/4-20 Extruded	3
2	99.E0105	Nut, Insert 1/4-20 Hex	4
3	KN-1026	Cover, Pump	1
4	99.SF0406-1	Bolt, SMF 1/4-20 X 3/4	4
5	11.0046	Clamp, Cushioned 1/2" 2-Tube	1
6	99.SF04	Nut, SRF 1/4-20 USS	11
7	99.SF0405-1	Bolt, SMF 1/4-20 X 5/8	1
8	95.04	Washer, Flat 1/4 SAE	4
9	00.0639	Decal, Pinching Hazard Foot	2
10	00.0642	Decal, Slope Warning	1
11	99.SF0408-1	Bolt, SMF 1/4-20 x 1	4
12	99.0404	Bolt, 1/4-20 x 1/2 BSCS	5
13	99.0406	Bolt, 1/4-20 x 3/4 BSCS	2
14	64.1690	Bracket, TCM	1
15	30.0351	Connector, 22 Pos Wpak Female	1
16	64.1691	Bracket, Harness Connector	1
17	13.0078	Switch, Ignition Delta	1
18	05.0080	Grommet, 2-3/4 ID, 3-5/8 OD, 5/16T	1
19	13.0080	Key, Ignition Delta	1
20	35.0124	Alarm, Audible Cont. Panel Mt	1
21	KN-1144	Cover, Steering Valve	1
22	00.0684	Decal, Dash Center	1
23	00.0683	Decal, Dash Left	1
24	06.0042-33.5IN	Trim, Trim Loc 1/2 x 1/16 x 33-1/2"	1
25	06.0042-34.88IN	Trim, Trim Loc 1/2 x 1/16 x 34-7/8"	1
26	05.0058	Plug, 2" Hole, Nylon	1
27	30.0469	Cover, Splashguard Ig Switch	1
28	KN-1136	Panel, Dash Access	2
29	00.0733	Decal, Dash Right	1
30	KN-6062	Dash, Main Panel	1
31	35.0159	Gauge, Cluster Information	1
32	05.0139	Plug, 5/8" Hole, Blk Plastic (4520K, 4520P, 4520Y, & 4520Z)	1
33	05.0087	Plug, 3/8" Hole, Black (4520N, 4520P, & 4520Y)	1

CONTROLS & LINKAGE

SDLA Control Levers

REF.	PART NO.	DESCRIPTION	QTY.
1	99.SF05	Nut, SRF 5/16-18 USS	2
2	99.SF04	Nut, SRF 1/4-20 USS	1
3	99.SF0404-1	Bolt, SMF 1/4-20 X 1/2	3
4	60.1120	Cover, SDLA Pivot	1
5	79.0091	Brush, SDLA Cover w/Holder	2
6	99.SF0404	Bolt, SRF 1/4-20 X 1/2	2
7	99.A04N	Locknut, Nylon 1/4-20	6
8	99.E0101	Nut, Locking Flange 1/4-20	4
9	99.SF0408-1	Bolt, SMF 1/4-20 x 1	4
10	23.0201	Valve, 2 Spool W/LH Flt, RH SP	1
11	99.SF0516-1	Bolt, SMF 5/16-18 x 2	2
12	42.0605	Rod, Thread 1/4-28 x 6.50 RH/LH	2
13	99.E0081	Nut, 1/4-28 LH Grade 8 YZ	2
14	93.04	Nut, 1/4-28 SAE	2
15	96.04	Washer, Lock 1/4	2
16	90.0410	Bolt, 1/4-20 USS x 1/1-4"	2
17	85.B0027	Bushing, 1/2 ID X 5/8 OD X 5/8	4
18	55.FB16008	Bearing, Flange Block 1/2"	1
19	99.A08N	Locknut, Nylon 1/2-13 USS	1
20	40.0240	Handle, F/R Control ZP	2
21	47.0329	Knob, Round 1-3/8" x 1/2-13	1
22	47.0003	Knob, Round 2" x 1/2-13	1
23	99.A04NFN	Locknut, Nylon 1/4-28	2
24	92.08-4	Nut, 1/2-13 Yellow ZP	2
25	85.SC08	Set Collar, 1/2"	2
26	85.SS19	Set Screw, 1/4-20 x 1/4"	2
27	43.004S	Rod End, 1/4 Spherical w/Stud	2
28	43.004L	Rod End, 1/4 Spherical LH	2
29	55.0081	Bearing, Flange Iigus 5/8"	1
30	KN-6005	Arm, SDLA Pivot	1
31	42.0562	Pivot, SDLA Lever	2

CONTROLS & LINKAGE

ILLUSTRATED DRAWING

SDLA Linkage

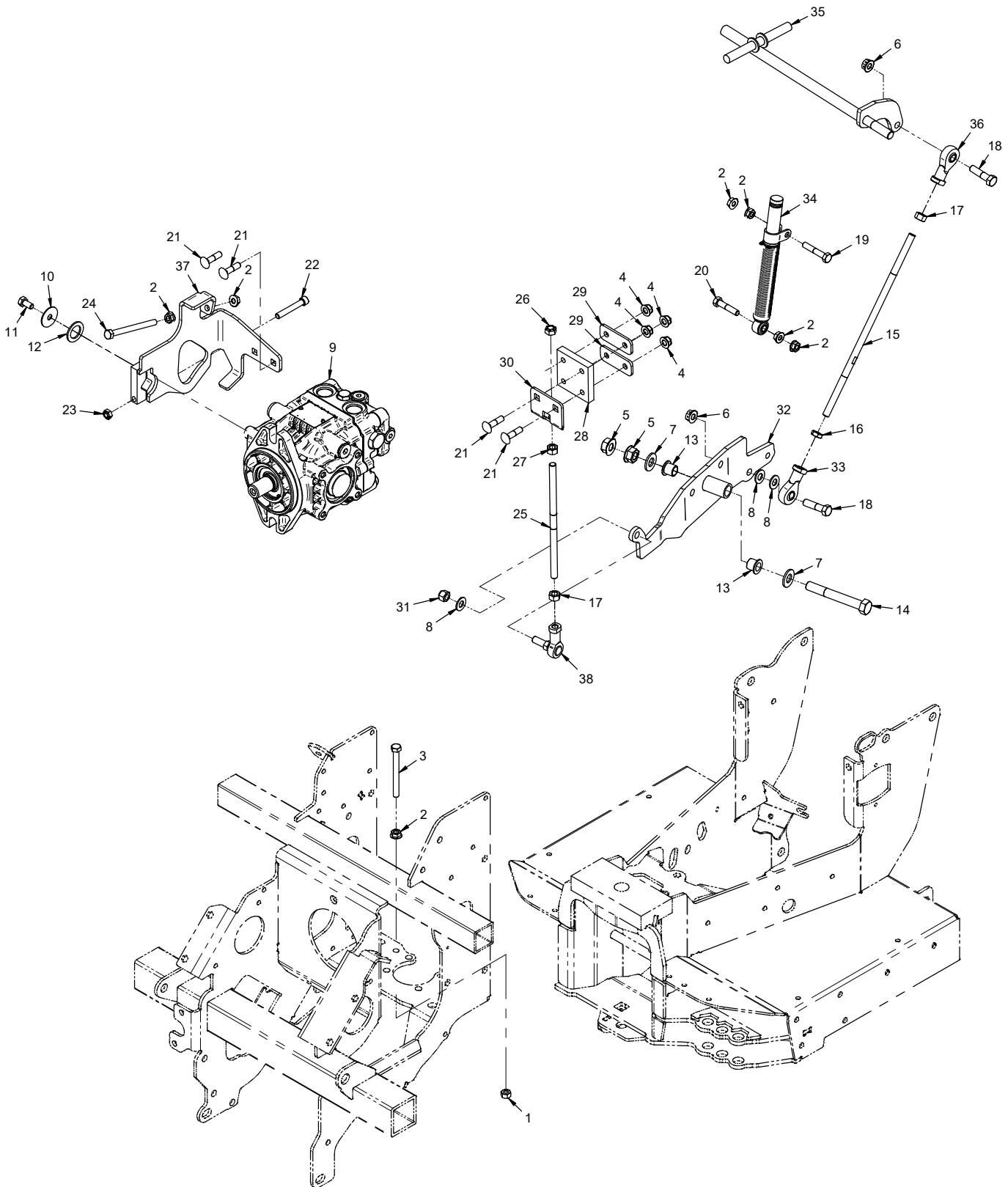

CONTROLS & LINKAGE

SDLA Linkage

REF.	PART NO.	DESCRIPTION	QTY.
1	92.05	Nut, 5/16-18 USS	1
2	99.SF05	Nut, SRF 5/16-18 USS	7
3	90.0526-2	Bolt, 5/16-18 x 3-1/4 Tap.	1
4	99.E0102	Nut, Locking Flange 5/16-18	4
5	99.SF08	Nut, SRF 1/2-13 USS	2
6	99.E0082	Nut, Locking Flange 3/8-16	2
7	95.08	Washer, Flat 1/2 SAE	2
8	95.06	Washer, Flat 3/8 SAE	4
9	21.0148	Pump, Hyd. Danfoss 20cc	1
10	99.B0118	Washer, Fender 5/16 X 1-1/4	1
11	99.M0014	Bolt, M8 x 1.25 x 16mm	1
12	05.0197	Washer, Nylon .812 ID x 1.25 OD x .080	1
13	85.B0027	Bushing, 1/2 ID X 5/8 OD X 5/8	2
14	90.0830	Bolt, Hex 1/2-13 UNC x 3-3/4	1
15	42.0604	Rod, Thread 3/8-24 X 11.50" RH/LH ZP.	1
16	99.E0083	Nut, Jam 3/8-24 SAE LH ZP	1
17	93.06	Nut, Hex 3/8-24 UNF.	2
18	90.0612	Bolt, 3/8-16 USS x 1-1/2	2
19	90.0514	Bolt, Hex 5/16-18 UNC x 1-3/4"	1
20	90.0512	Bolt, 5/16-18 USS x 1-1/2"	1
21	97.0510	Bolt, Carriage 5/16 x 1-1/4	4
22	99.K0123	Bolt, SHCS 5/16-18 x 2 Grade 8	1
23	99.A05	Locknut, Stover 5/16-18 USS	1
24	90.0530-2	Bolt, 5/16-18 x 3-3/4 Tap.	1
25	KN-1106	Rod, Thread 3/8-24 X 8" RH/RH ZP	1
26	99.E0107	Locknut, 3/8-24 LH ZP.	1
27	99.E0114	Nut, 3/8-24 LH ZP	1
28	44.0161	Link, Tubber for Shift Linkage	1
29	64.0763	Clamp, Rubber Connector	2
30	64.0764	Bracket, Pump Control Link Long	1
31	99.A06NFN	Locknut, Nylon 3/8-24 SAE ZP	1
32	KN-6006	Arm, SDLA Rocker	1
33	43.006L	Rod End, 3/8 Spherical, LH Thrd	1
34	47.0316	Damper, 3.187 Stroke Gas Shock	1
35	KN-6005	Arm, SDLA Pivot	1
36	43.006	Rod End, 3/8 Spherical, Female	1
37	KN-6004	Bracket, Pump Input	1
38	43.006S	Rod End, 3/8 Spherical W/ Stud	1

CONTROLS & LINKAGE

ILLUSTRATED DRAWING

Neutral Assist Lever & Neutral Switch

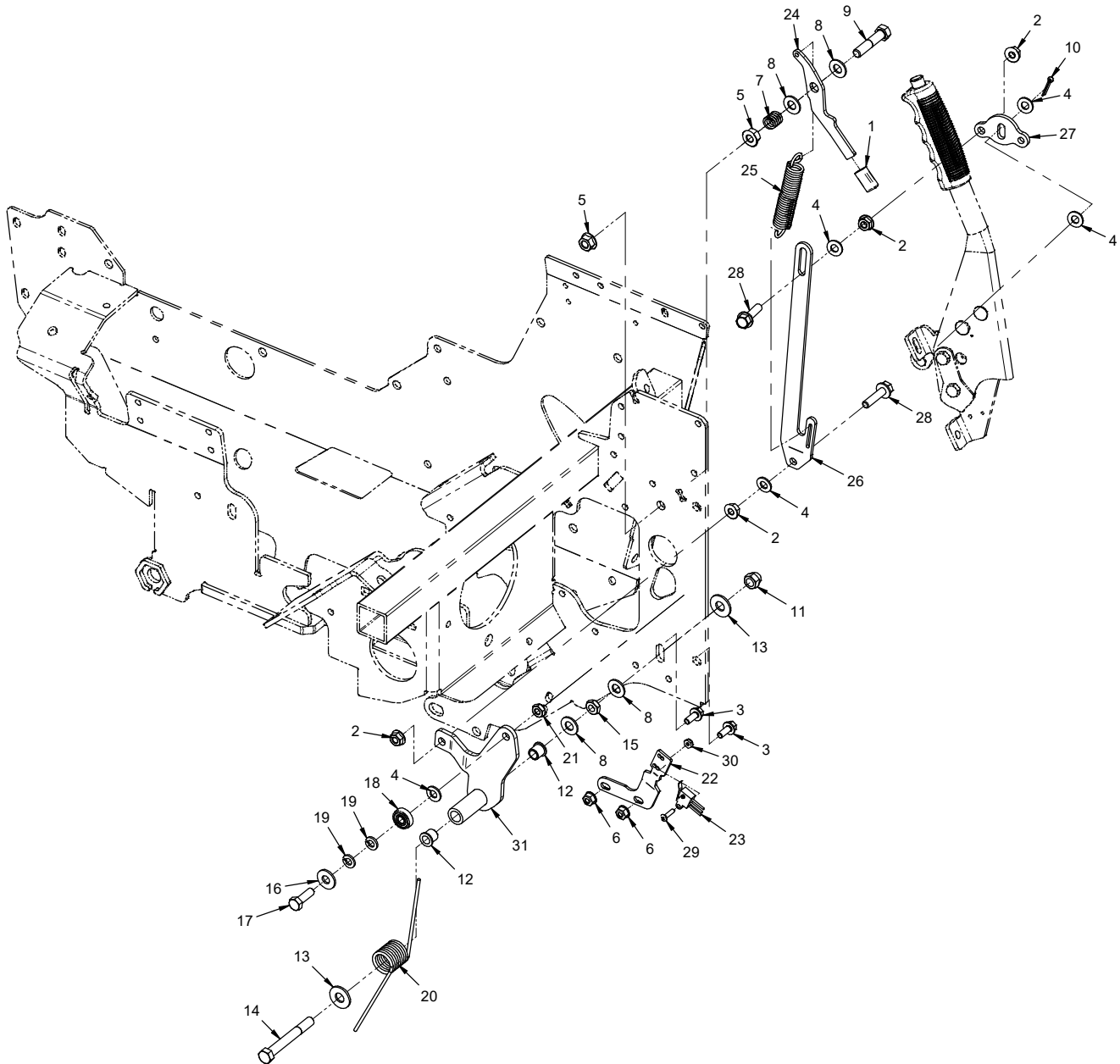

CONTROLS & LINKAGE

Neutral Assist Lever & Neutral Switch

REF.	PART NO.	DESCRIPTION	QTY.
1	06.0044	Cap, Plastic 1/8 x 1/2 x 7/8	1
2	99.SF05	Nut, SRF 5/16-18 USS	4
3	99.SF0405-1	Bolt, SMF 1/4-20 X 5/8	2
4	95.05	Washer, Flat 5/16 SAE	5
5	99.SF06	Nut, SRF 3/8-16 USS	2
6	99.E0101	Nut, Locking Flange 1/4-20	2
7	41.0039	Spring, Comp. 9/16 OD X 5/8	1
8	95.06	Washer, Flat 3/8 SAE	4
9	90.0614	Bolt, 3/8-16 USS x 1-3/4	1
10	02.CP0406	Cotter Pin, 1/8 X 3/4, Zinc	1
11	99.E0100	Nut, Acorn 3/8-16	1
12	85.B0068	Bushing, 3/8 X 1/2 OD X 1/2 LG	2
13	94.06	Washer, Flat 3/8 USS	2
14	90.0624	Bolt, 3/8-16 USS x 3	1
15	99.E0037	Nut, Jam 3/8-16 USS	1
16	94.05	Washer, Flat 5/16 USS	1
17	90.0508	Bolt, 5/16-18 USS x 1	1
18	55.0022	Bearing, Ball .315 ID X .8661 OD	1
19	96.05	Washer, Lock 5/16	2
20	41.0105	Spring, Torsion LH .83"ID SS	1
21	99.E0109	Nut, Jam 5/16-18 Nylon Lock	1
22	64.1652	Bracket, Neutral Switch Mount	1
23	31.0058-2	Switch, Micro Neutral	1
24	40.0374	Lever, Neutral Assist	1
25	41.0106	Spring, Ext 3/4 OD X 4 LG	1
26	42.0556	Link, Neutral Assist	1
27	64.1626	Rocker, Park Brake Tensioner	1
28	99.SF0510-1	Bolt, SMF 5/16-18 USS X 1-1/4	2
29	99.K0133	Machine Screw, #8-32 X 5/8	1
30	99.E0104	Nut, Jam #8-32 Nylon Lock	1
31	KN-6002	Rocker, Neutral Assist	1

CONTROLS & LINKAGE

ILLUSTRATED DRAWING

Parking Brake Handle, Brake Rod, & Shields

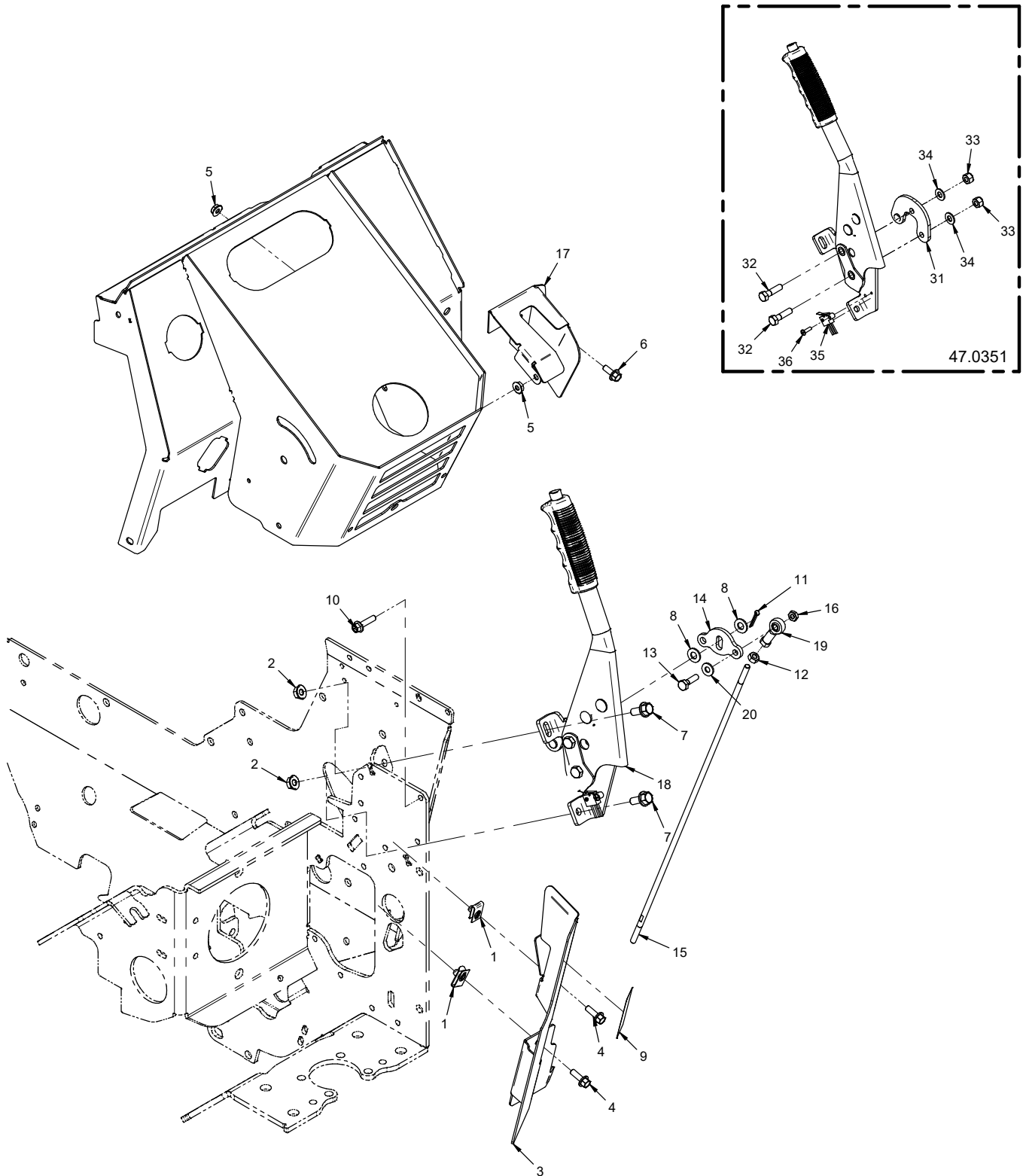

CONTROLS & LINKAGE

Parking Brake Handle, Brake Rod, & Shields

REF.	PART NO.	DESCRIPTION	QTY.
1	99.E0046	Nut, "U" 1/4-20 Extruded	2
2	99.SF05	Nut, SRF 5/16-18 USS	2
3	60.1151	Cover, Pump Access Right	1
4	99.SF0406-1	Bolt, SMF 1/4-20 X 3/4	2
5	99.SF04	Nut, SRF 1/4-20 USS	2
6	99.SF0405-1	Bolt, SMF 1/4-20 X 5/8	1
7	99.SF0506-1	Bolt, SMF 5/16-18 USS x 3/4	2
8	95.05	Washer, Flat 5/16 SAE	2
9	00.0318	Decal, Neutral Assist	1
10	99.SF0408-1	Bolt, SMF 1/4-20 x 1	1
11	02.CP0406	Cotter Pin, 1/8 X 3/4, Zinc	1
12	99.E0081	Nut, 1/4-28 LH Grade 8 YZ	1
13	90.0408	Bolt, 1/4-20 USS x 1	1
14	64.1626	Rocker, Park Brake Tensioner	1
15	42.0551	Rod, Thread 1/4-28 x 20" RH/LH	1
16	99.A04	Locknut, Stover 1/4-20 USS	1
17	60.1142	Cover, Parking Brake	1
18	47.0351	Lever, Parking Brake	1
19	43.004L	Rod End, 1/4 Spherical LH	1
20	95.04	Washer, Flat 1/4 SAE	1
31	64.1633	Mount, Park Brake Rocker	1
32	91.0510	Bolt, Hex 5/16-24 UNF x 1-1/4	2
33	99.A05NFN	Locknut, Nylon 5/16-24 SAE ZP	2
34	95.05	Washer, Flat 5/16 SAE	2
35	31.0058-1	Switch, Micro Parking Brake	1
36	99.M0033	Machine Screw, M4-0.7 x 14MM	1

CONTROLS & LINKAGE

Parking Brake Linkage & Brake Drum

REF.	PART NO.	DESCRIPTION	QTY.
1	99.E0102	Nut, Locking Flange 5/16-18	2
2	95.05	Washer, Flat 5/16 SAE	2
3	99.SF06	Nut, SRF 3/8-16 USS	4
4	99.E0082	Nut, Locking Flange 3/8-16	4
5	95.04	Washer, Flat 1/4 SAE	1
6	95.06	Washer, Flat 3/8 SAE	8
7	90.0610	Bolt, 3/8-16 USS x 1-1/4	1
8	99.A04NFN	Locknut, Nylon 1/4-28	1
9	90.0408	Bolt, 1/4-20 USS x 1	2
10	64.1614	Plate, Brake Anchor Inner	1
11	64.0718	Spacer, Brake	2
12	64.0920	Plate, Park Bk Mount Alignment	1
13	90.0616	Bolt, 3/8-16 USS x 2	3
14	53.0076	Band, Brake for 6" Drum	1
15	90.0516	Bolt, 5/16-18 USS x 2	2
16	42.0441	Link, Park BK Pull	1
17	42.0442	Link, Park BK Push	1
18	64.1603	Rocker, Park Brake	1
19	42.0443	Link, Park BK Torque	1
20	85.SC06	Set Collar, 3/8"	2
21	90.0608	Bolt, 3/8-16 USS x 1	1
22	42.0551	Rod, Thread 1/4-28 x 20" RH/LH	1
23	41.0108	Spring, Comp. .531 OD X .780 LG	1
24	83.H16S-2	Bushing, 1" Split 3/16 * & 1/4 Key	1
25	99.SF0606	Bolt, SRF 3/8-16 USS x 3/4	2
26	85.W0306	Key, Woodruff 3/16 X 3/4	1
27	53.0134	Drum, 6" Brake - W/Taper Hub	1

CONTROLS & LINKAGE

ILLUSTRATED DRAWING

High/Low Range Shift Linkage

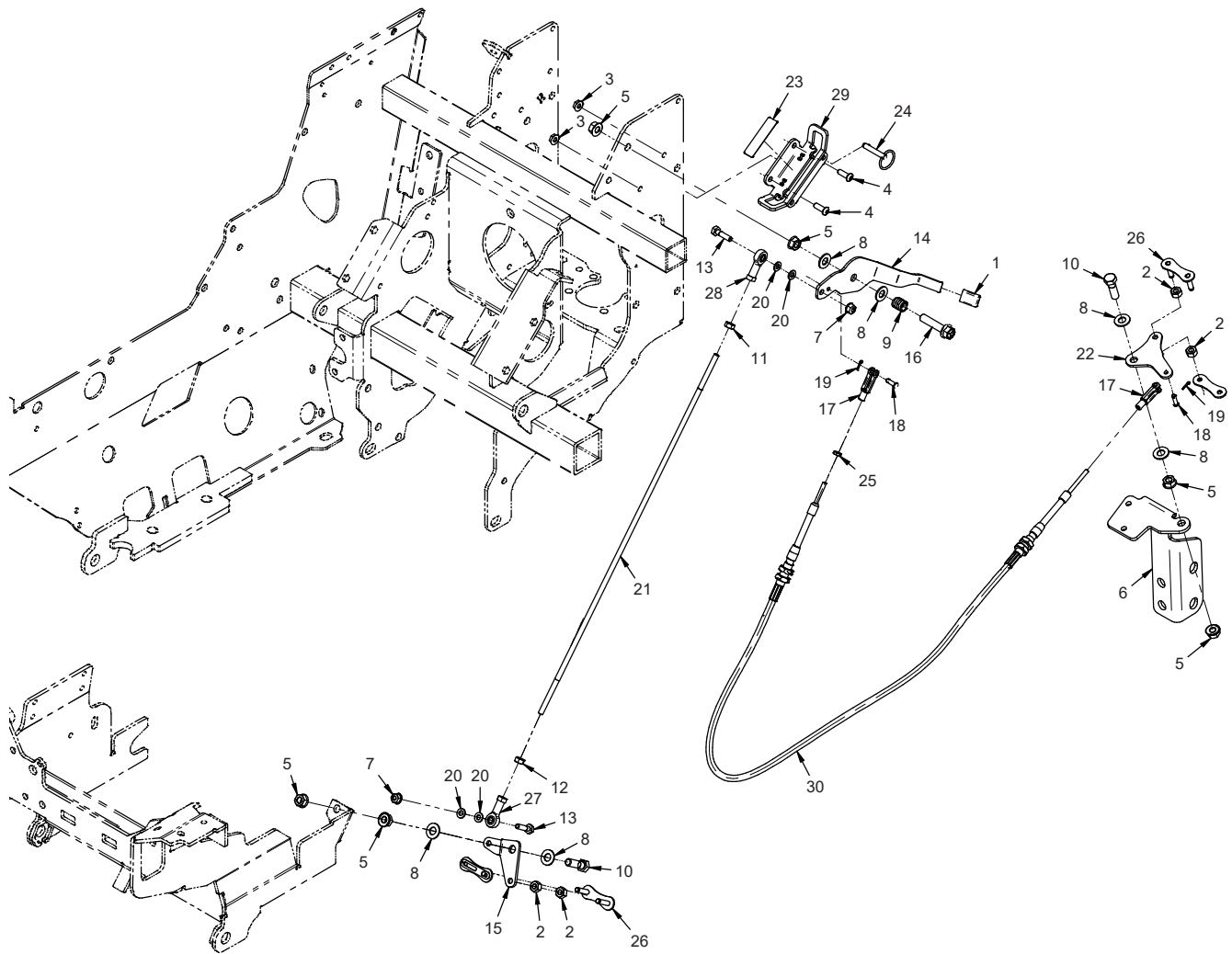

CONTROLS & LINKAGE

High/Low Range Shift Linkage

REF.	PART NO.	DESCRIPTION	QTY.
1	06.0044	.Cap, Plastic 1/8 x 1/2 x 7/8	1
2	92.05	.Nut, 5/16-18 USS	4
3	99.SF04	.Nut, SRF 1/4-20 USS	2
4	99.0406	.Bolt, 1/4-20 x 3/4 BSCS	2
5	99.SF06	.Nut, SRF 3/8-16 USS	6
6	KN-1032	.Bracket, Rear Hitch Mt Right	1
7	99.E0101	.Nut, Locking Flange 1/4-20	2
8	95.06	.Washer, Flat 3/8 SAE	6
9	41.0039	.Spring, Comp. 9/16 OD X 5/8	1
10	90.0610	.Bolt, 3/8-16 USS x 1-1/4	2
11	99.E0081	.Nut, 1/4-28 LH Grade 8 YZ	1
12	93.04	.Nut, 1/4-28 SAE	1
13	90.0408	.Bolt, 1/4-20 USS x 1	2
14	40.0379	.Lever, High/Low Shift	1
15	64.0703	.Plate, Front Shift Pivot	1
16	99.SF0614-1	.Bolt, SMF 3/8-16 X 1-3/4	1
17	43.C10-32-1	.Clevis End Kit, #10-32 3/16 Hole	2
18	03.0305	.Clevis Pin, 3/16 x 5/8 ZP	2
19	02.CP0204	.Cotter Pin, 1/16 X 1/2, Zinc	2
20	99.B0109	.Washer, 1/4ID, .50 OD x .062T	4
21	42.0561	.Rod, Thread 1/4-28x21.00 RH/LH	1
22	40.0373	.Arm, High/Low Shift Rocker	1
23	00.0313	.Decal, High/Low Range	1
24	03.0022	.Pin, Ball 1/4" x 1"	1
25	99.E0034	.Nut, #10-32	1
26	81.0124	.Link, Conn #60 Double Pitch	2
27	43.004	.Rod End, 1/4 Spherical	1
28	43.004L	.Rod End, 1/4 Spherical LH	1
29	64.1784	.Bracket, High/Low Shift Lock	1
30	47.0122	.Cable, Hi-Low Shift	1

CONTROLS & LINKAGE

ILLUSTRATED DRAWING PTO Idler Pulley & Idler Arm

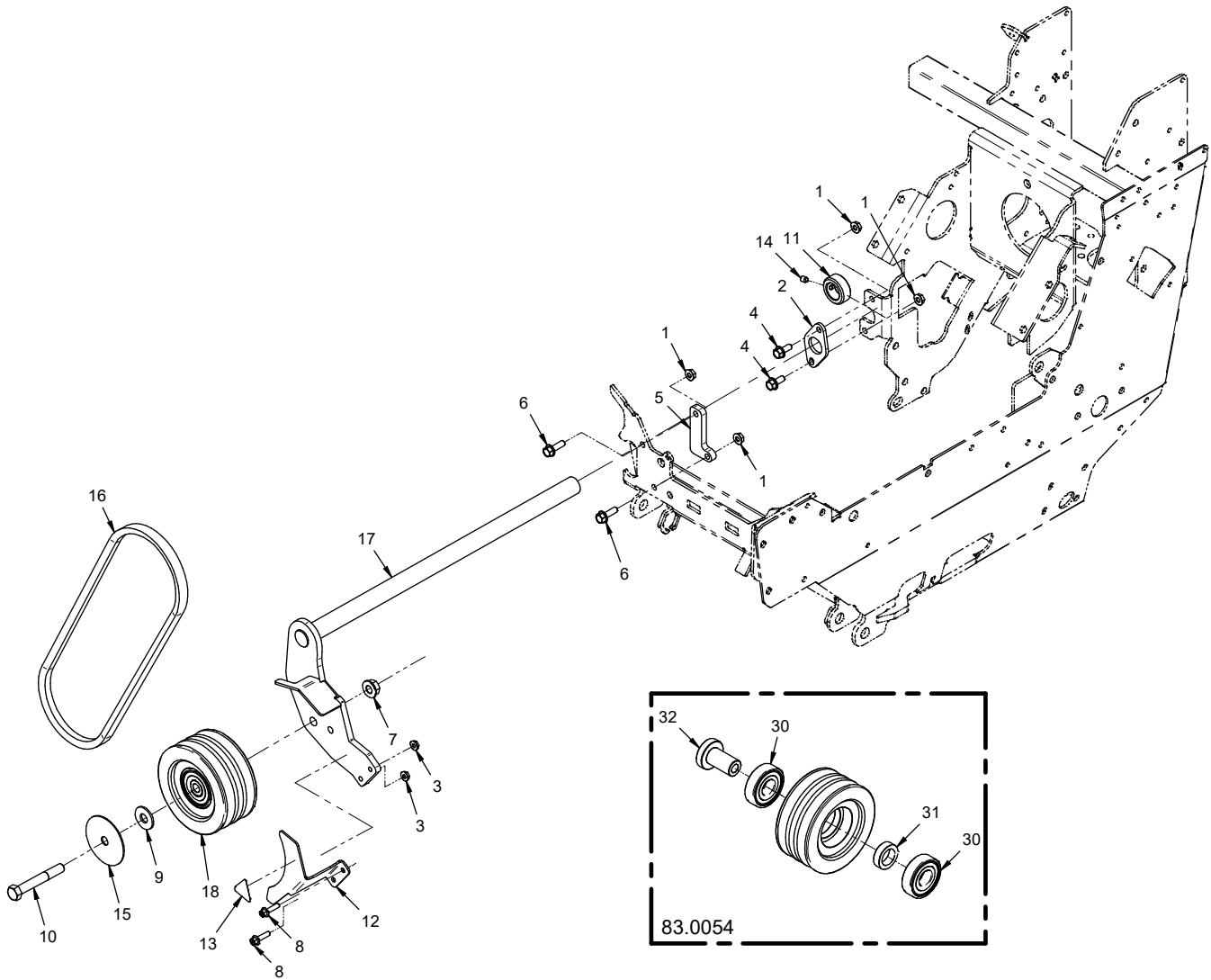

CONTROLS & LINKAGE

PTO Idler Pulley & Idler Arm

REF.	PART NO.	DESCRIPTION	QTY.
1	99.SF05	Nut, SRF 5/16-18 USS	4
2	64.1702	Plate, PTO Arm Hanger	1
3	99.SF04	Nut, SRF 1/4-20 USS	2
4	99.SF0506-1	Bolt, SMF 5/16-18 USS X 3/4	2
5	64.1699	Plate, PTO Wearbar	1
6	99.SF0508-1	Bolt, SMF 5/16-18 x 1	2
7	99.E0103	Nut, Locking Flange 1/2-13	1
8	99.SF0408-1	Bolt, SMF 1/4-20 x 1	2
9	94.08	Washer, Flat 1/2 USS	1
10	90.0828	Bolt, 1/2-13 USS x 3-1/2	1
11	85.SC16-1	Set Collar, 1.015"	1
12	60.1135	Guard, PTO Idler Pulley	1
13	00.0339	Decal, Moving Parts	1
14	85.SS18	Set Screw, 5/16-18 x 3/8	1
15	60.1279	Cover, Pulley	1
16	81.B038	Belt, B38	1
17	40.0378	Arm, PTO Idler	1
18	83.0054	Pulley, Idler 2 Groove Asm	1
30	55.0064	Bearing, Ball 25 MM x 62 MM	2
31	85.B0085	Bushing, Bearing Spacer	1
32	85.B0084	Bushing, Drive Pulley	1

CONTROLS & LINKAGE

ILLUSTRATED DRAWING PTO Belt Tension Linkage

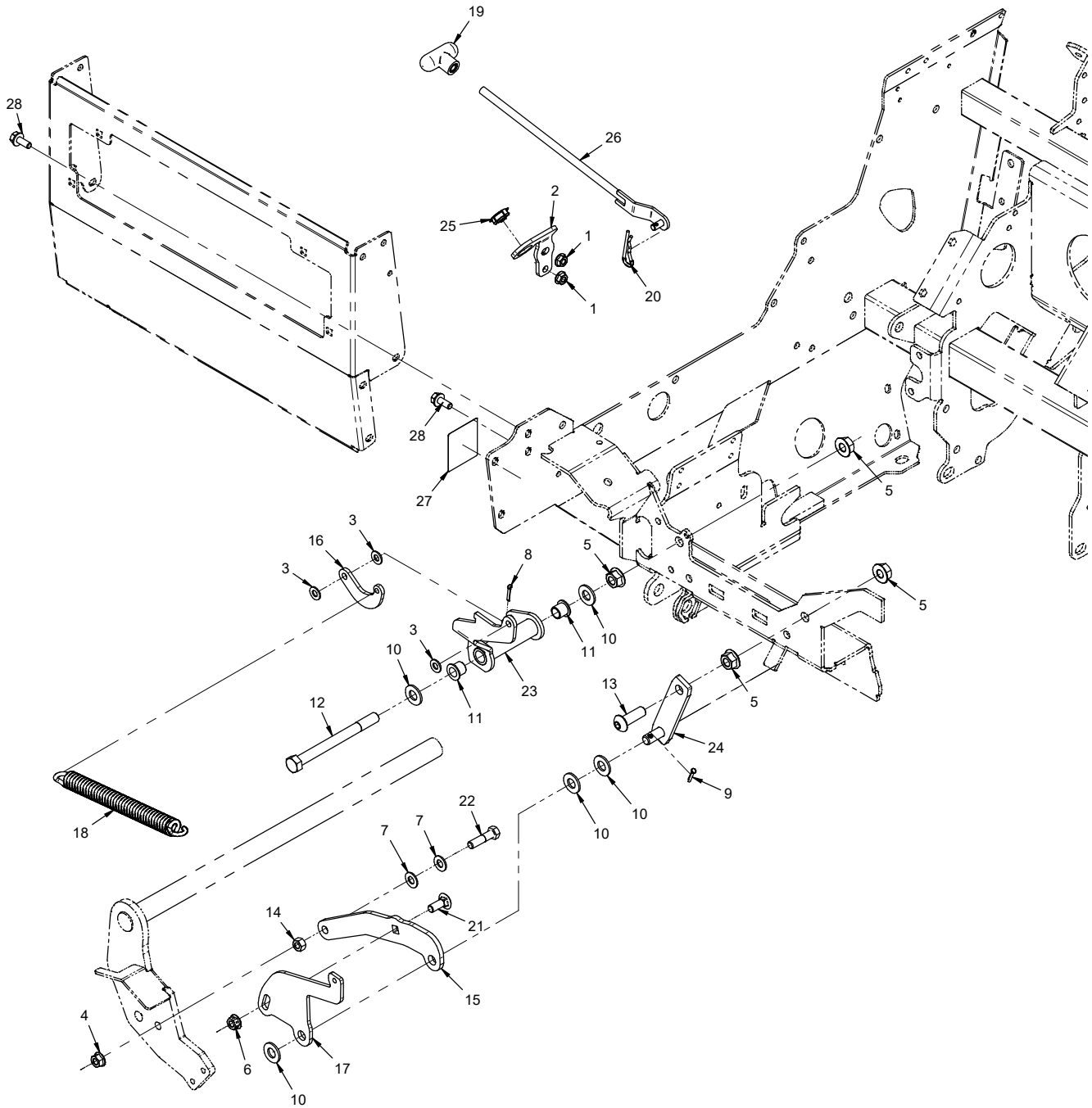

CONTROLS & LINKAGE

PTO Belt Tension Linkage

REF.	PART NO.	DESCRIPTION	QTY.
1	99.SF05	Nut, SRF 5/16-18 USS	2
2	64.1616	Bracket, Belt Release Pivot	1
3	95.05	Washer, Flat 5/16 SAE	3
4	99.SF06	Nut, SRF 3/8-16 USS	1
5	99.SF08	Nut, SRF 1/2-13 USS	4
6	99.E0082	Nut, Locking Flange 3/8-16	1
7	95.06	Washer, Flat 3/8 SAE	2
8	02.CP0406	Cotter Pin, 1/8 X 3/4, Zinc	1
9	02.CP0506	Cotter Pin, 5/32 X 3/4, Zinc	1
10	95.08	Washer, Flat 1/2 SAE	5
11	85.B0027	Bushing, 1/2 ID X 5/8 OD X 5/8	2
12	90.0844	Bolt, 1/2-13 USS x 5-1/2	1
13	99.0812	Bolt, 1/2-13 x 1-1/2 BSCS	1
14	92.06	Nut, 3/8-16 USS	1
15	42.0584	Link, PTO Idler Push Arm	1
16	42.0557	Link, PTO Belt Tensioner	1
17	42.0559	Link, PTO Tensioner Adjuster	1
18	41.0056	Spring, Ext 7/8 OD x 8-1/2 Lng	1
19	47.0330	Knob, Bar 2-1/4 x 3/8-16	1
20	02.HP0416	Hairpin, 1/8 X 2 ZP	1
21	97.0608	Bolt, Carriage 3/8-16 x 1	1
22	90.0612	Bolt, 3/8-16 USS x 1-1/2	1
23	64.1627	Rocker, PTO Idler Arm Tension	1
24	64.1610	Rocker, PTO Tensioner	1
25	55.0082	Bearing, Spherical 10MM ID	1
26	42.0554	Rod, PTO Belt Tensioner	1
27	00.0319	Decal, PTO Tension	1
28	99.SF0506-1	Bolt, SMF 5/16-18 USS x 3/4	2

CONTROLS & LINKAGE

ILLUSTRATED DRAWING

Weight Transfer

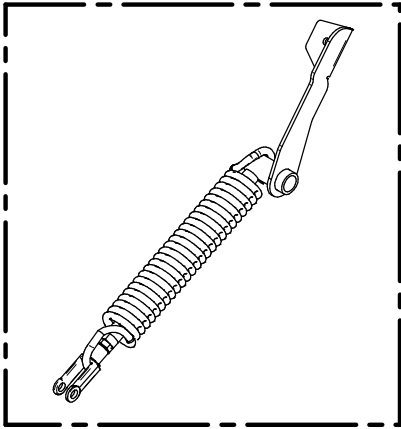

Individual components of Weight Transfer Arm not available for service. Order kit #70.4115 and follow the kit instructions to replace with pre-assembled components.

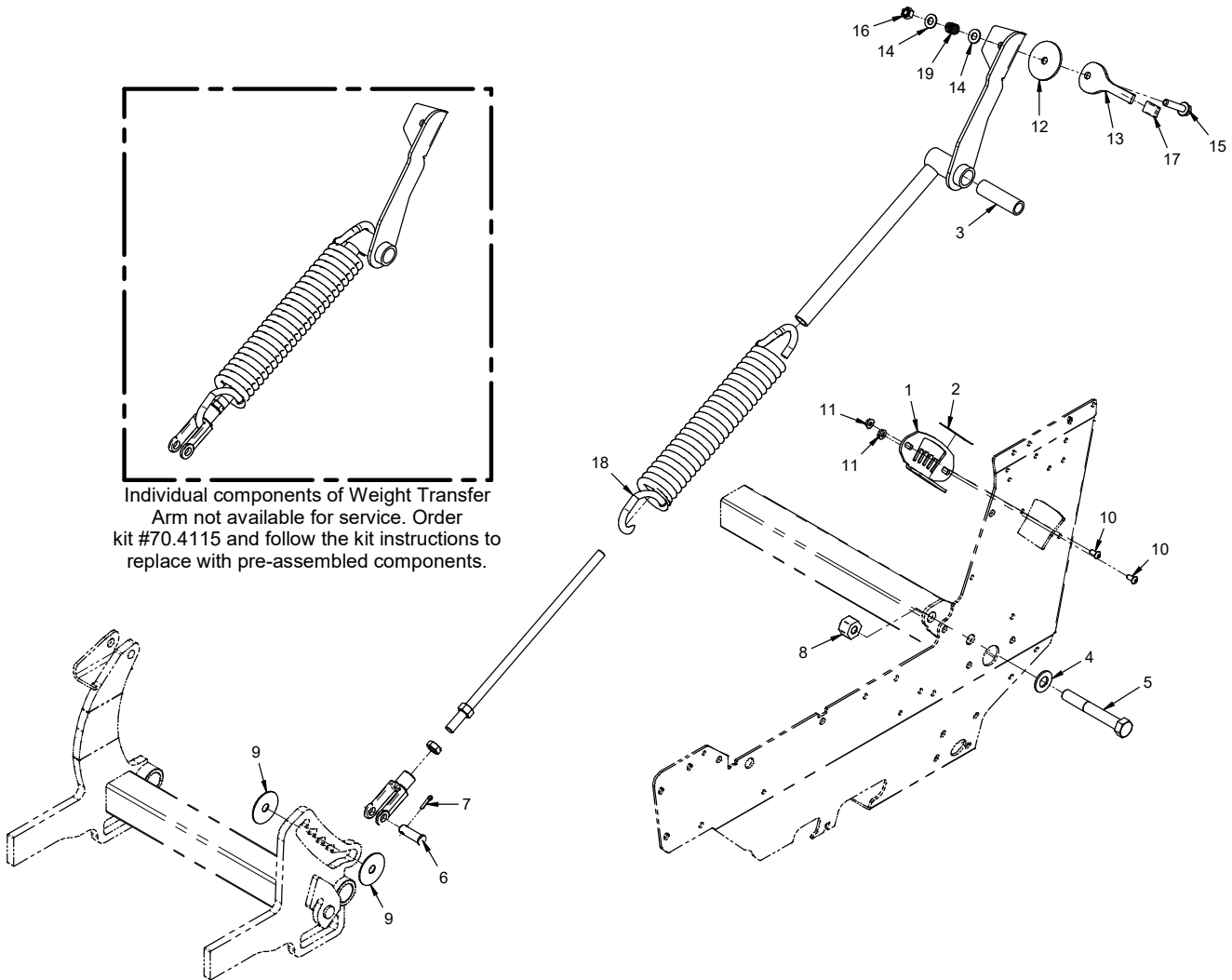

CONTROLS & LINKAGE

Weight Transfer

REF.	PART NO.	DESCRIPTION	QTY.
1	64.1619	.Bracket, Wt. Transfer Selector	1
2	00.0314	.Decal, Weight Transfer	1
3	64.1612	.Bushing, Pivot Weight Transfer	1
4	95.10	.Washer, Flat 5/8 SAE	1
5	90.1036	.Bolt, 5/8-11 UNC x 4-1/2	1
6	03.0812	.Clevis Pin, 1/2 X 1-1/2	1
7	02.CP0506	.Cotter Pin, 5/32 X 3/4, Zinc	1
8	99.E0095	.Locknut, 5/8-11 Heavy Nylon	1
9	99.B0099	.Washer, Fender 1/2" x 2" OD ZP	2
10	99.0404	.Bolt, 1/4-20 x 1/2 BSCS	2
11	99.SF04	.Nut, SRF 1/4-20 USS	2
12	05.0002	.Washer, Fric. 2-1/4 X 13/32	1
13	40.0381	.Lever, Weight Transfer Select	1
14	95.06	.Washer, Flat 3/8 SAE	2
15	99.SF0614-1	.Bolt, SMF 3/8-16 X 1-3/4	1
16	99.A06N	.Locknut, Nylon 3/8-16	1
17	06.0044	.Cap, Plastic 1/8 x 1/2 x 7/8	1
18	70.4115*	.Kit, Weight Transfer 4500	1
19	41.0039	.Spring, Comp. 9/16 OD X 5/8	1

*Individual components of Weight Transfer Arm not available for service. Order kit # 70.4115 and follow the kit instructions to replace with pre-assembled components.

OPTIONS

ILLUSTRATED DRAWING

3 Point Hitch Frame (Kit #70.4160)

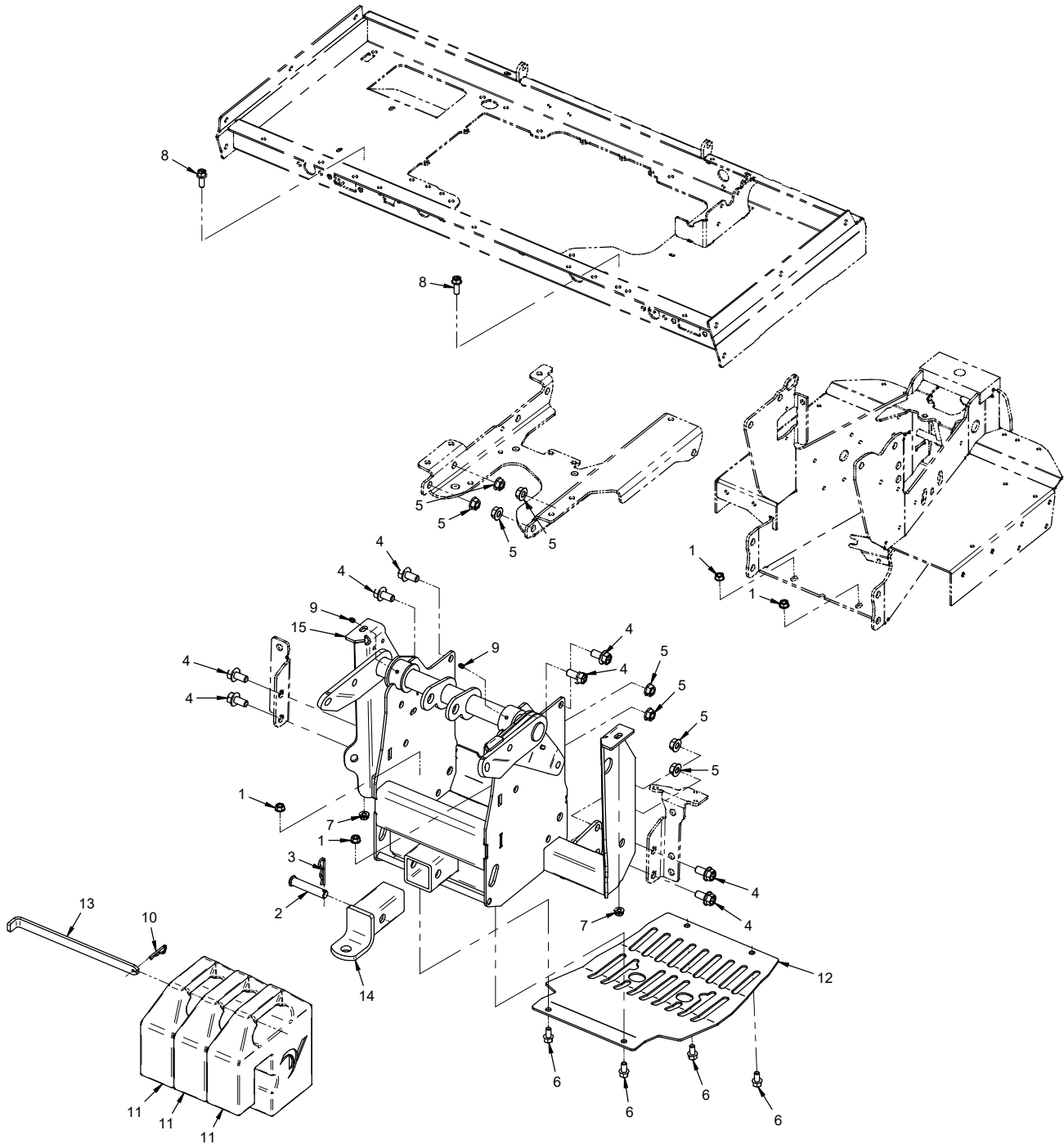

OPTIONS

3 Point Hitch Frame (Kit #70.4160)

REF.	PART NO.	DESCRIPTION	QTY.
1	99.SF06	Nut, SRF 3/8-16 USS	4
2	03.1024	Clevis Pin, 5/8 x 3 Oal ZP	1
3	02.HP0420	Hairpin, 1/8 x 2 9/16 ZP	1
4	99.SF0808-1	Bolt, SMF 1/2-13 x 1	8
5	99.SF08	Nut, SRF 1/2-13 USS	8
6	99.SF0606-1	Bolt, SMF 3/8-16 USS x 3/4	4
7	99.E0082	Nut, Locking Flange 3/8-16	2
8	99.SF0608-1	Bolt, SMF 3/8-16 x 1	2
9	29.GF0001	Grease Ftg, 1/4 SAE ST	2
10	02.HP0416	Hairpin, 1/8 X 2 ZP	1
11	47.0115-1	Weight, Suitcase - 42 LBS	3
12	64.1868	Plate, Rear Axle Skid w/3PT	1
13	64.1312	Pin, Weight Retainer	1
14	62.0968	Hitch, Rear	1
15	62.1365	Frame, Main 3-Point Hitch	1

OPTIONS

ILLUSTRATED DRAWING

3 Point Hitch Arms (Kit #70.4160)

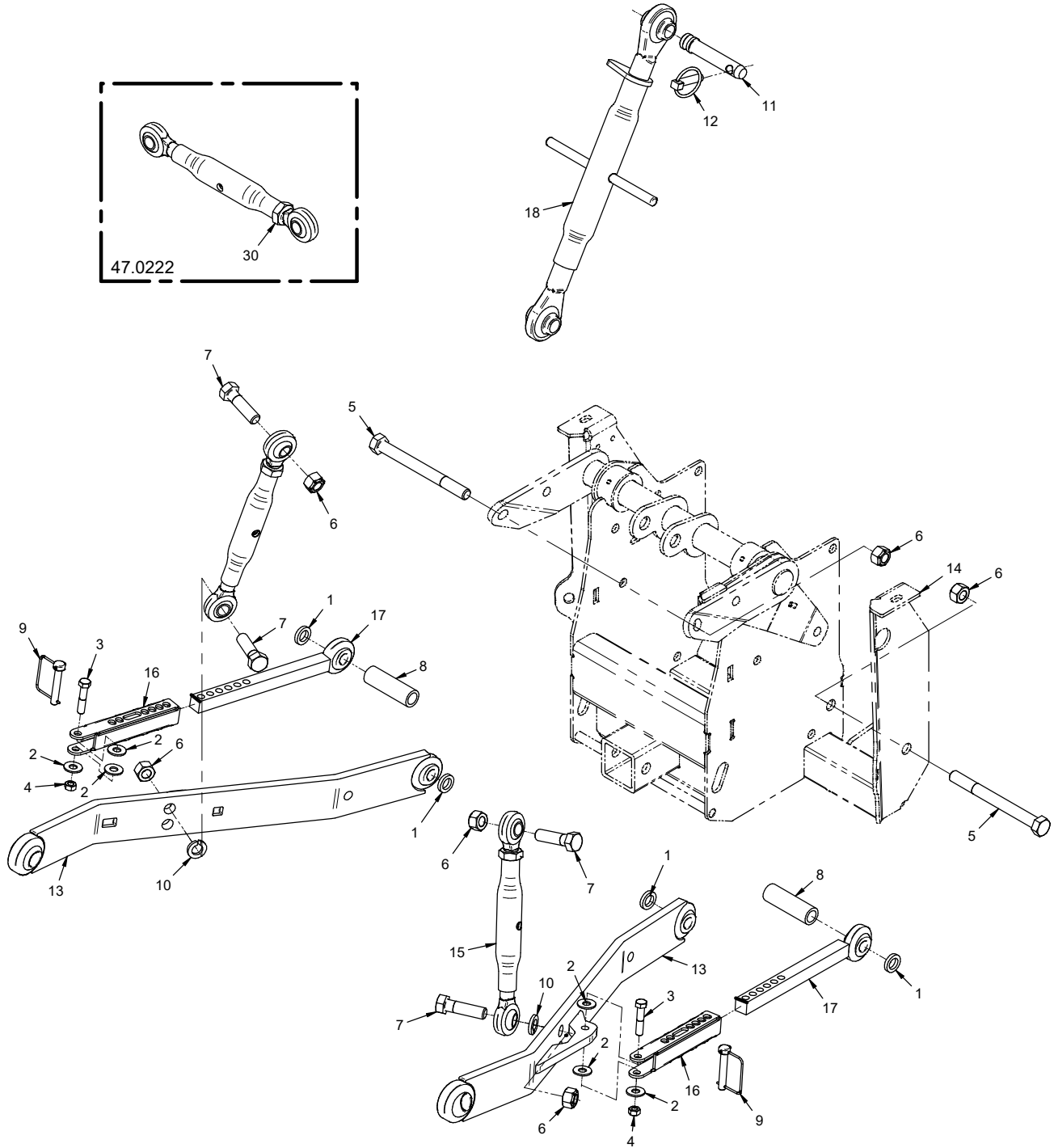

OPTIONS

3 Point Hitch Arms (Kit #70.4160)

REF.	PART NO.	DESCRIPTION	QTY.
1	99.B0061	Washer, 3/16 X 21/32 X 1 1/32	4
2	94.06	Washer, Flat 3/8 USS	6
3	90.0614	Bolt, 3/8-16 USS x 1-3/4	2
4	99.A06	Locknut, Stover 3/8-16 USS	2
5	90.1052	Bolt, 5/8-11 UNC x 6-1/2	2
6	99.A10	Locknut, Stover 5/8-11 USS	6
7	90.1018	Bolt, 5/8-11 USS x 2 1/4	4
8	64.1247	Bushing, Hitch Arm Spacer	2
9	03.0001	Pin, Safety Snap 3/8 X 1-3/4"	2
10	96.10	Washer, Lock 5/8	2
11	03.0004	Pin, Top Link Category 1	1
12	03.0005	Pin, Linch	1
13	40.0365	Arm, Universal Lift	2
14	62.1365	Frame, Main 3-Point Hitch	1
15	47.0222	Top Link, Cat. #0, Adjustable	2
16	42.0402	Link, Swaybar 3-Point Female	2
17	42.0403	Link, Swaybar 3-Pt Male	2
18	42.0406	Link, Top Cat #1 Complete	1
30	99.E0087	Nut, Jam 3/4-10 USS	1

OPTIONS

ILLUSTRATED DRAWING

3 Point Hitch Hydraulics (Kit #70.4160)

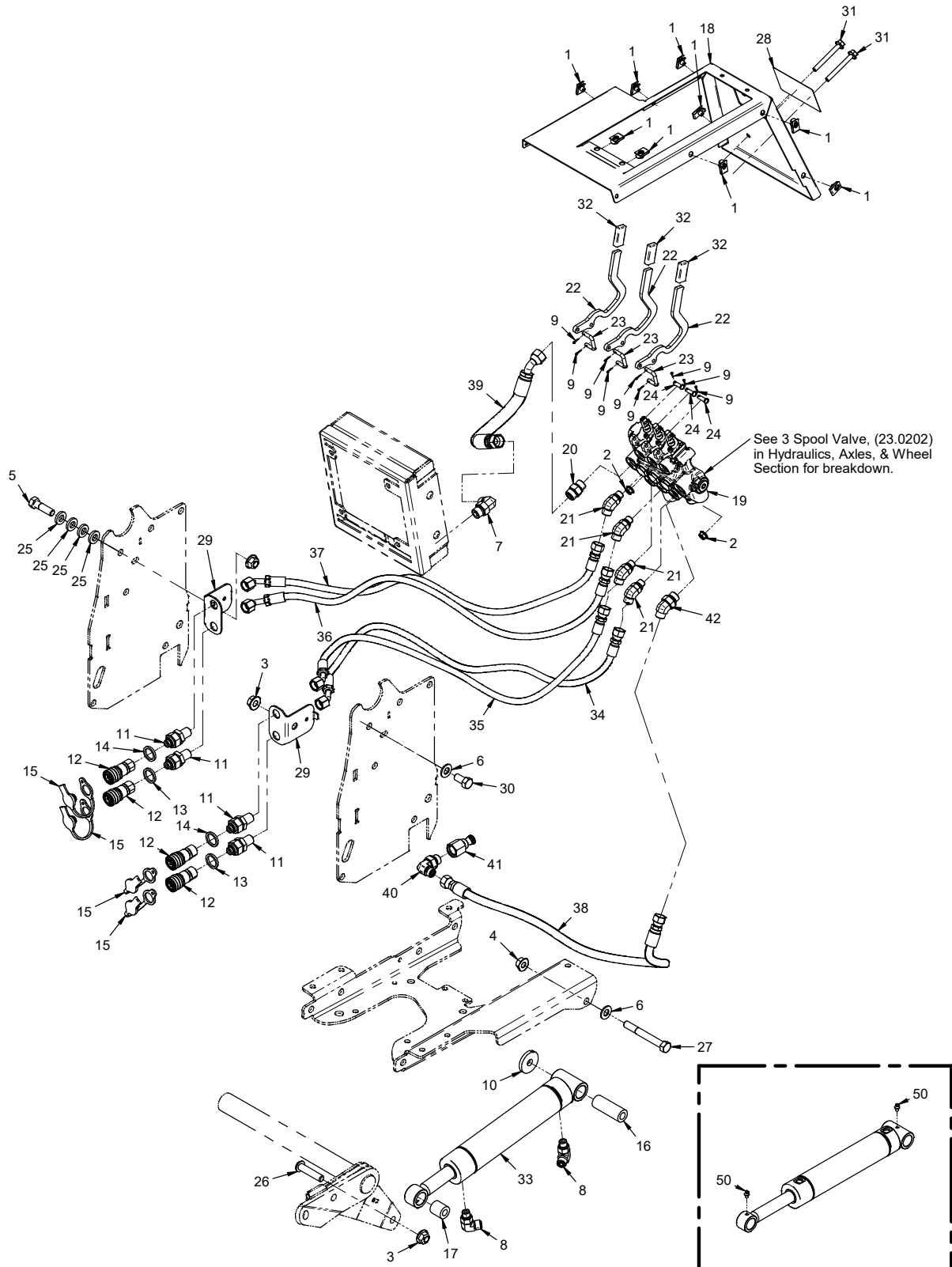

OPTIONS

3 Point Hitch Hydraulics (Kit #70.4160)

REF.	PART NO.	DESCRIPTION	QTY.
1	99.E0046	.Nut, "U" 1/4-20 Extruded	9
2	99.SF05	.Nut, SRF 5/16-18 USS	2
3	99.E0103	.Nut, Locking Flange 1/2-13	3
4	99.SF08	.Nut, SRF 1/2-13 USS	1
5	90.0814	.Bolt, 1/2-13 USS x 1-3/4	1
6	95.08	.Washer, Flat 1/2 SAE	2
7	25.FF6801-08-08	.Fitting, 90 Elbow 8MFF x 8MB	1
8	25.FF6801-06-06	.Fitting, 90 Elbow - 6MFF X 6MB	2
9	02.CP0204	.Cotter Pin, 1/16 X 1/2, Zinc	9
10	99.B0064	.Washer, 1/4 x 1.75 x .531 Hole	1
11	25.FF2764-06-06-LN	.Fitting, Bulkhead Straight 3/8	4
12	23.0197	.Coupler, Hyd Quick Female 1/4 ORB	4
13	05.0190	.Washer, .905 ID x 1.170 x .140 Red	2
14	05.0191	.Washer, .905 ID x 1.170 x .140 Yellow	2
15	23.0126	.Plug, Dust for 23.0106	4
16	64.1722	.Bushing, Steel .563 X 1.000	1
17	64.0749	.Bushing, Steel 0.516 x 1.000	1
18	KN-1243	.Cover, Hydraulic Cooler Top Front	1
19	23.0202	.Valve, 3-Spool	1
20	25.FF6400-08-08	.Fitting, Connector 8MFF x 8MB	1
21	25.FF6802-06-08	.Fitting, 45 Elbow -06MF x -08MB	1
22	25.FF6802-06-06	.Fitting, 45 Elbow - 6Mff X 6Mb.	4
23	KN-1200	.Lever, KN 3PT Hyd Handle	3
24	KN-3010	.Link, Valve Handle "C"	3
25	03.0406	.Clevis Pin, 1/4 X 3/4	3
26	99.B0092	.Washer, 17/32ID X 1"OD X .165	4
27	99.0818	.Bolt, 1/2-13 x 2-1/4 BSCS	1
28	90.0832	.Bolt, 1/2-13 USS x 4	1
29	00.0686	.Decal, 3Pt Hitch	1
30	KN-1195	.Bracket, Hyd. Quick Coupler	2
31	90.0808	.Bolt, 1/2-13 USS x 1	1
32	99.SF0522-1	.Bolt, SMF 5/16-18 x 2-3/4	2
33	06.0058	.Cap, Plastic 1/4 x 5/8 x 1-1/2	3
34	23.0128	.Cylinder, 2" X 8" Lift	1
35	20.0399	.Hose, 1/4x33.00 SAE 100R17AR	1
36	20.0399	.Hose, 1/4x33.00 SAE 100R17AR	1
37	20.0399	.Hose, 1/4x33.00 SAE 100R17AR	1
38	20.0399	.Hose, 1/4x33.00 SAE 100R17AR	1
39	20.0393	.Hose, 3/8x33.00 SAE 100R17AR	1
40	22.0083	.Hose, 1/2x13.75 ASTM D380 / ASTM D6751	1
41	24.0021	.Fitting, Special Power Beyond - SAE08	1
42	25.FF6802-06-08	.Fitting, 45 Elbow -06MF x -08MB	1
50	29.GF0013	.Grease FTG, Adpt 1/4-28	2

OPTIONS

ILLUSTRATED DRAWING

3 Point Hitch Hydraulic Diagram (Kit #70.4160)

3-Point Lift Cylinder

3 Spool Valve

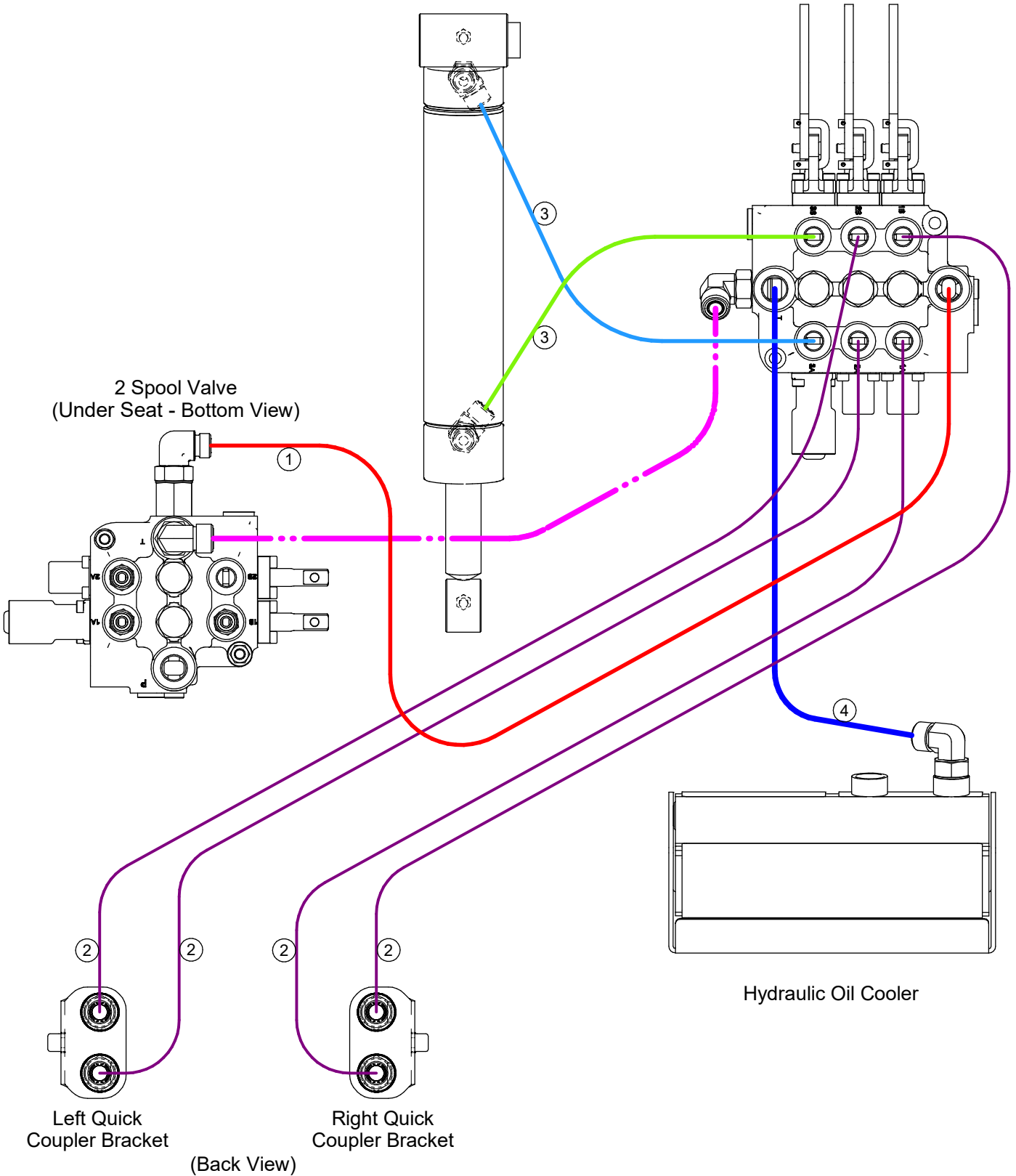

OPTIONS

3 Point Hitch Hydraulic Diagram (Kit #70.4160)

REF.	PART NO.	DESCRIPTION	QTY.
1	20.0393	Hose, 3/8x33.00 SAE 100R17AR.	1
2	20.0399	Hose, 1/4x33.00 SAE 100R17AR.	4
3	20.0400	Hose, 1/4x23.00 SAE 100R17AR.	2
4	22.0083	Hose, 1/2x13.75 ASTM D380 / ASTM D6751.	1

OPTIONS

ILLUSTRATED DRAWING

Rear Hydraulic Valve (Kit# 70.4165)

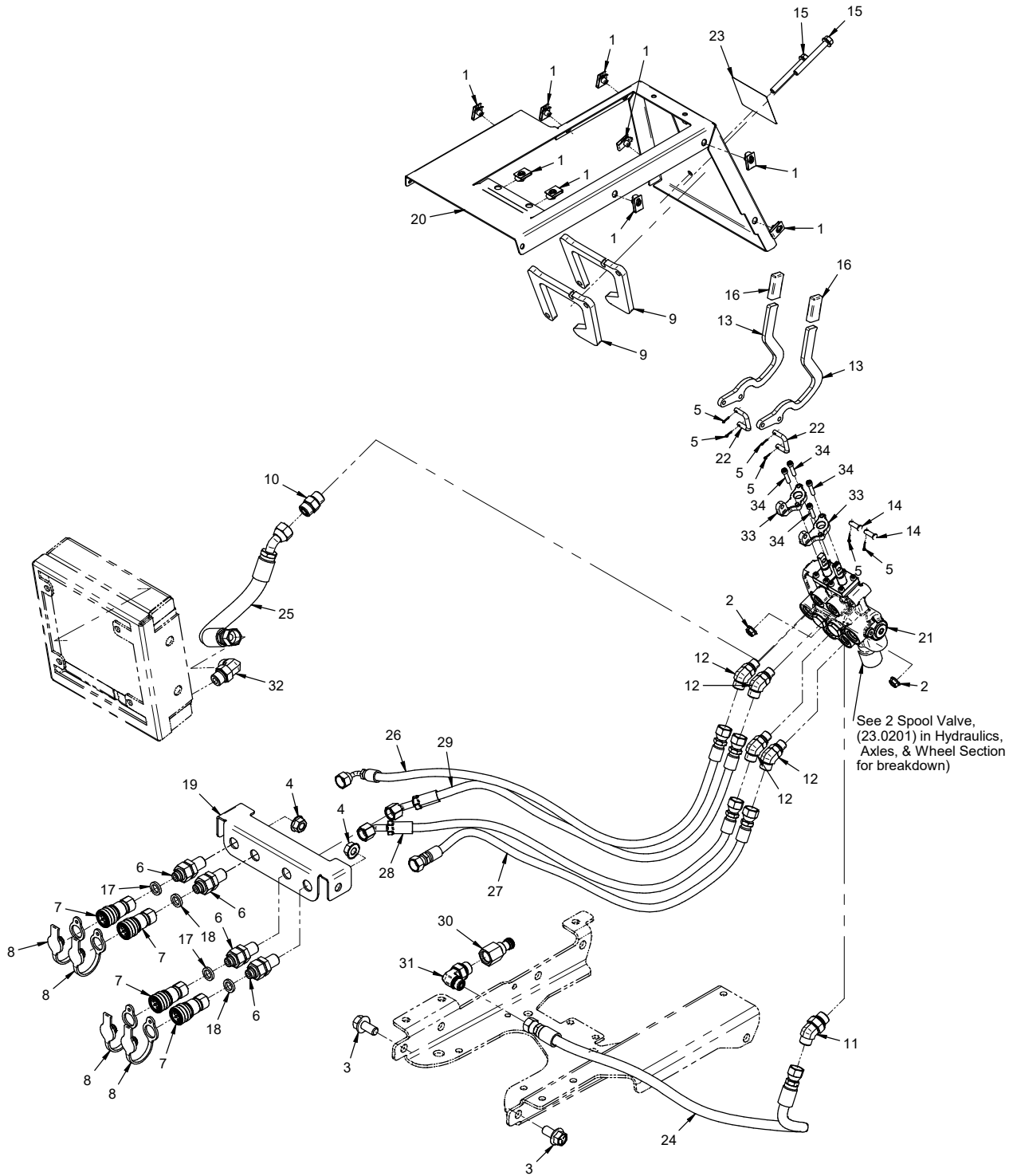

OPTIONS

Rear Hydraulic Valve (Kit# 70.4165)

REF.	PART NO.	DESCRIPTION	QTY.
1	99.E0046	.Nut, "U" 1/4-20 Extruded	9
2	99.SF05	.Nut, SRF 5/16-18 USS	2
3	99.SF0808-1	.Bolt, SMF 1/2-13 x 1	2
4	99.SF08	.Nut, SRF 1/2-13 USS	2
5	02.CP0204	.Cotter Pin, 1/16 X 1/2, Zinc	6
6	25.FF2764-06-06-LN	.Fitting, Bulkhead Straight 3/8	4
7	23.0197	.Coupler, Hyd Quick Female 1/4 ORB	4
8	23.0126	.Plug, Dust for 23.0106	4
9	KN-1202	.Plate, Valve Standoff	2
10	25.FF6400-08-08	.Fitting, Connector 8MFF x 8MB	1
11	25.FF6802-06-08	.Fitting, 45 Elbow -06MFF x -08MB	1
12	25.FF6802-06-06	.Fitting, 45 Elbow - 6Mff X 6Mb	4
13	KN-1200	.Lever, KN 3PT Hyd Handle	2
14	03.0406	.Clevis Pin, 1/4 X 3/4	2
15	99.SF0522-1	.Bolt, SMF 5/16-18 x 2-3/4	2
16	06.0058	.Cap, Plastic 1/4 x 5/8 x 1-1/2	2
17	05.0117	.Washer, .544 ID x .817 x .14 Yel	2
18	05.0116	.Washer, .544 ID x .817 x .14 Red	2
19	KN-1067	.Bracket, Hyd Coupler Rear 4	1
20	KN-1295	.Cover, Hydraulic Cooler Top Front	1
21	23.0201	.Valve, 2-Spool w/ Detent (See Hydraulics, Axles, & Wheels Section for breakdown)	1
22	23.0203	.Link, Valve Handle "C"	2
23	00.0669	.Decal, Rear Hyd Valve 4520	1
24	20.0393	.Hose, 3/8x33.00 SAE 100R17AR	1
25	22.0083	.Hose, 1/2x13.75 ASTM D380 / ASTM D6751	1
26	20.0415	.Hose, 1/4x28.00 SAE 100R17AR	1
27	20.0416	.Hose, 1/4x27.00 SAE 100R17AR	1
28	20.0399	.Hose, 1/4x33.00 SAE 100R17AR	1
29	20.0399	.Hose, 1/4x33.00 SAE 100R17AR	1
30	24.0021	.Fitting, Special Power Beyond - SAE08	1
31	25.FF6801-06-08	.Fitting, 90 Elbow 06MFF x 08MB	1
32	25.FF6801-08-08	.Fitting, 90 Elbow 8MFF x 8MB	1
33	23.0211	.BRACKET, HANDLE	2
34	99.M0074	.BOLT, M5X25MM SHCS	4

OPTIONS

ILLUSTRATED DRAWING

Rear Hydraulic Valve Diagram (Kit# 70.4165)

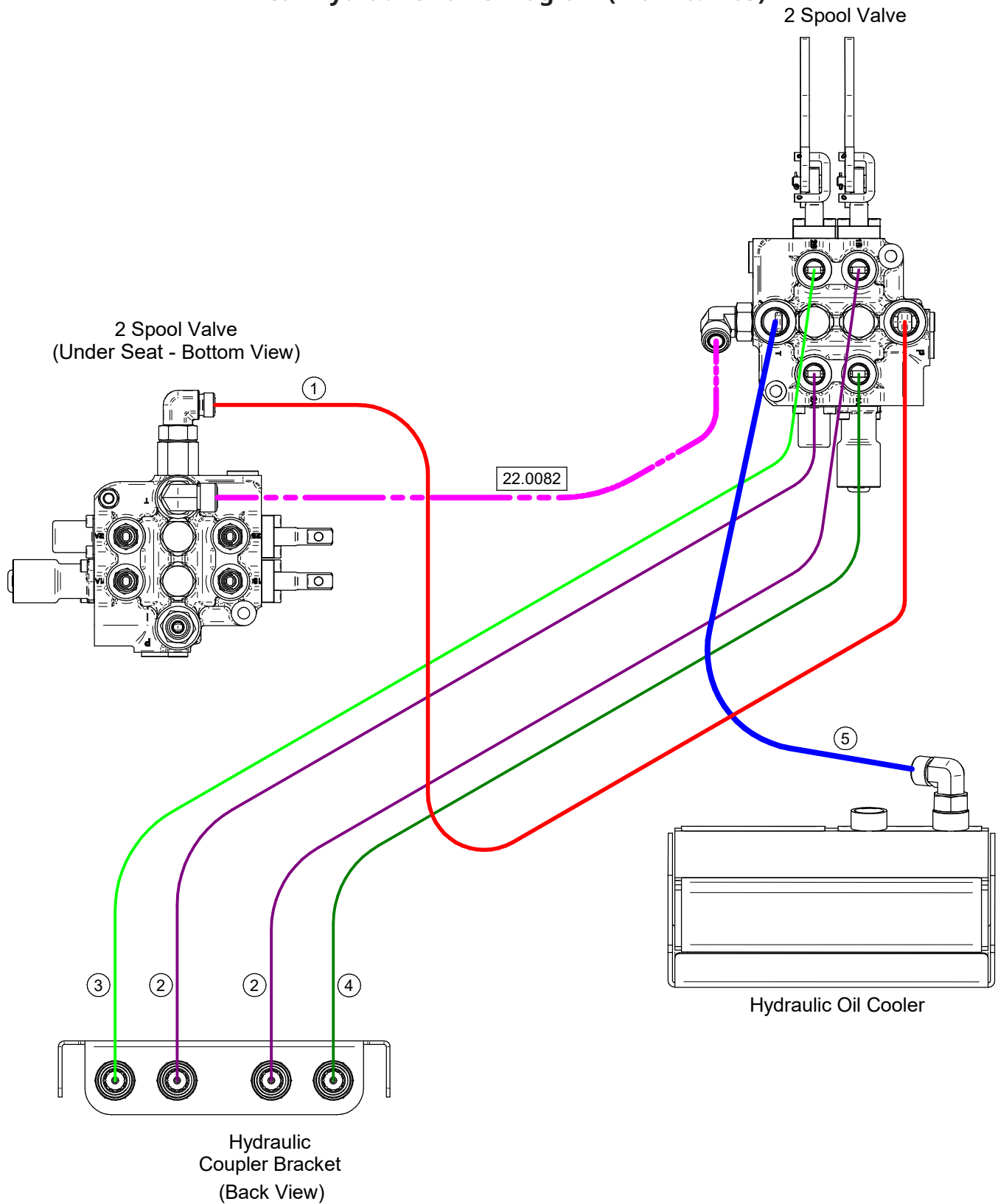

OPTIONS

Rear Hydraulic Valve Diagram (Kit# 70.4165)

REF.	PART NO.	DESCRIPTION	QTY.
1	20.0393	Hose, 3/8x33.00 SAE 100R17AR.	1
2	20.0399	Hose, 1/4x33.00 SAE 100R17AR.	2
3	20.0415	Hose, 1/4x28.00 SAE 100R17AR.	1
4	20.0416	Hose, 1/4x27.00 SAE 100R17AR.	1
5	22.0083	Hose, 1/2x13.75 ASTM D380 / ASTM D6751.	1

OPTIONS

ILLUSTRATED DRAWING 70.4098 Wheel Extension Kit

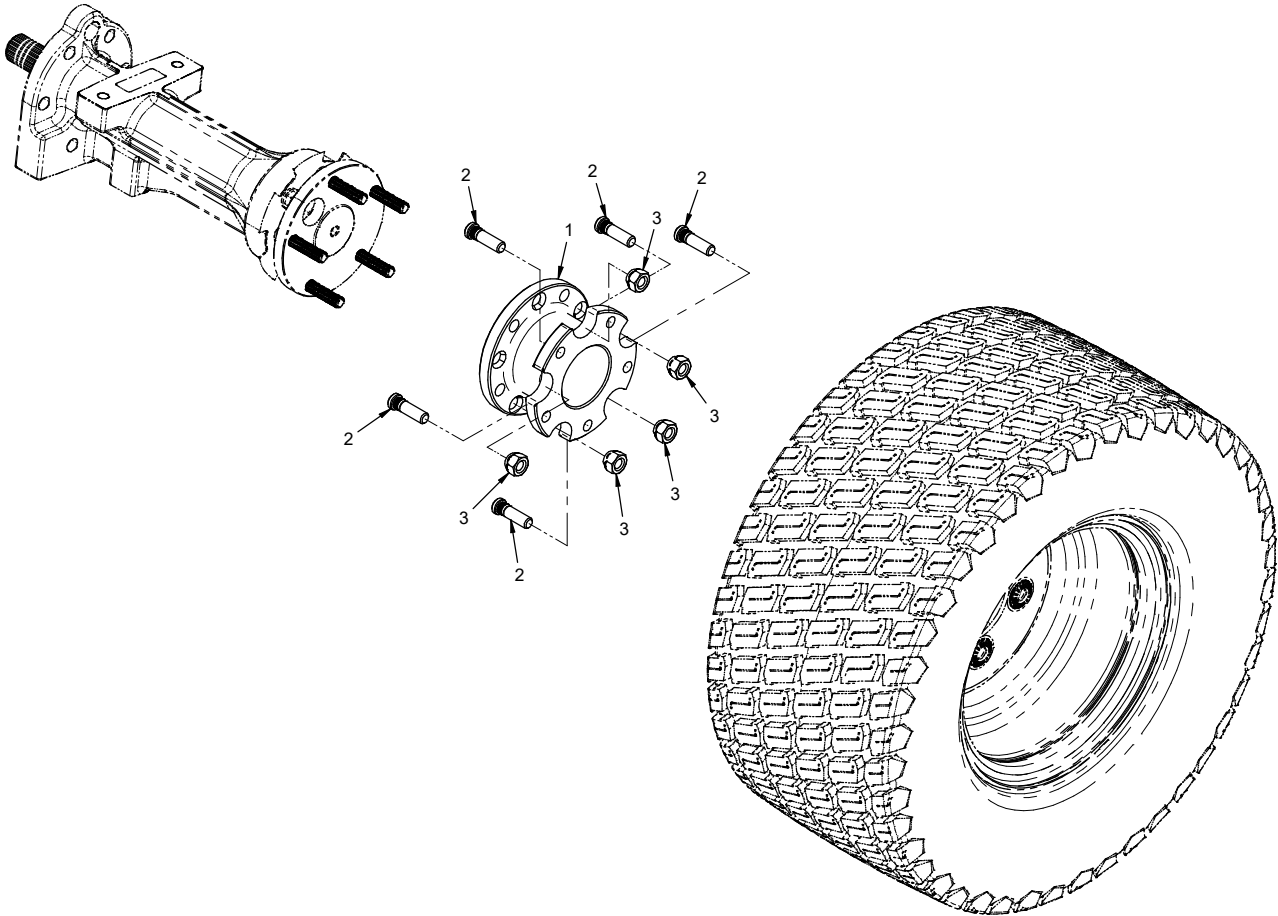

OPTIONS

70.4098 Wheel Extension Kit

REF.	PART NO.	DESCRIPTION	QTY.
1	53.0144	Hub, 3" Wheel Extension	4
2	99.K0120	Bolt, 7/16-20 x 1-1/2 Whl Stud.	20
3	99.E0044	Nut, Lug 7/16-20 SAE	20

OPTIONS

ILLUSTRATED DRAWING

70.4163 Foot Control Kit

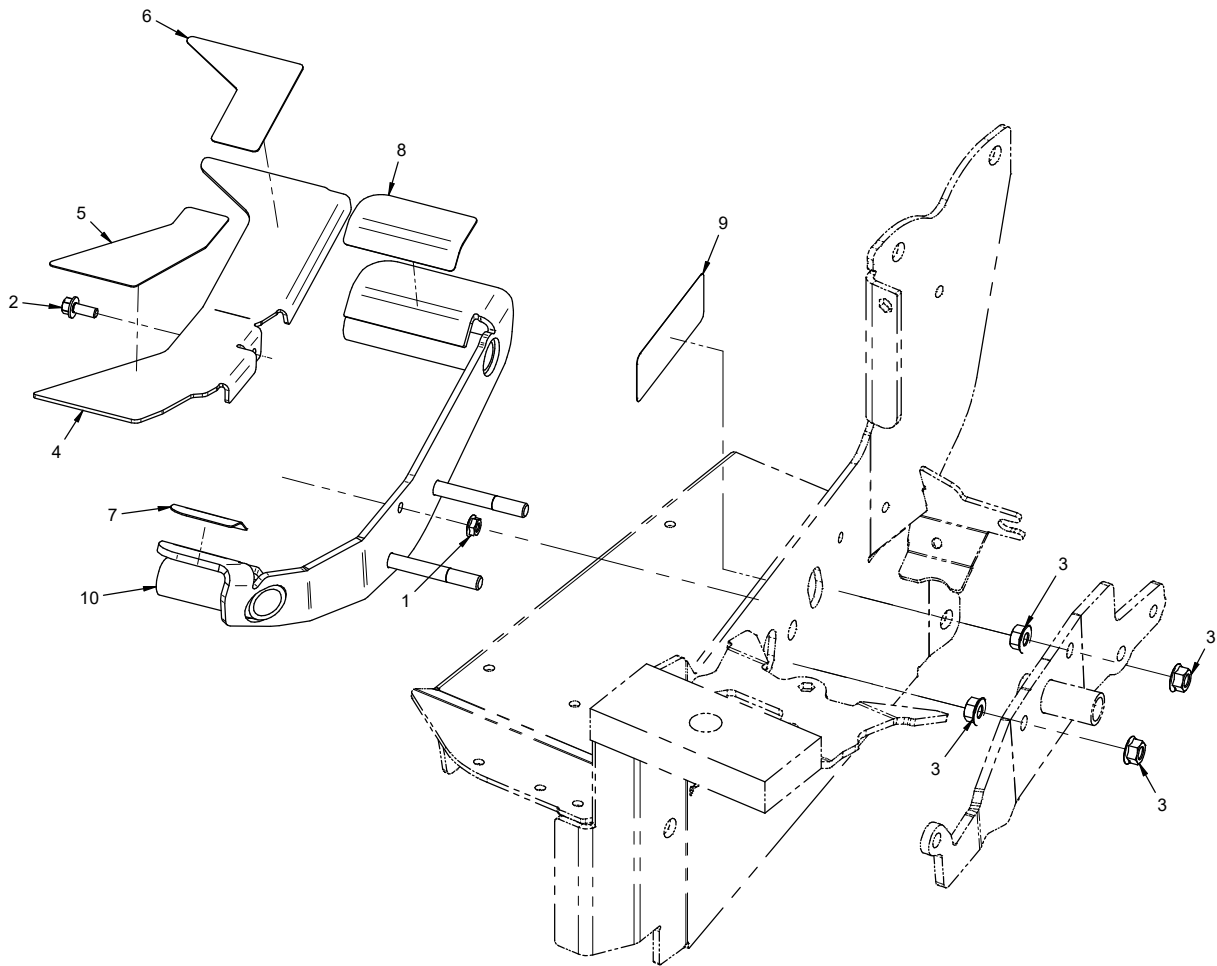

OPTIONS

70.4163 Foot Control Kit

REF.	PART NO.	DESCRIPTION	QTY.
1	99.SF04	Nut, SRF 1/4-20 USS	1
2	99.SF0405-1	Bolt, SMF 1/4-20 X 5/8	1
3	99.SF06	Nut, SRF 3/8-16 USS	4
4	KN-1292	Plate, Foot Center 4520	1
5	KN-1327	Flex Tread, Foot Plate Front	1
6	KN-1328	Flex Tread, Foot Plate Rear	1
7	KN-1329	Flex Tread, Foot Pedal Front	1
8	KN-1330	Flex Tread, Foot Pedal Rear	1
9	00.0338	Decal, Foot Control	1
10	KN-6030	Pedal, Foot 4520	1

OPTIONS

ILLUSTRATED DRAWING 70.4108 Raised Platform Kit

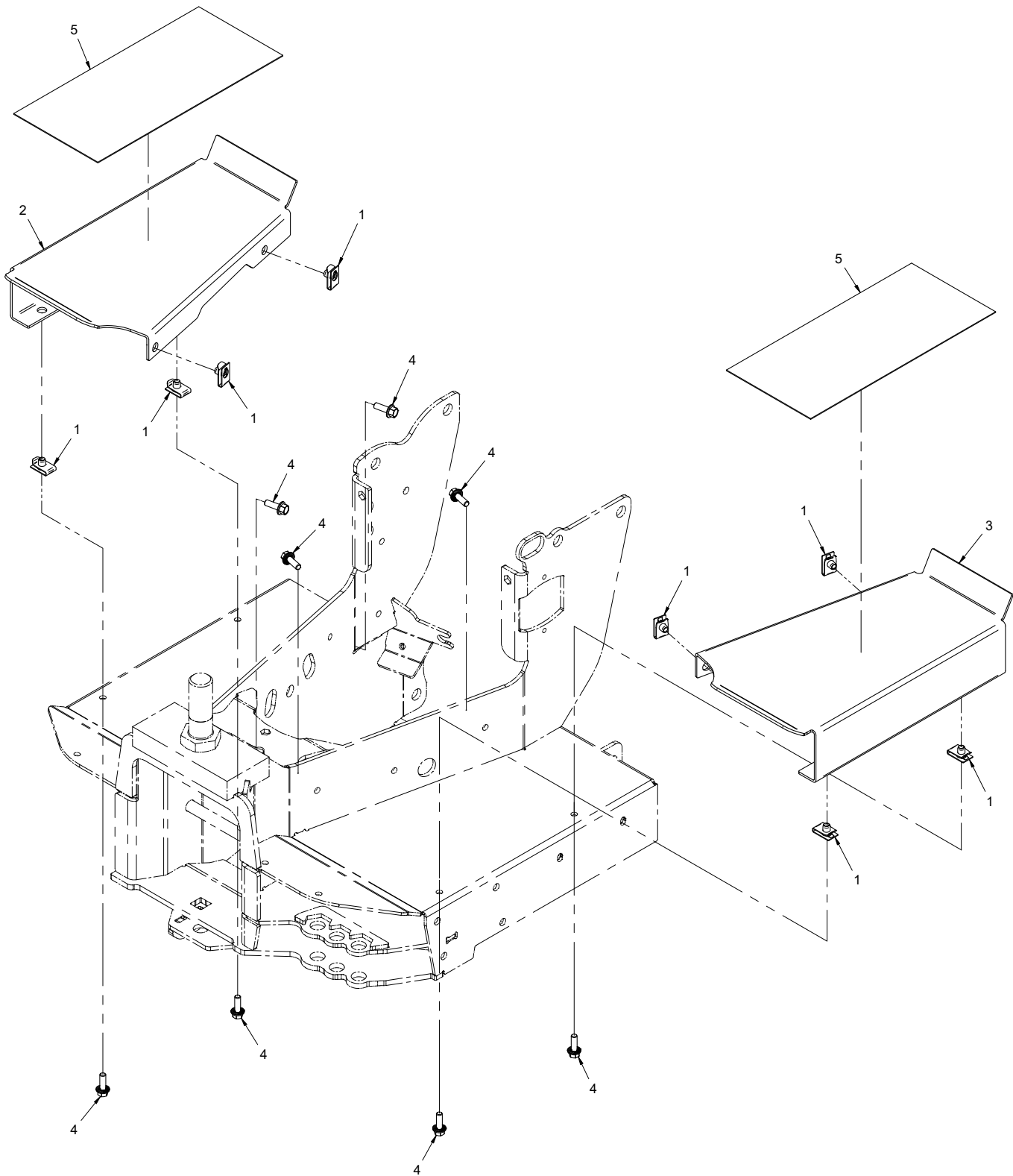

OPTIONS

70.4108 Raised Platform Kit

REF.	PART NO.	DESCRIPTION	QTY.
1	99.E0046	Nut, "U" 1/4-20 Extruded	8
2	62.1384	Frame, Raised Platform RH	1
3	62.1388	Frame, Raised Platform LH	1
4	99.SF0406	Bolt, SRF 1/4-20 X 3/4	8
5	56.0055-11IN	Flex Tread, 5" Black Coarse x 11"	2

OPTIONS

ILLUSTRATED DRAWING

70.4105 12 Volt Rear Plug Kit (Serial # 01001-02172)

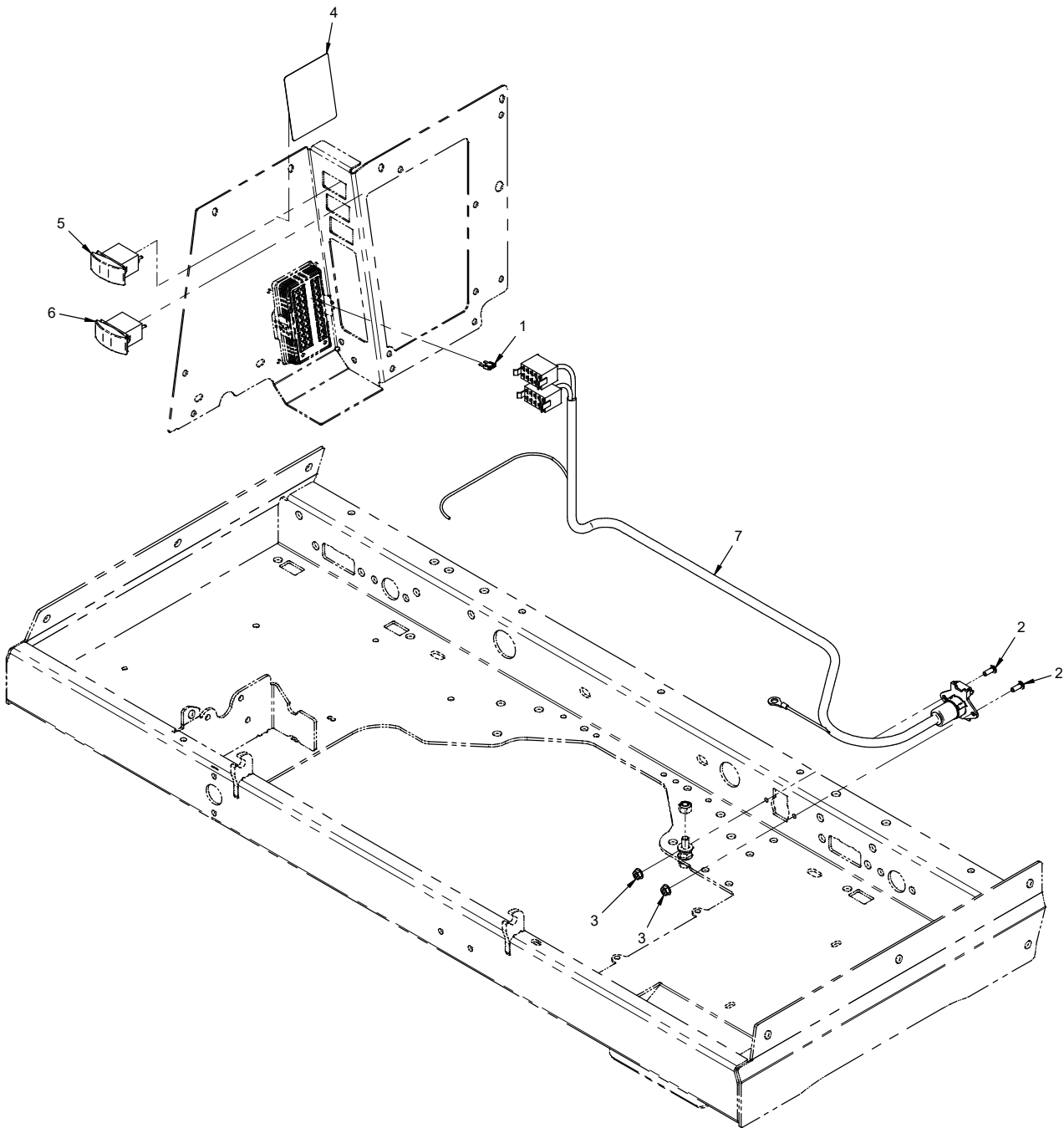

OPTIONS

70.4105 12 Volt Rear Plug Kit (Serial # 01001-02172)

REF.	PART NO.	DESCRIPTION	QTY.
1	30.0335	.Fuse, 20 Amp Mini Yellow	1
2	99.K0062	.Machine Screw, #10-32 X 1/2	2
3	99.E0035	.Nut, SF #10-32	2
4	00.0662	.Decal, 12V Rear	1
5	31.0053	.Switch, Rocker On/Off	1
6	31.0056	.Switch, Rocker (On)/Off/(On)	1
7	32.0113	.Harness, Wire 12V Rear	1

OPTIONS

ILLUSTRATED DRAWING

70.4179 12 Volt Rear Plug Kit (Serial # 02173-)

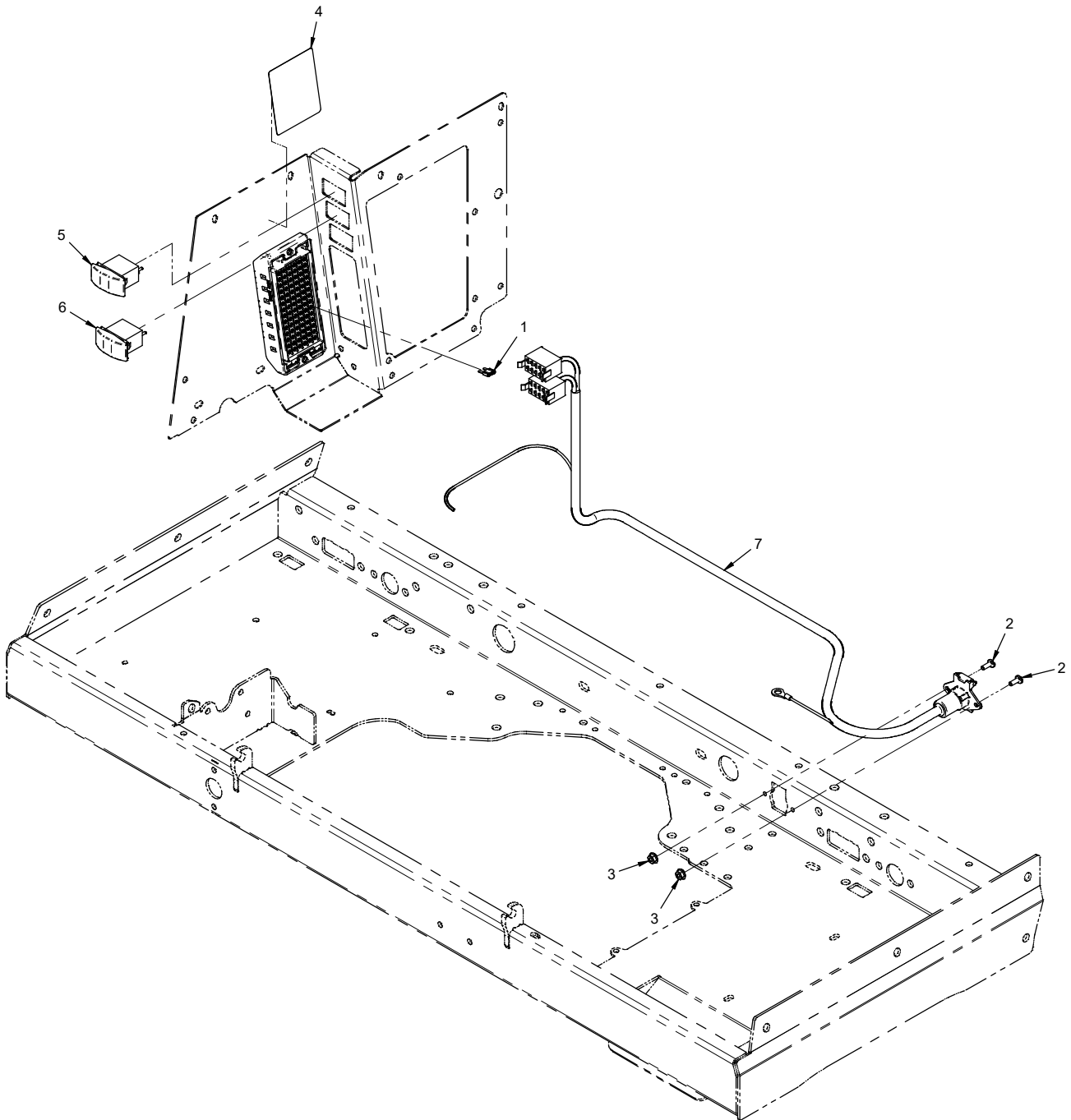

OPTIONS

70.4179 12 Volt Rear Plug Kit (Serial # 02173-)

REF.	PART NO.	DESCRIPTION	QTY.
1	30.0335	Fuse, 20 Amp Mini Yellow	1
2	99.K0062	Machine Screw, #10-32 X 1/2	2
3	99.E0035	Nut, SF #10-32	2
4	00.0662	Decal, 12V Rear	1
5	31.0053	Switch, Rocker On/Off	1
6	31.0056	Switch, Rocker (On)/Off/(On)	1
7	32.0242	Harness, Wire 12V Rear	1

OPTIONS

ILLUSTRATED DRAWING

70.4120 Horn Kit

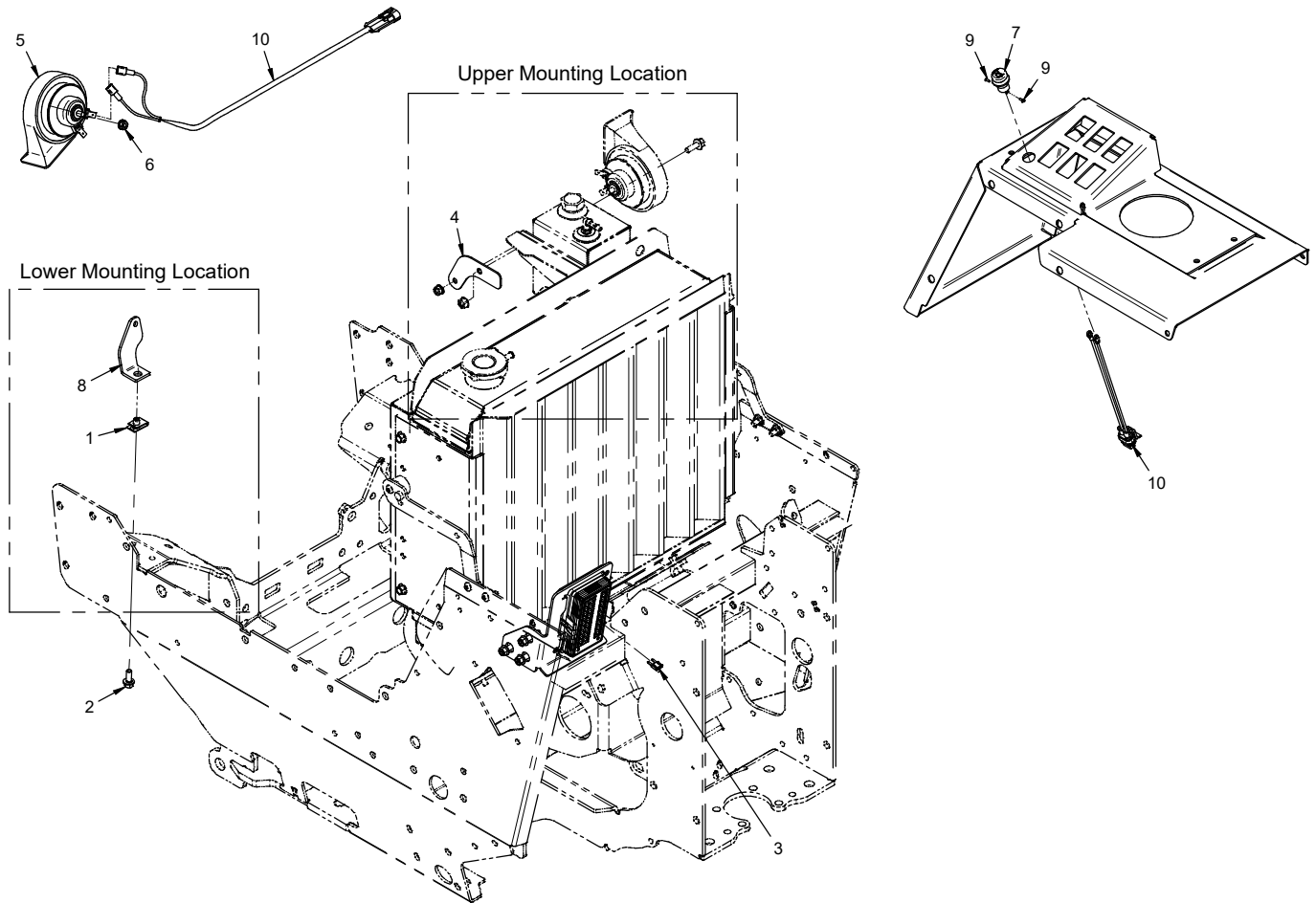

OPTIONS

70.4120 Horn Kit

REF.	PART NO.	DESCRIPTION	QTY.
1	99.E0046	Nut, "U" 1/4-20 Extruded	1
2	99.SF0405-1	Bolt, SMF 1/4-20 X 5/8.	1
3	30.0333	Fuse, 10 Amp Mini Red	1
4	KN-1502	Bracket, Horn	1
5	33.0019	Horn, Low Tone	1
6	99.M0029	Nut, M6 x 1.0 W/Lock Washer	1
7	31.0057	Switch, Horn	1
8	64.1711	Bracket, Horn	1
9	99.K0125	Machine Screw, #2-56 x 3/16	2
10	32.0115	Harness, Wire Horn	1

OPTIONS

ILLUSTRATED DRAWING

70.4102 Kubota Engine Heater Kit

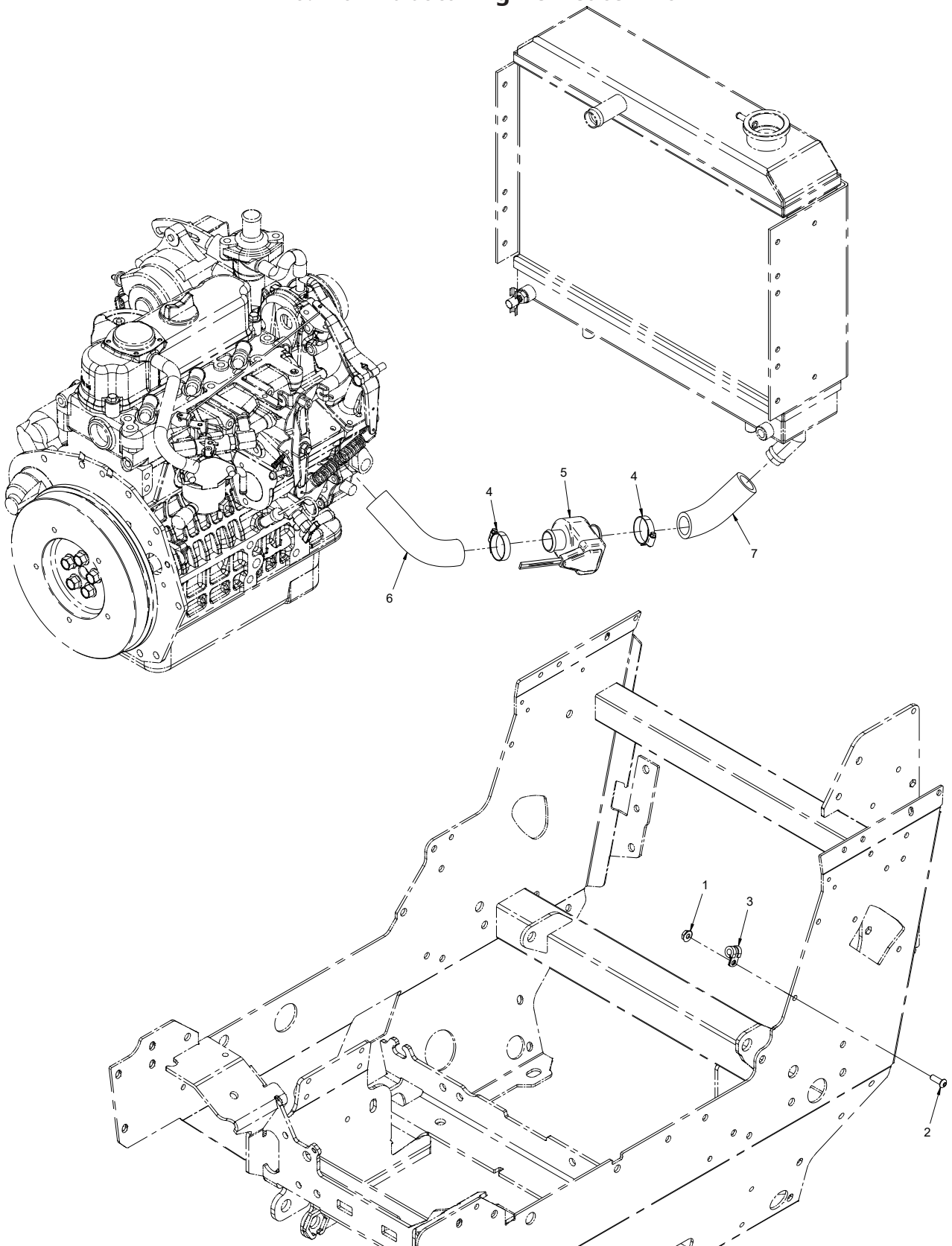

OPTIONS

70.4102 Kubota Engine Heater Kit

REF.	PART NO.	DESCRIPTION	QTY.
1	99.SF04	Nut, SRF 1/4-20 USS	1
2	99.0406	Bolt, 1/4-20 x 3/4 BSCS	1
3	11.0058	Clamp, Cushioned 3/8" Round	1
4	11.0052	Clamp, Hose SS 13/16 x 1-1/2	2
5	13.0303	Heater, Radiator Hose	1
6	13.0263-1	Hose, Heater Engine Side	1
7	13.0263-2	Hose, Heater Radiator Side	1

OPTIONS

ILLUSTRATED DRAWING 70.4140 Slope Indicator Kit

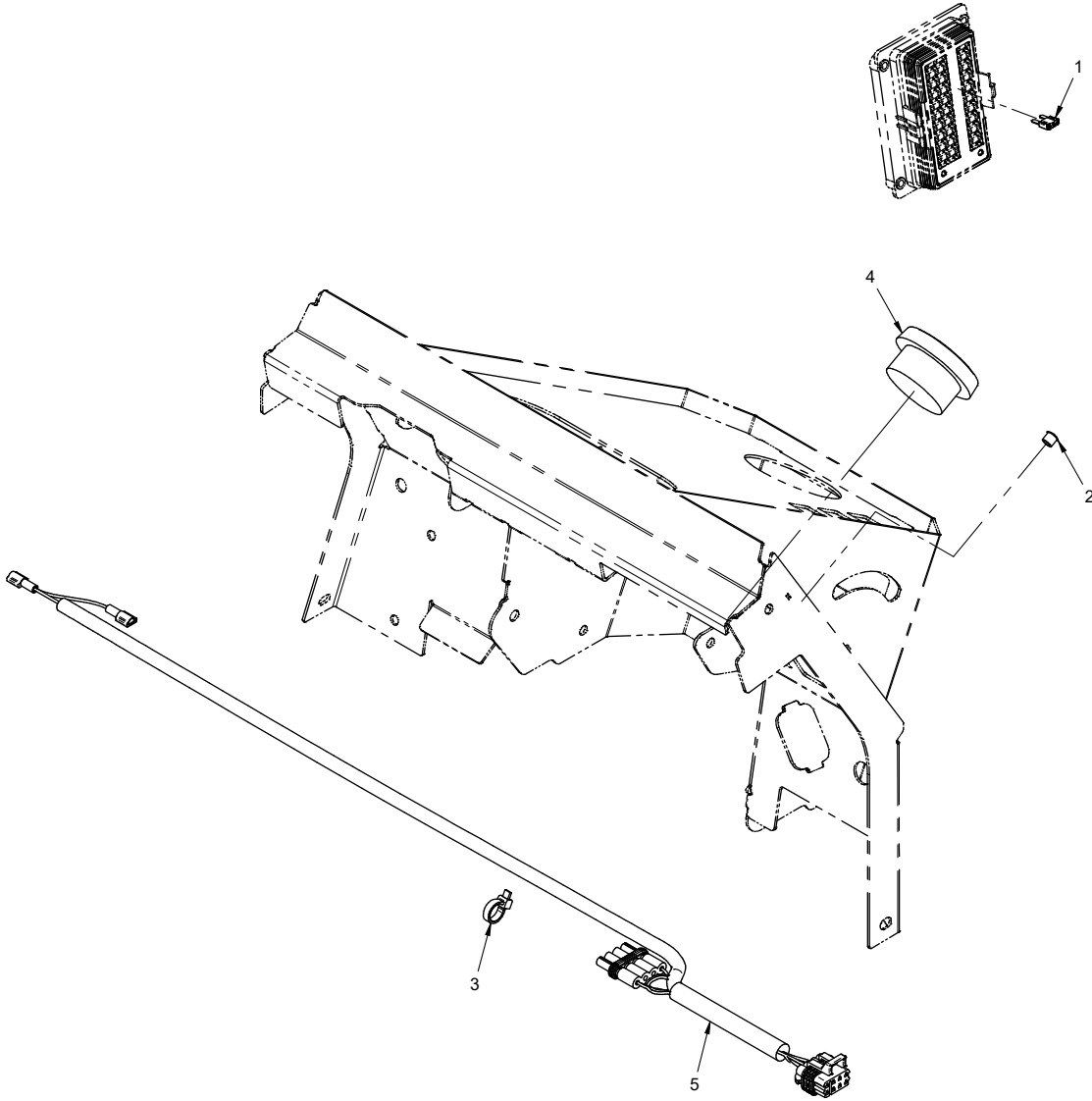

OPTIONS

70.4140 Slope Indicator Kit

REF.	PART NO.	DESCRIPTION	QTY.
1	30.0332	Fuse, 5 Amp Mini Tan	1
2	05.0147	Plug, 5/16" Hole, Nylon Black	1
3	30.0037	Tyton Tie, #50 .18 x 8 Black	4
4	35.0145	Gauge, Slope Indicator	1
5	32.0166	Harness, Wire Slope Indicator	1

OPTIONS

ILLUSTRATED DRAWING 70.4144 Rear Weight Bar Kit

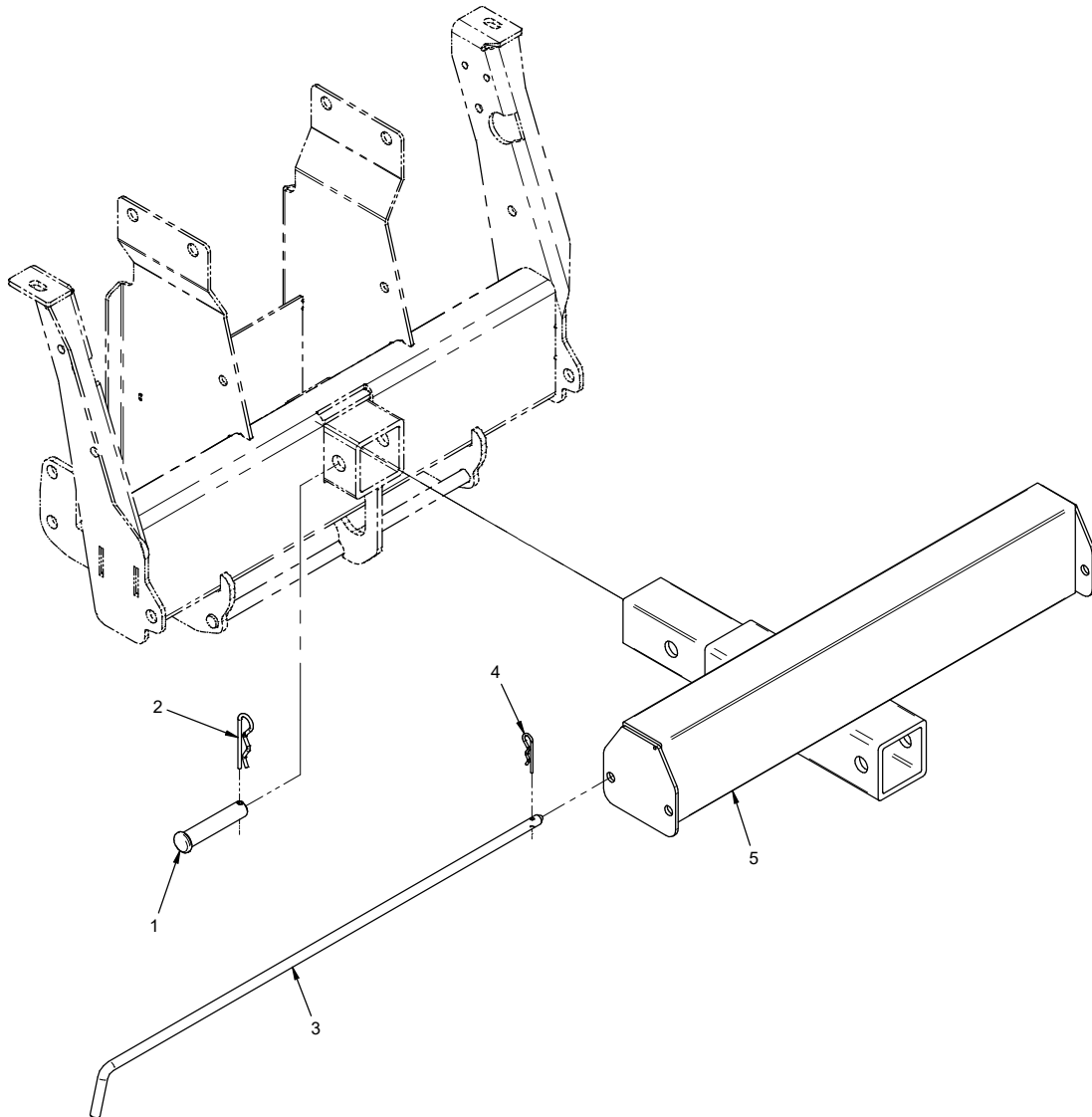

OPTIONS

70.4144 Rear Weight Bar Kit

REF.	PART NO.	DESCRIPTION	QTY.
1	03.1024	Clevis Pin, 5/8 X 3 OAL	1
2	02.HP0420	Hairpin, 1/8 X 2 1/2	1
3	64.1912	Pin, Weight Secure 22.5" Usable	1
4	02.HP0313	Hairpin, 3/32 X 1-5/8	1
5	62.1454	Frame, Rear Weight Bar	1

OPTIONS

ILLUSTRATED DRAWING

Dual Wheels

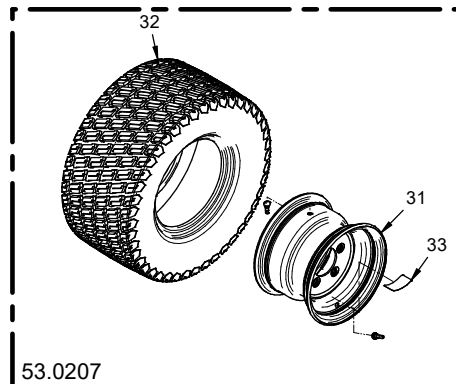
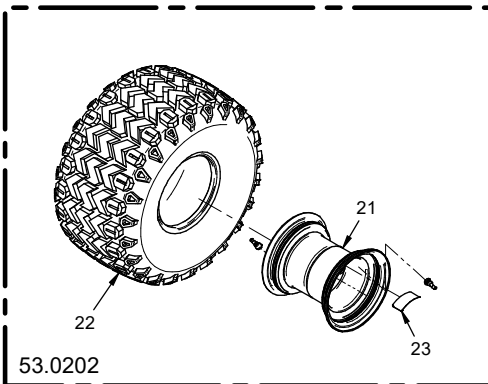
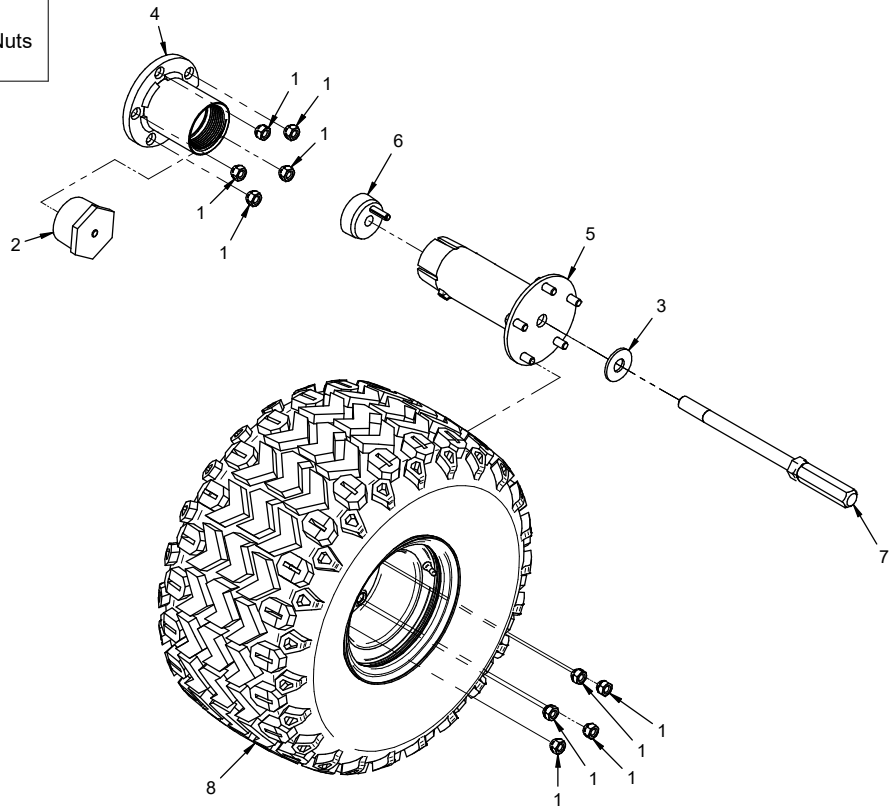
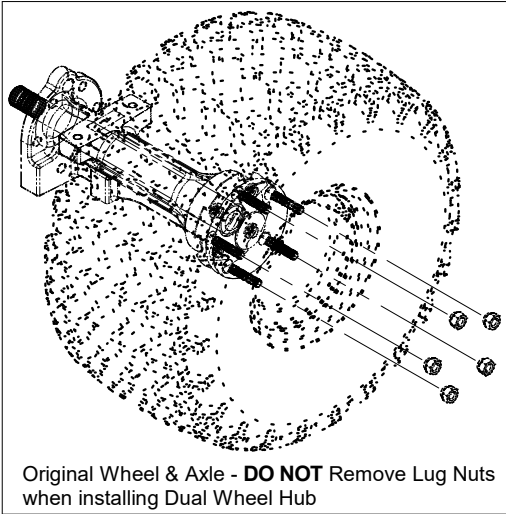

OPTIONS

Dual Wheels

REF.	PART NO.	DESCRIPTION	QTY.
1	99.E0044	Nut, Lug 7/16-20 SAE	40
2	05.0195	Plug, 2-1/2 Npt M, Black ABS	4
3	94.12	Washer, Flat 3/4 USS	4
4	50.0190	Increased Stud Hole Flare From .65 to .725	4
5	50.0061	Change Slot Width in 61.36004	4
6	50.0063	Cone, 3/4" Drawcone Duals	4
7	64.0672	Bolt, 3/4" Drawbolt Duals	4
8	53.0202	Wheel, Asm 22 X 12 X 8 Field	4
8	53.0207	Wheel, Asm 22 X 11 X 10 X 5B Turf	4
21	53.0203	Rim, 8 X 8.5, 5 On 4.5 BC	1
22	53.0089	Tire, Field 22 X 12 X 8-No Rim	1
23	00.0645	Decal, Hub Side	1
31	53.0208	Rim, 10 X 7 - 5 On 4.5 BC	1
32	53.0112	Tire, Turfmastr 22X11X10 No Rim	1
33	00.0645	Decal, Hub Side	1

OPTIONS

ILLUSTRATED DRAWING

70.4169 Canopy Kit

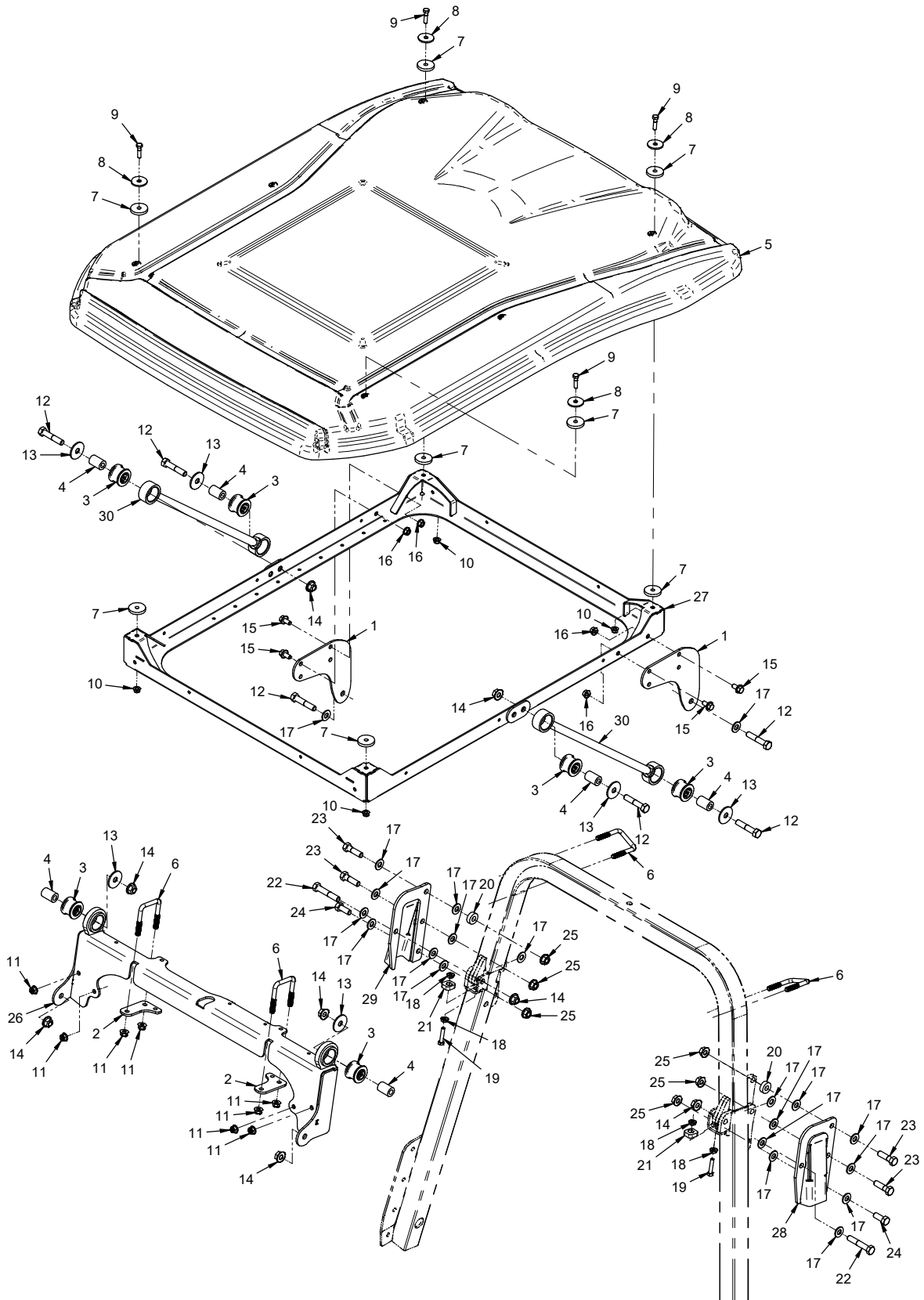

OPTIONS

70.4169 Canopy Kit

REF.	PART NO.	DESCRIPTION	QTY.
1	KN-1222	.Mount, Canopy Frame	2
2	KN-1225	.Plate, Rollbar Mount	2
3	85.B0113	.Bushing, Link Rod	6
4	64.2034	.Spacer, Link Rod	6
5	44.0363	.Roof, Cab	1
6	11.0053	.U-Bolt, 3/8-16 2-1/16" ID SQ Bend	4
7	05.0085	.Washer, Neoprene	8
8	99.B0076	.Washer, .130T x .395ID x 1.5OD	4
9	90.0510	.Bolt, 5/16-18 USS x 1-1/4	4
10	99.E0102	.Nut, Locking Flange 5/16-18	4
11	99.E0136	.Nut, Nylon Locking Flange 3/8-16	8
12	90.0820	.Bolt, 1/2-13 USS x 2-1/2	6
13	99.B0141	.Washer, Fender 1/2 x 1-3/4 OD	6
14	99.E0103	.Nut, Locking Flange 1/2-13	8
15	99.SF0606-1	.Bolt, SMF 3/8-16 USS x 3/4	4
16	99.SF06	.Nut, SRF 3/8-16 USS	4
17	95.08	.Washer, Flat 1/2 SAE	20
18	99.SF05	.Nut, SRF 5/16-18 USS	4
19	90.0512-2	.Bolt, 5/16-18 USS x 1-1/2 Tap	2
20	KN-1338	.Spacer, 1/2 ID x 1-1/8 OD x 3/8 T	2
21	KN-1339	.Plate, Rollbar Lock	2
22	90.0822	.Bolt, 1/2-13 USS x 2-3/4	2
23	90.0814	.Bolt, 1/2-13 USS x 1-3/4	4
24	90.0810	.Bolt, 1/2-13 USS x 1-1/4	2
25	99.SF08	.Nut, SRF 1/2-13 USS	6
26	KN-6026	.Frame, Rollbar Mount	1
27	KN-6027	.Frame, Canopy	1
28	KN-6055	.Bracket, Rollbar Lock LH	1
29	KN-6053	.Bracket, Rollbar Lock RH	1
30	KN-6035	.Link, Rod 20.00"	2

OPTIONS

ILLUSTRATED DRAWING 70.4170 Canopy Fan Kit

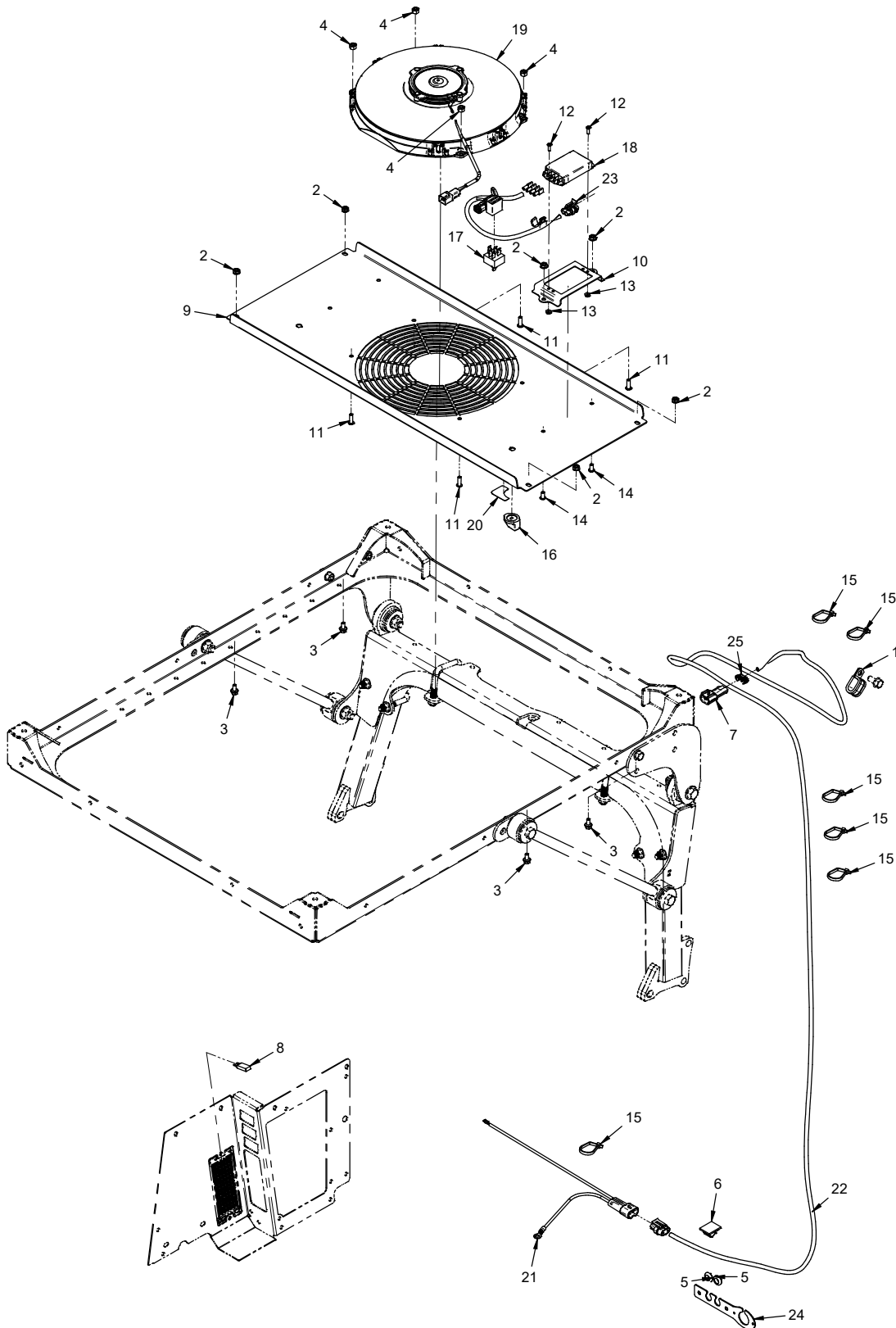

OPTIONS

70.4170 Canopy Fan Kit

REF.	PART NO.	DESCRIPTION	QTY.
1	11.0046	.Clamp, Cushioned 1/2" 2-Tube	1
2	99.SF04	.Nut, SRF 1/4-20 USS	6
3	99.SF0404-1	.Bolt, SMF 1/4-20 X 1/2.	4
4	99.A04N	.Locknut, Nylon 1/4-20.	4
5	05.0136	.Grommet, 7/16ID, 3/4OD, 1/4Thk.	2
6	30.0217	.Clamp, Wire Mt Adh. 1/2 Gray.	1
7	30.0322	.Connector, MP280 Male Body.	1
8	30.0445	.Breaker, Circuit 30 Amp Mini.	1
9	KN-1247	.Mount, Cooling Fan.	1
10	KN-1248	.Mount, Resistor.	1
11	99.0406	.Bolt, 1/4-20 x 3/4 BSCS	4
12	99.K0041	.Machine Screw, #8-32 X 1/2.	2
13	99.E0104	.Nut, Jam #8-32 Nylon Lock.	2
14	99.0404	.Bolt, 1/4-20 x 1/2 BSCS	2
15	30.0204	.Tyton Tie, #50 .190 x 12"	6
16	47.0386	.Knob, Fan Speed / Temperature	1
17	31.0077	.Switch, Fan Speed	1
18	35.0162	.Resistor, 4 Speed	1
19	37.0071	.Fan, Electric 12"	1
20	00.0676	.Decal, Fan Switch.	1
21	32.0129	.Harness, Wire Tractor To KW450.	1
22	32.0229	.Harness, Wire Canopy Fan.	1
23	32.0232	.Harness, Wire Canopy Fan Top	1
24	KN-1281	.Cover, Wire Harness Access.	1
25	30.0326	.Clip, Mp280 Connector 2 Pos	1

OPTIONS

ILLUSTRATED DRAWING

70.4171 Strobe Light for Canopy Kit

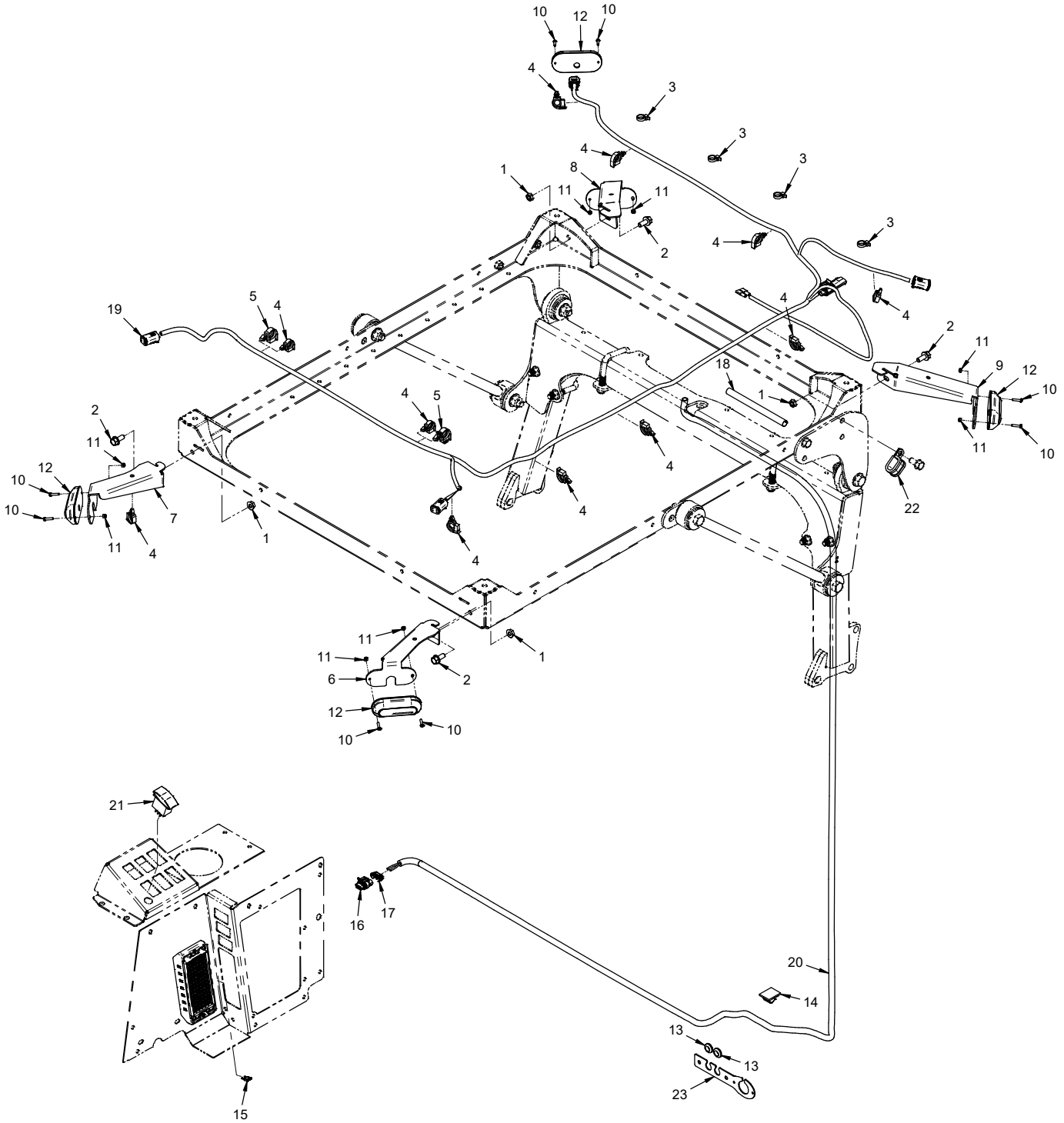

OPTIONS

70.4171 Strobe Light for Canopy Kit

REF.	PART NO.	DESCRIPTION	QTY.
1	99.SF05	Nut, SRF 5/16-18 USS	4
2	99.SF0506-1	Bolt, SMF 5/16-18 USS x 3/4	4
3	30.0037	Tyton Tie, #50 .18 x 8 Black	4
4	30.0135	Clamp, Loom 3/8 Rosebud Mount	11
5	30.0137	Clamp, Loom 5/8 Rosebud Mount (if equipped with Strobe Lights)	2
6	KN-1262	Mount, Strobe Left Front	1
7	KN-1264	Mount, Strobe Right Front	1
8	KN-1263	Mount, Strobe Right Rear	1
9	KN-1265	Mount, Strobe Left Rear	1
10	99.K0166	Machine Screw, #6-32 X 5/8 SS	8
11	99.E0118	Locknut, Nylon #6-32 SS	8
12	33.0082	Light, Strobe Amber Low Profile	4
13	05.0136	Grommet, 7/16ID, 3/4OD, 1/4Thk	2
14	30.0217	Clamp, Wire Mt Adh. 1/2 Gray	1
15	30.0334	Fuse, 15 Amp Mini Blue	1
16	30.0323	Connector, MP280 Female Body	1
17	30.0326	Clip, Mp280 Connector 2 Pos	1
18	30.0131	Loom, Split Corrugated 3/8 x 6"	1
19	32.0233	Harness, Wire Canopy Strobe	1
20	32.0117	Harness, Wire Strobe Light	1
21	31.0053	Switch, Rocker On/Off	1
22	11.0046	Clamp, Cushioned 1/2" 2-Tube	1
23	KN-1281	Cover, Wire Harness Access	1

OPTIONS

ILLUSTRATED DRAWING 70.4172 Front Work Light for Canopy Kit

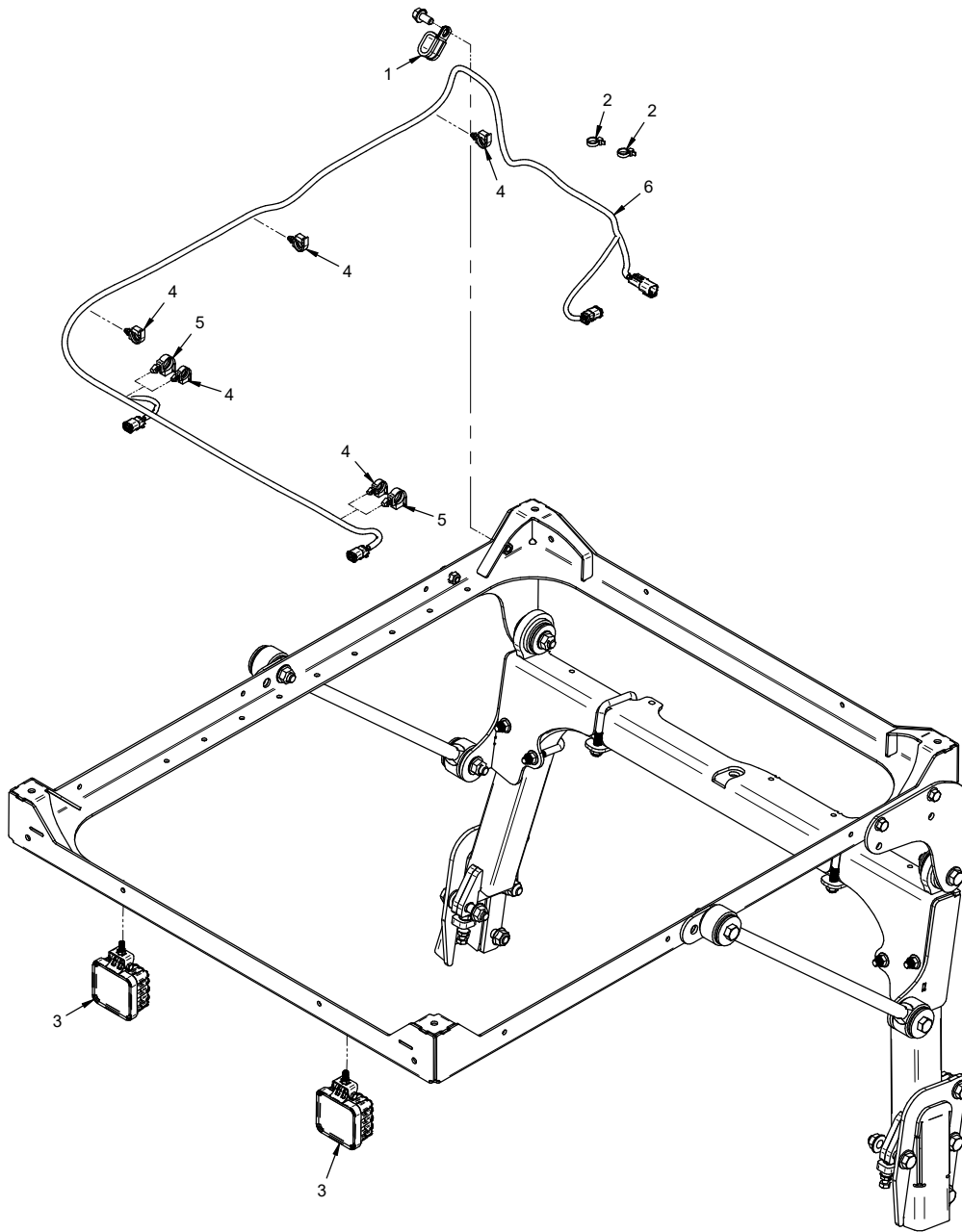

OPTIONS

70.4172 Front Work Light for Canopy Kit

REF.	PART NO.	DESCRIPTION	QTY.
1	11.0046	Clamp, Cushioned 1/2" 2-Tube	1
2	30.0037	Tyton Tie, #50 .18 x 8 Black	2
3	33.0087	Light, LED Flood with Bracket	2
4	30.0135	Clamp, Loom 3/8 Rosebud Mount	5
5	30.0137	Clamp, Loom 5/8 Rosebud Mount (if equipped with Strobe Lights)	2
6	32.0230	Harness, Wire Work Lights	1

OPTIONS

ILLUSTRATED DRAWING 70.4167 Suspension Seat Kit

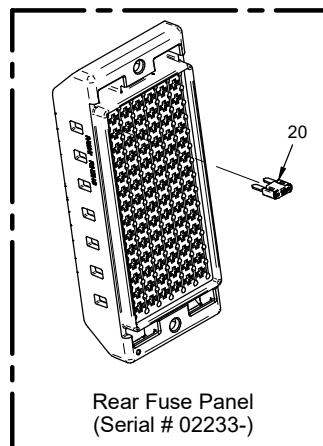
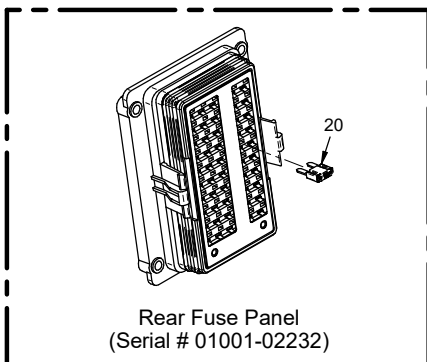
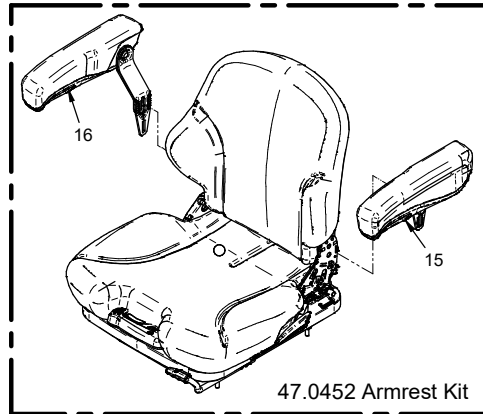
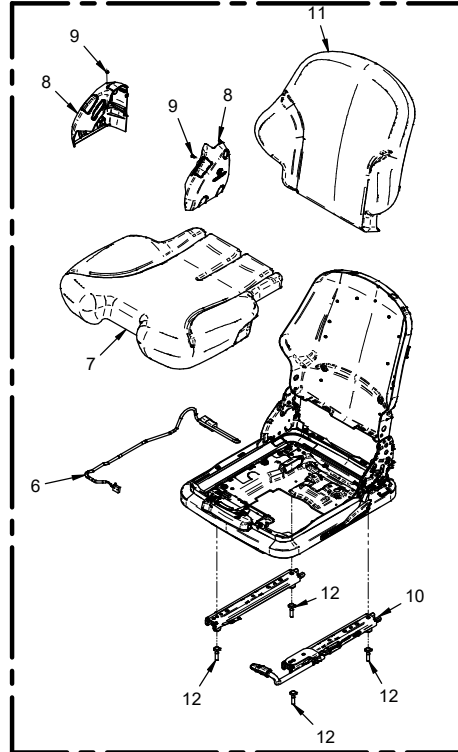
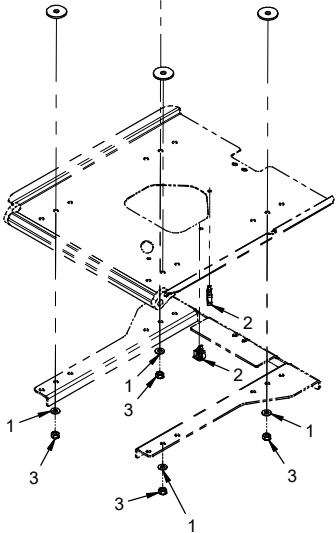
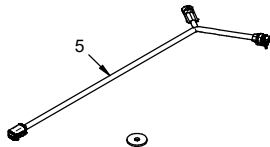
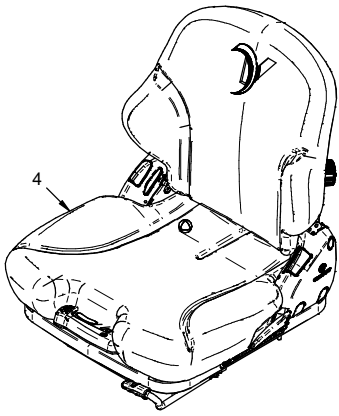

OPTIONS

70.4167 Suspension Seat Kit

REF.	PART NO.	DESCRIPTION	QTY.
1	95.05	Washer, Flat 5/16 SAE	4
2	30.0135	Clamp, Loom 3/8 Rosebud Mount	2
3	99.A05N	Locknut, Nylon 5/16-18 USS	4
3	99.M0068	Nut, M8 x 1.25 Nylon Lock	4
4	47.0450	Seat, Suspension	1
5	32.0212	Harness, Wire Grammer Seat	1
6	31.0075	Switch, Seat Asm.	1
7	47.0501	Cushion, Seat Heated	1
8	47.0482	Cover, Left & Right Side (Set)	1
9	04.0049	Rivet, Side Covers for Grammer Seat	2
10	47.0510	Rail Set, Slide Adjustment	1
11		Seat Back for 47.0450 Seat	1
12	99.K0188	Bolt, SQHD 5/16-18 x 1-1/4	4
15	47.0452-L	Armrest, Left - Suspension Seat	1
16	47.0452-R	Armrest, Right - Suspension Seat	1
20	30.0333	Fuse, 10 Amp Mini Red	1

OPTIONS

ILLUSTRATED DRAWING 39.56114 3N1 Hitch

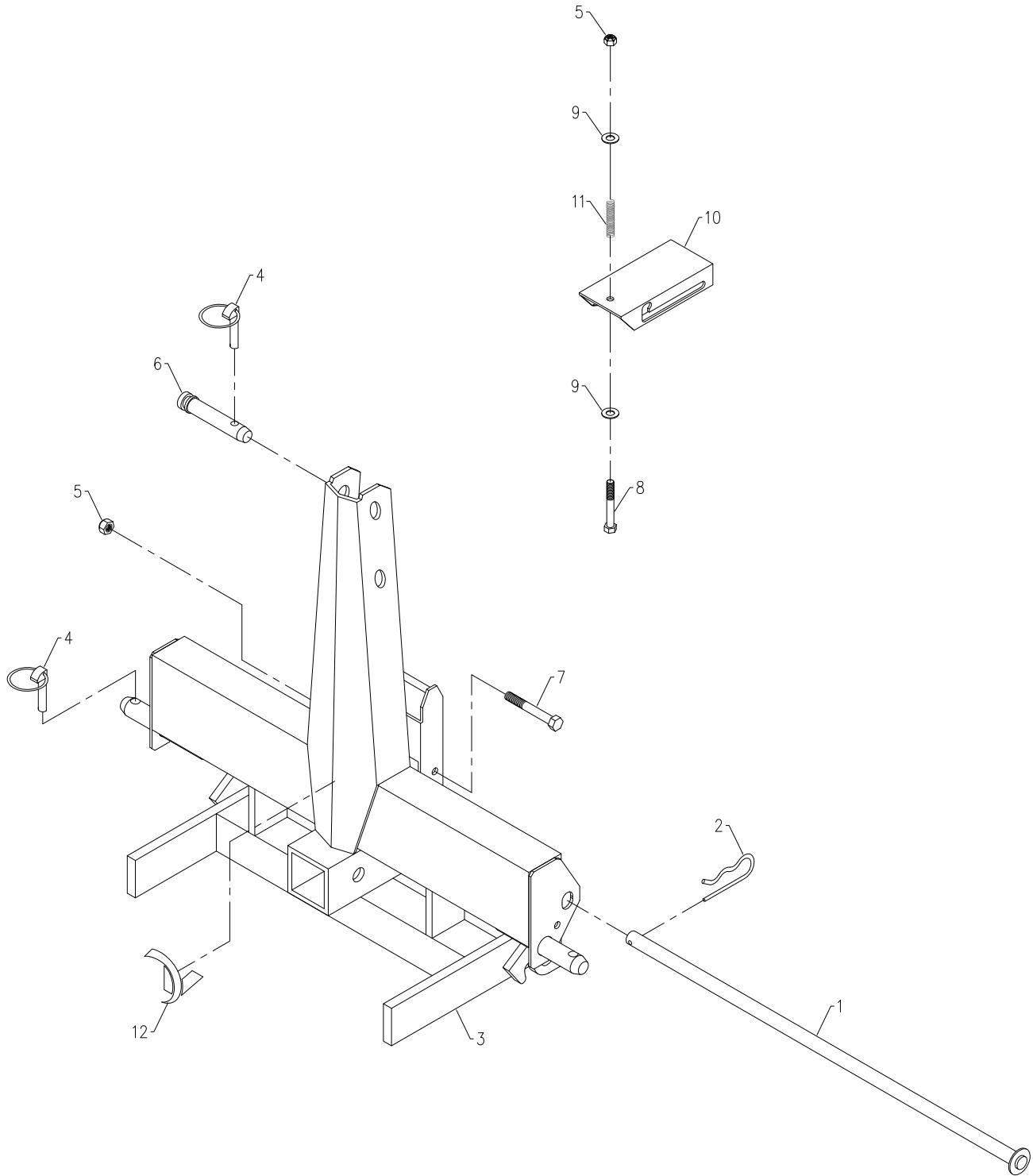

OPTIONS

39.56114 3N1 Hitch

REF.	PART NO.	DESCRIPTION	QTY.
1	64.1017	.PIN, SECURE WEIGHTS 5/8 X 24"L	1
2	02.HP0420	.HAIRPIN, 1/8 X 2-1/2	1
3	62.0925	.FRAME, 3N1 TOW HITCH	1
4	03.0005	.PIN, LINCH	3
5	99.A05	.LOCKNUT, STOVER 5/16-18 USS	2
6	03.0004	.PIN, TOP LINK CATEGORY 1	1
7	90.0526	.BOLT, 5/16-18 USS X 3-1/4	1
8	90.0524	.BOLT, 5/16-18 USS X 3	1
9	95.05	.WASHER, FLAT 5/16 SAE	2
10	64.1101	.LATCH, LEVER LOCK	1
11	41.0021	.SPRING, COMP 1/2 OD X 2-3/4 LG	1
12	00.0192	.DECAL, V-DECAL DIE CUT BLUE	1

OPTIONS

ILLUSTRATED DRAWING 39.56116 Rear Counterweight Bar

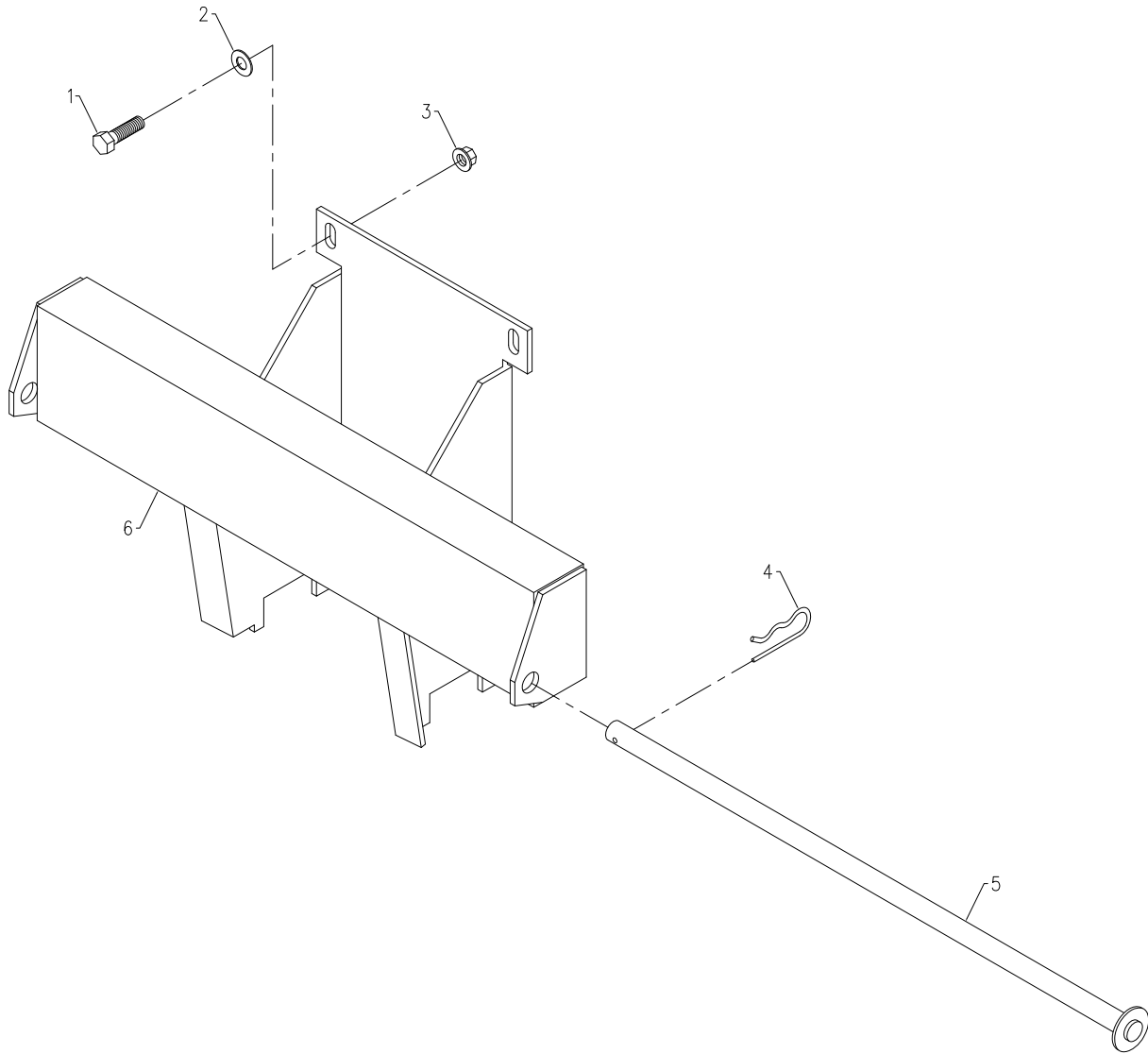

OPTIONS

70.39.56116 Rear Counterweight Bar

REF.	PART NO.	DESCRIPTION	QTY.
1	90.0606	BOLT, 3/8-16 USS X 3/4	2
2	95.06	WASHER, FLAT 3/8 SAE	2
3	99.SF06	NUT, SRF 3/8-16 USS	2
4	02.HP0420	HAIRPIN, 1/8 X 2 1/2	1
5	64.1040	PIN, WEIGHT SECURE 21"L	1
6	62.0955	FRAME, REAR WT BRACKET	1

OPTIONS

ILLUSTRATED DRAWING 70.2016 Trailer Mover Hitch

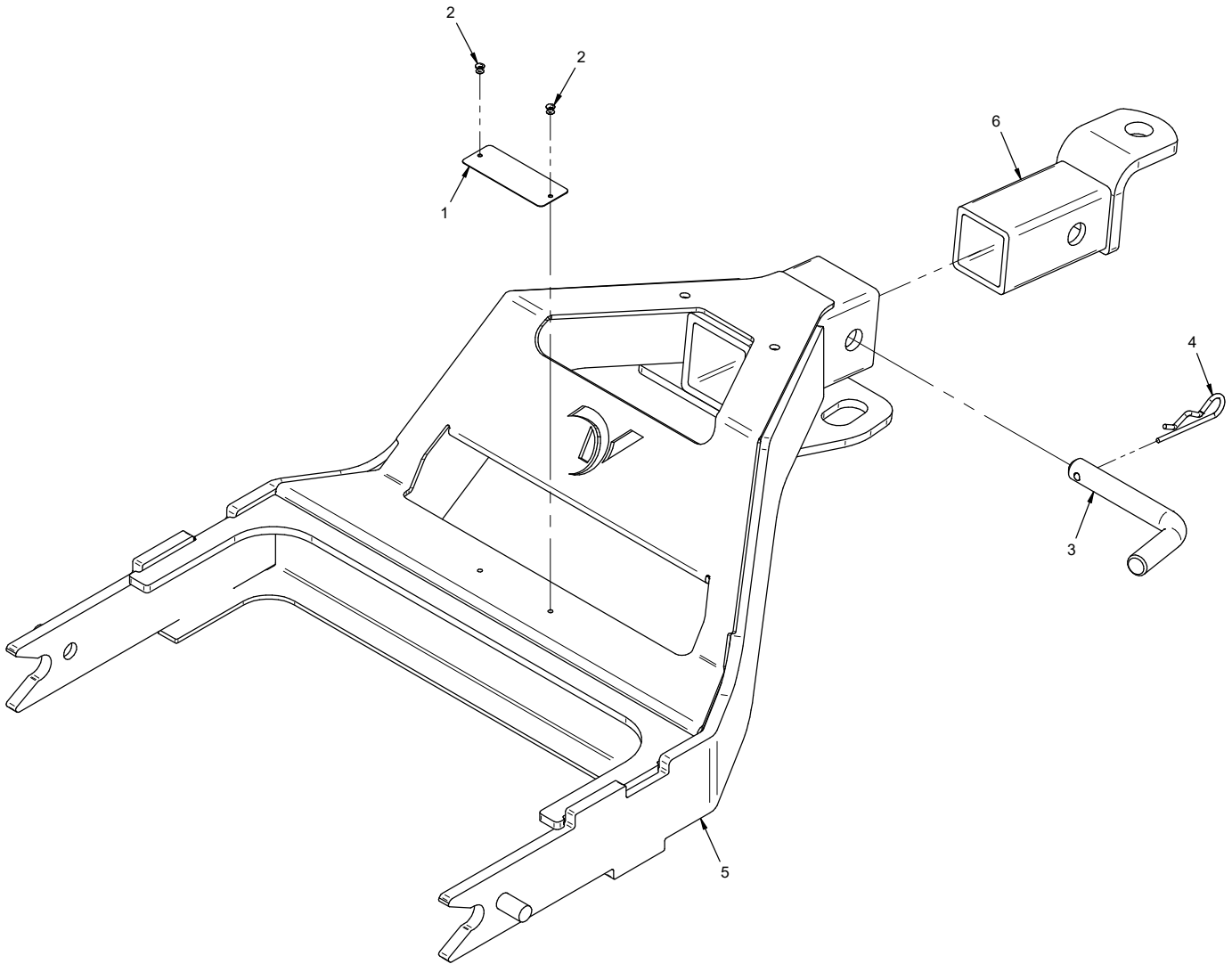

OPTIONS

70.2016 Trailer Mover Hitch

REF.	PART NO.	DESCRIPTION	QTY.
1	N/A	Plate, Ventrac Serial Number	1
2	04.0007	Rivet, Pop Dome 1/8 X 1/8 S.S.	2
3	03.0014	Pin, Hitch 5/8" X 3" Usable	1
4	02.HP0420	Hairpin, 1/8 X 2 1/2	1
5	62.1461	Frame, Tow Hitch	1
6	62.0968	Hitch, Rear	1

OPTIONS

ILLUSTRATED DRAWING 70.4175 Front Hitch Valve Kit (Serial # 01001-05059)

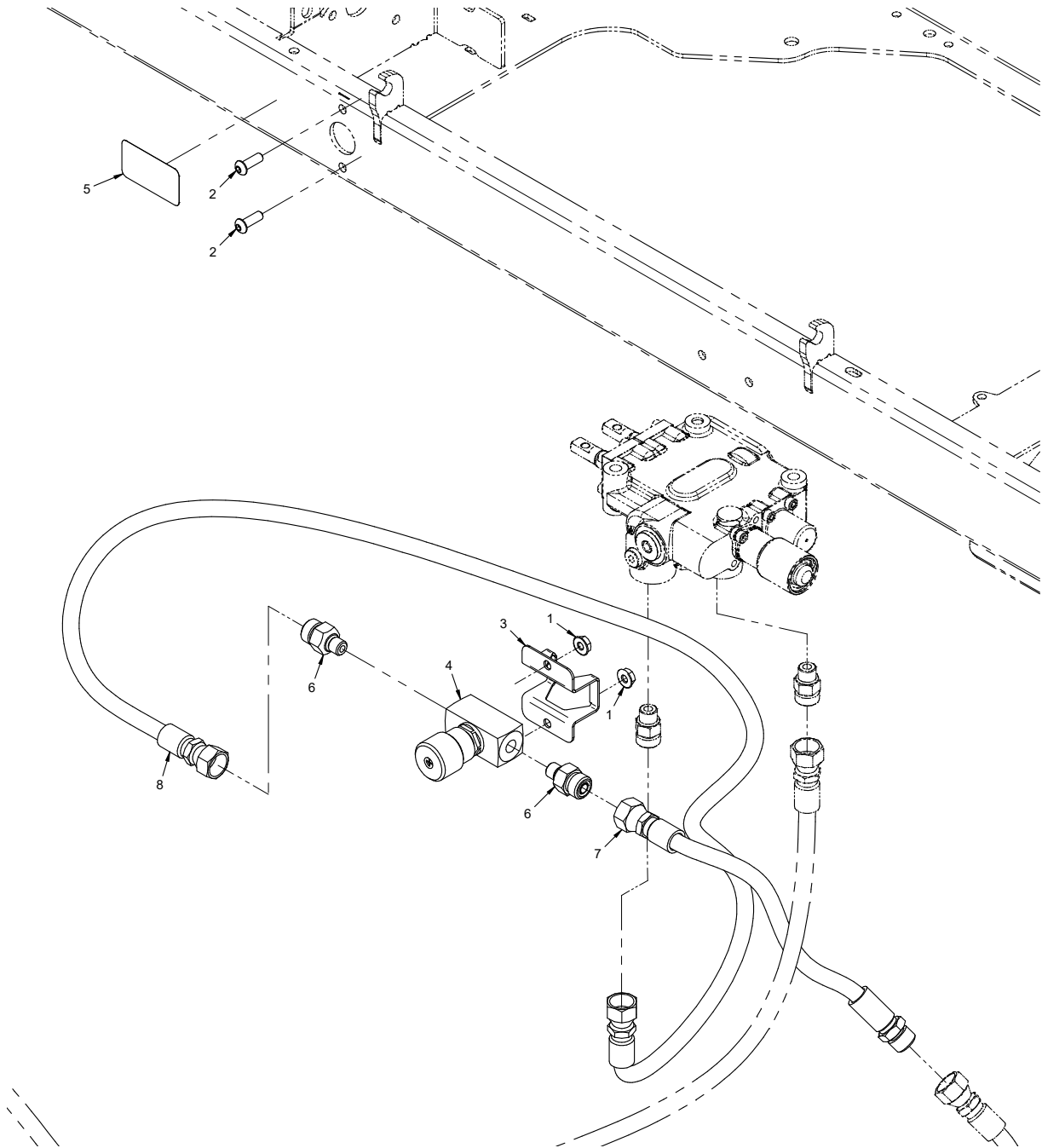

OPTIONS

70.4175 Front Hitch Valve Kit (Serial # 01001-05059)

REF.	PART NO.	DESCRIPTION	QTY.
1	99.SF04	Nut, SRF 1/4-20 USS	2
2	99.0406	Bolt, 1/4-20 x 3/4 BSCS	2
3	64.1719	Bracket, Needle Valve	1
4	23.0161	Valve, Needle	1
5	00.0329	Decal, Front Hitch Valve	1
6	25.FF6400-06-04	Fitting, Connector -06MF x -04MB	2
7	20.0413	Hose, 1/4x8.00 SAE 100R17AR	2
8	20.0397	Hose, 1/4x48.00 SAE 100R17AR	1

OPTIONS

ILLUSTRATED DRAWING 70.4187 Front Hitch Valve Kit (Serial # 05060-)

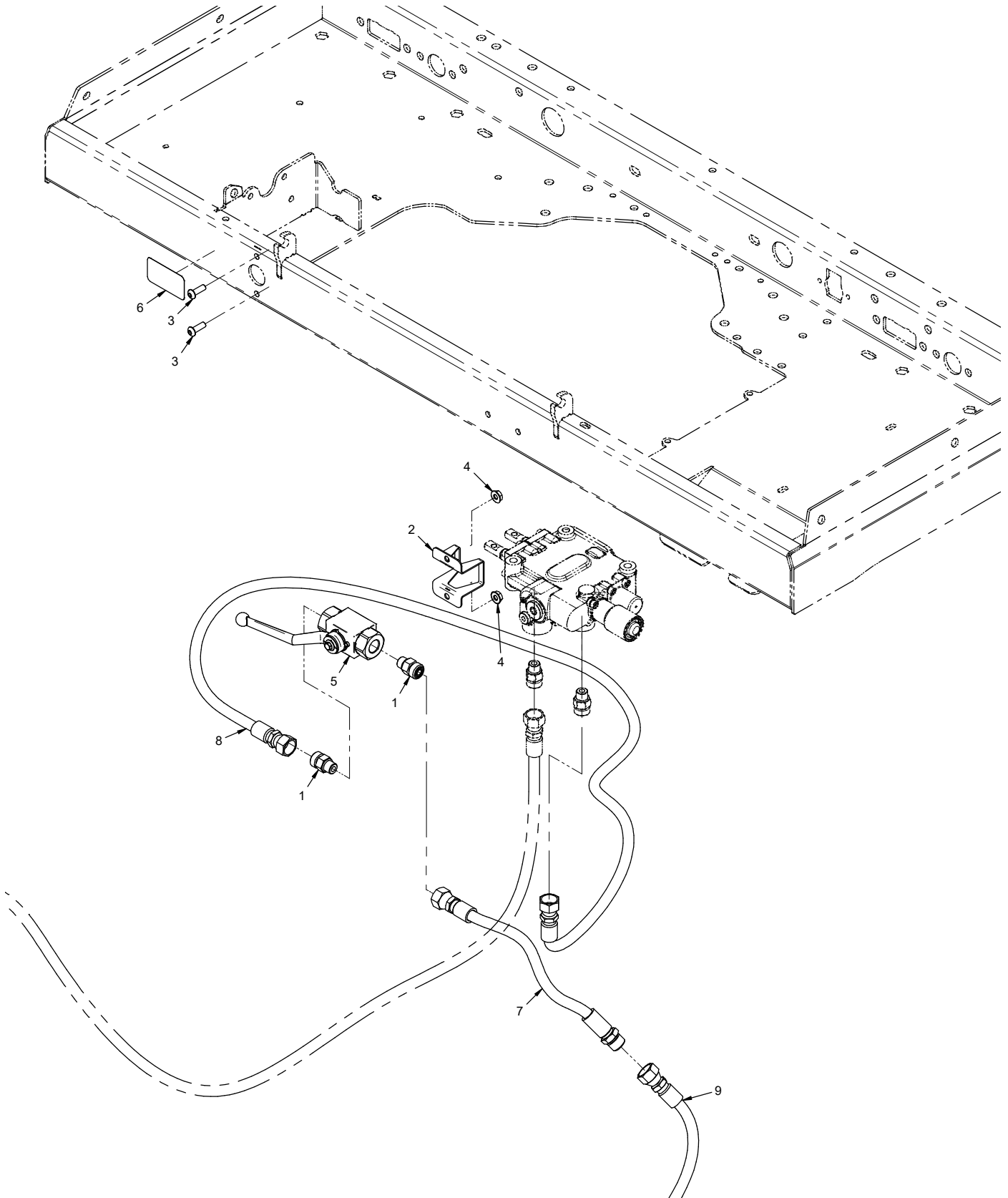

OPTIONS

70.4187 Front Hitch Valve Kit (Serial # 05060-)

REF.	PART NO.	DESCRIPTION	QTY.
1	25.FF6400-06-06	Fitting, Connector -06MFF x -06MB	2
2	KN-1471	Bracket, Ball Valve	1
3	99.0406	Bolt, 1/4-20 x 3/4 BSCS	2
4	99.SF04	Nut, SRF 1/4-20 USS	2
5	23.0216	Valve, Ball	1
6	00.0329	Decal, Front Hitch Valve	1
7	20.0423	Hose, 3/8x8.00 SAE 100R17AR	1
8	20.0424	Hose, 3/8x48.00 SAE 100R17AR	1
9	20.0425	Hose, 3/8x58.00 SAE 100R17AR	1

OPTIONS

ILLUSTRATED DRAWING 70.4166 Strobe Light Kit

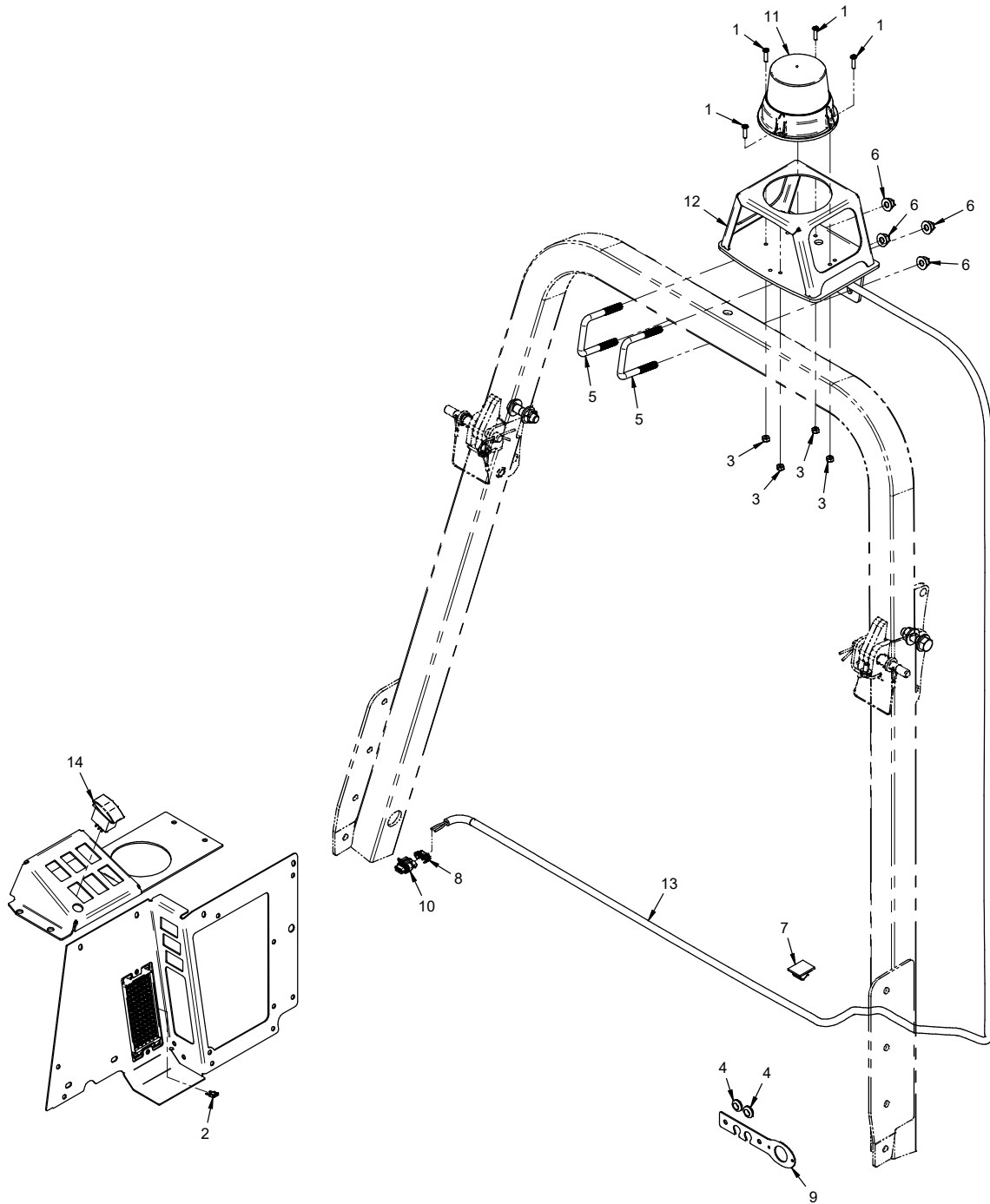

OPTIONS

70.4166 Strobe Light Kit

REF.	PART NO.	DESCRIPTION	QTY.
1	99.K0047	Machine Screw, #10-32 X 3/4	4
2	30.0334	Fuse, 15 Amp Mini Blue	1
3	99.A1032N	Locknut, Nylon 10-32 Stainless	4
4	05.0136	Grommet, 7/16ID, 3/4OD, 1/4Thk	2
5	11.0053	U-Bolt, 3/8-16 2-1/16" ID SQ Bend	2
6	99.E0136	Nut, Nylon Locking Flange 3/8-16	4
7	30.0217	Clamp, Wire Mt Adh. 1/2 Gray	1
8	30.0326	Clip, Mp280 Connector 2 Pos	1
9	KN-1281	Cover, Wire Harness Access	1
10	30.0323	Connector, MP280 Female Body	1
11	33.0073	Light, Strobe Amber	1
12	62.1512	Frame, Light Bar	1
13	32.0117	Harness, Wire Strobe Light	1
14	31.0053	Switch, Rocker On/Off	1
15	30.0207	Terminal, .25 Pushon F 16-14GA (not shown)	1
16	30.0249	Terminal, .25 Pushon M 16-14GA (not shown)	1

OPTIONS

ILLUSTRATED DRAWING 70.4173 Work Light LED Kit

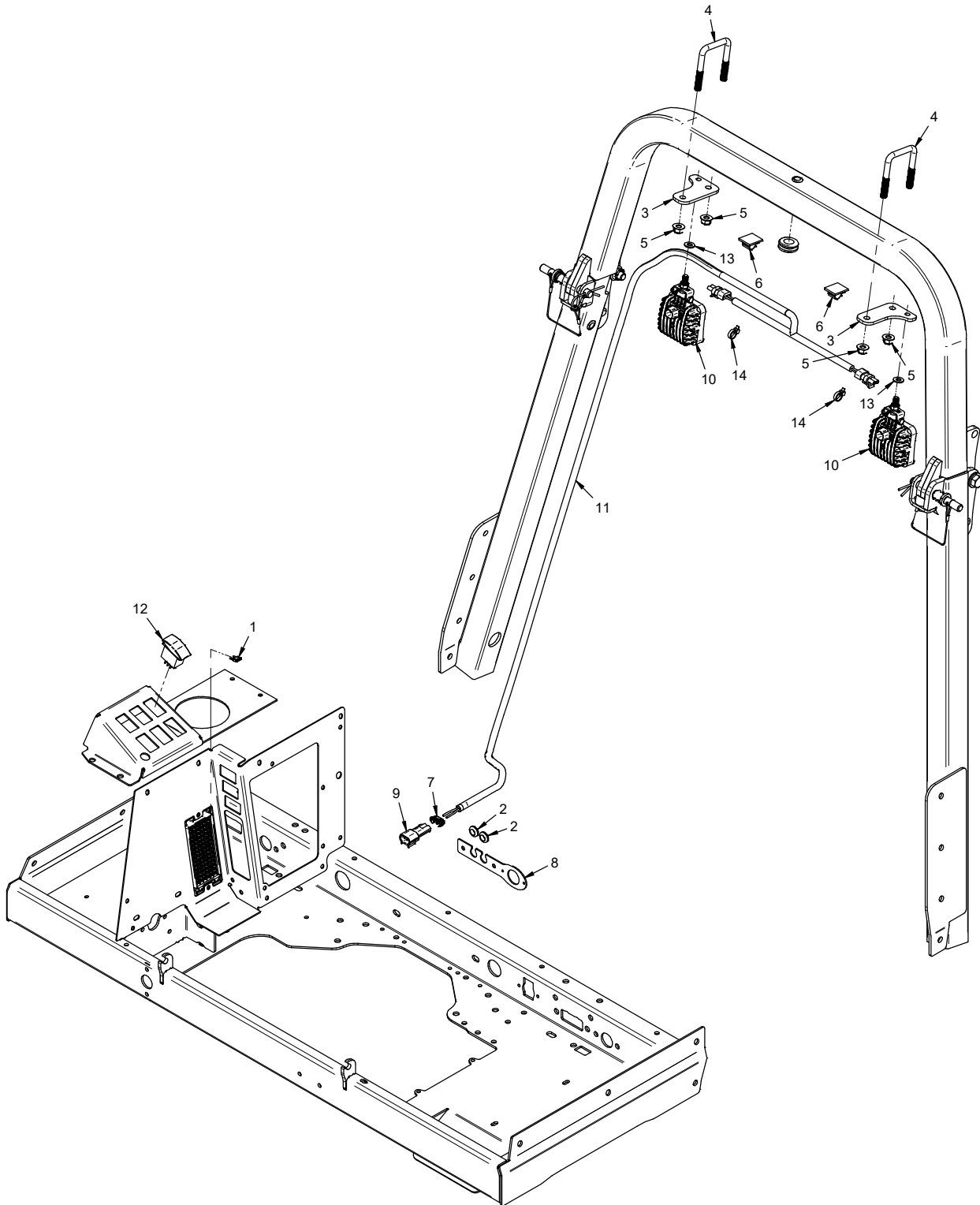

OPTIONS

70.4173 Work Light LED Kit

REF.	PART NO.	DESCRIPTION	QTY.
1	30.0334	Fuse, 15 Amp Mini Blue	1
2	05.0136	Grommet, 7/16ID, 3/4OD, 1/4Thk	2
3	KN-1225	Plate, Rollbar Mount	2
4	11.0053	U-Bolt, 3/8-16 2-1/16" ID SQ Bend	2
5	99.E0136	Nut, Nylon Locking Flange 3/8-16	4
6	30.0217	Clamp, Wire Mt Adh. 1/2 Gray	2
7	30.0326	Clip, Mp280 Connector 2 Pos	1
8	KN-1281	Cover, Wire Harness Access	1
9	30.0322	Connector, MP280 Male Body	1
10	33.0087	Light, LED Flood with Bracket	2
11	32.0231	Harness, Wire Work Light	1
12	31.0053	Switch, Rocker On/Off	1
13	95.05	Washer, Flat 5/16 SAE	2
14	30.0037	Tyton Tie, #50 .18 x 8 Black	2

OPTIONS

ILLUSTRATED DRAWING 70.4184 Tool Box Mount, Small

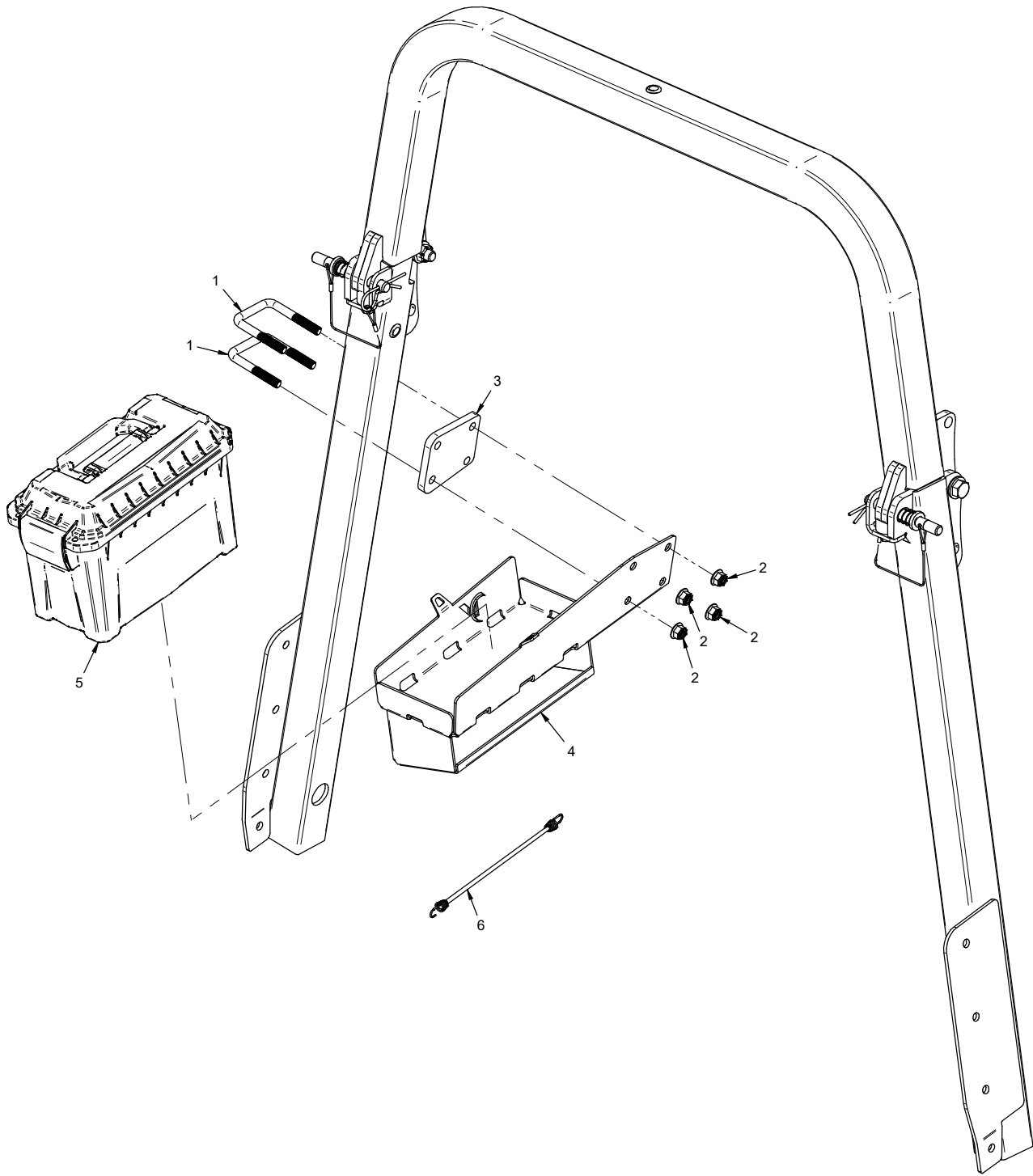

OPTIONS

70.4184 Tool Box Mount, Small

REF.	PART NO.	DESCRIPTION	QTY.
1	11.0053	U-Bolt, 3/8-16 2-1/16" ID SQ Bend	2
2	99.E0136	Nut, Nylon Locking Flange 3/8-16	4
3	KN-1332	Spacer, Small Toolbox Frame	1
4	KN-6039	Frame, Toolbox Small w/Tray	1
5	47.0507	Toolbox, Side ROPS	1
6	47.0517	Strap, Bungee Cord 12"	1

OPTIONS

ILLUSTRATED DRAWING 70.4185 Tool Box Mount, Large

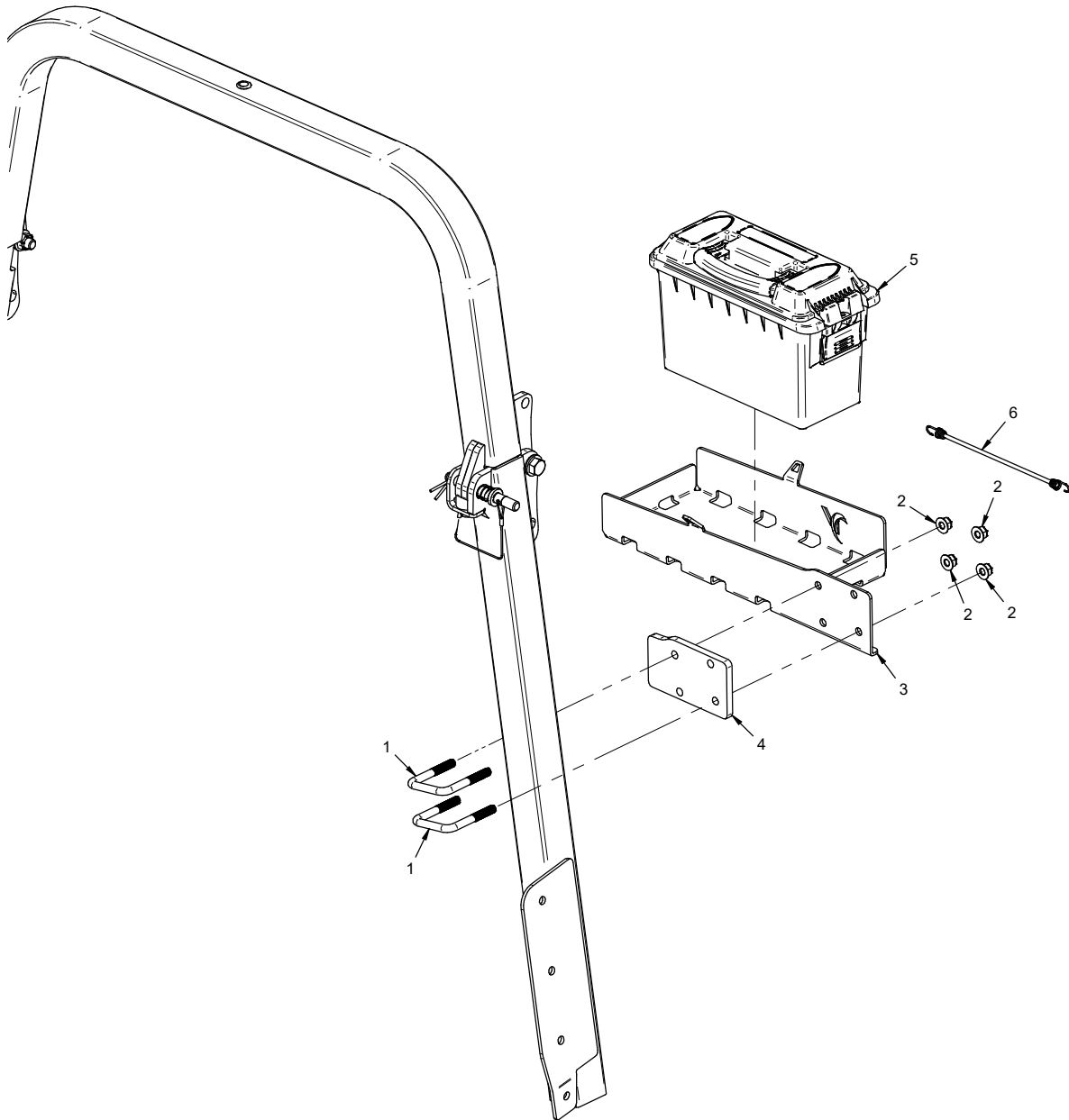

OPTIONS

70.4185 Tool Box Mount, Large

REF.	PART NO.	DESCRIPTION	QTY.
1	11.0053	U-Bolt, 3/8-16 2-1/16" ID SQ Bend	2
2	99.E0136	Nut, Nylon Locking Flange 3/8-16	4
3	KN-1307	Frame, Toolbox Large	1
4	KN-1411	Spacer, Large Toolbox Frame	1
5	47.0506	Toolbox, Rear ROPS	1
6	47.0518	Strap, Bungee Cord 18"	1

OPTIONS

ILLUSTRATED DRAWING 70.4161 12 Volt Front Plug Kit

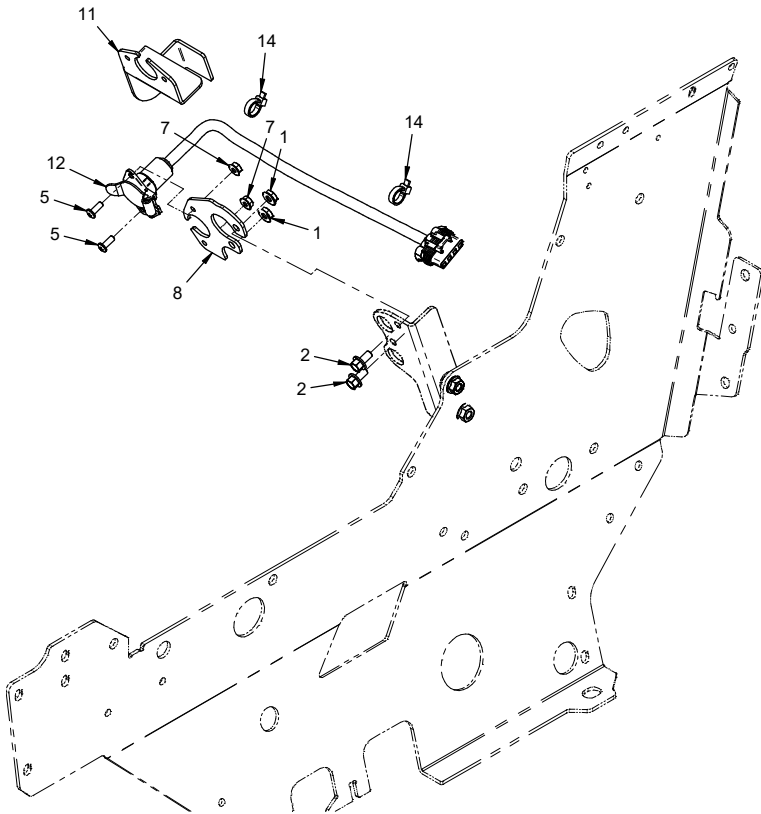
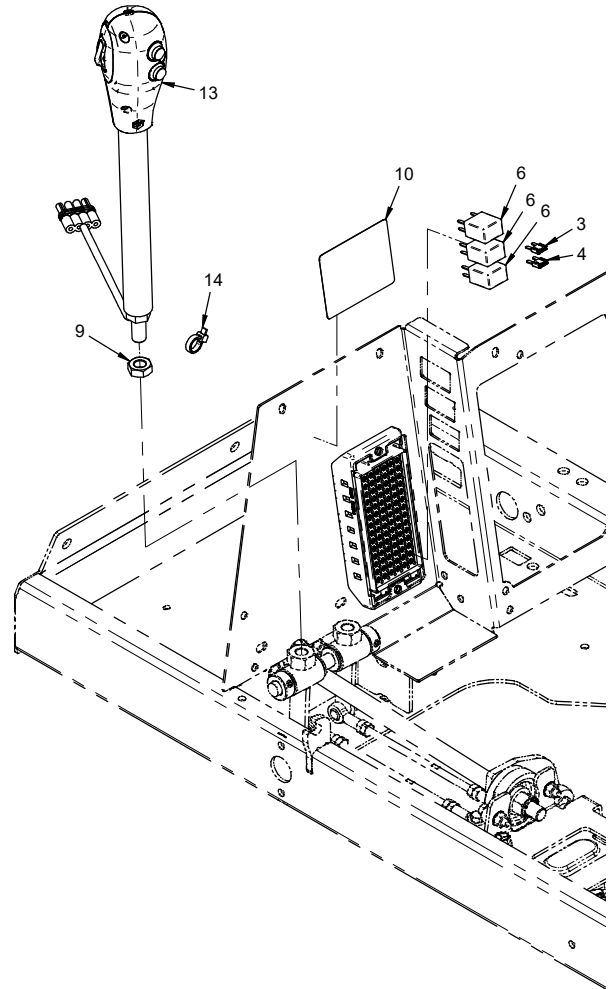
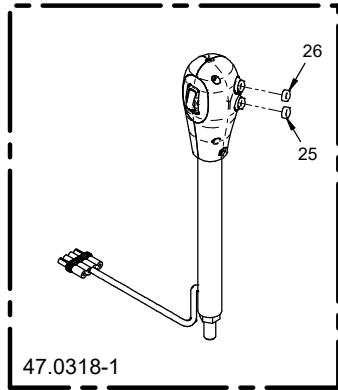

OPTIONS

7034161 12 Volt Front Plug Kit

REF.	PART NO.	DESCRIPTION	QTY.
1	99.SF04	Nut, SRF 1/4-20 USS	2
2	99.SF0404-1	Bolt, SMF 1/4-20 X 1/2	2
3	30.0332	Fuse, 5 Amp Mini Tan	1
4	30.0334	Fuse, 15 Amp Mini Blue	1
5	99.K0062	Machine Screw, #10-32 X 1/2	2
6	35.0117	Relay, 12v 35/20 Amp 280 Micro	3
7	99.E0035	Nut, SF #10-32	2
8	KN-1099	Bracket, 12v 4 Pin Socket Mt	1
9	99.E0058	Nut, Jam 1/2-13 USS	1
10	00.0328	Decal, Handle 12V	1
11	KN-1160	Bracket, Dual Aux 12V (if equipped with Dual Front Hydraulics)	1
12	32.0114	Harness, Wire 12V Front	1
13	47.0318-1	Handle, SDLA Grip & Post	1
14	30.0037	Tyton Tie, #50 .18 x 8 Black	3
25	47.0349	Button, Switch Orange	1
26	47.0348	Button, Switch Yellow	1

OPTIONS

ILLUSTRATED DRAWING 70.4164 Dual Front Hydraulic Aux Kit

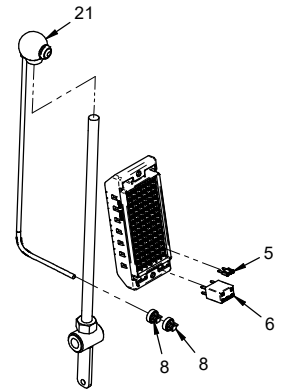
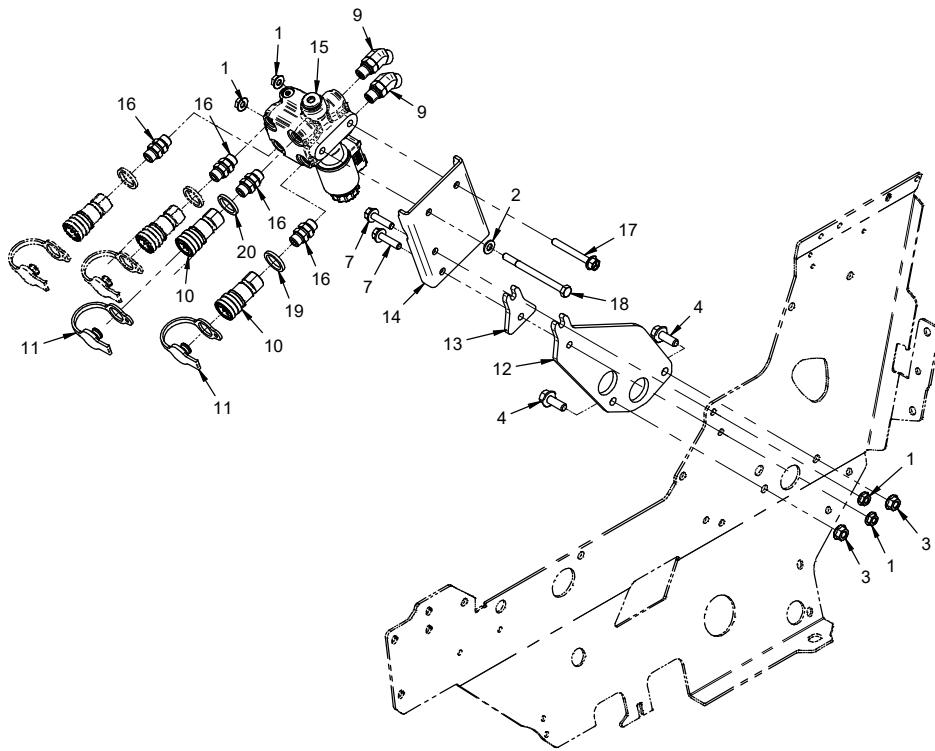

OPTIONS

70.4164 Dual Front Hydraulic Aux Kit

REF.	PART NO.	DESCRIPTION	QTY.
1	99.SF05	Nut, SRF 5/16-18 USS	4
2	95.05	Washer, Flat 5/16 SAE	1
3	99.SF06	Nut, SRF 3/8-16 USS	2
4	99.SF0608-1	Bolt, SMF 3/8-16 x 1	2
5	30.0333	Fuse, 10 Amp Mini Red	1
6	35.0117	Relay, 12v 35/20 Amp 280 Micro	1
7	99.SF0510-1	Bolt, SMF 5/16-18 USS X 1-1/4	2
8	30.0037	Tyton Tie, #50 .18 x 8 Black	2
9	25.FF6802-06-06	Fitting, 45 Elbow - 6Mff X 6Mb	2
10	23.0197	Coupler, Hyd Quick Female 1/4 ORB	2
11	23.0126	Plug, Dust for 23.0106	2
12	KN-1342	Plate, Support Dual Aux Bracket	1
13	KN-1112	Plate, Dual Aux Bracket Mount	1
14	KN-1111	Bracket, Dual Valve Mount	1
15	23.0196	Valve, Diverter	1
16	25.6403-06-06	Fitting, St Union 06MB x 06MB	4
17	99.SF0520-1	Bolt, SMF 5/16-18 x 2-1/2	1
18	90.0532	Bolt, Hex 5/16-18 UNC x 4"	1
19	05.0192	Washer, .905 ID x 1.170 x .140 Black	1
20	05.0193	Washer, .905 ID x 1.170 x .140 White	1
21	47.0336	Handle, Grip w/Switch	1

OPTIONS

ILLUSTRATED DRAWING 70.4162 Directional/Hazard ECE Light Kit

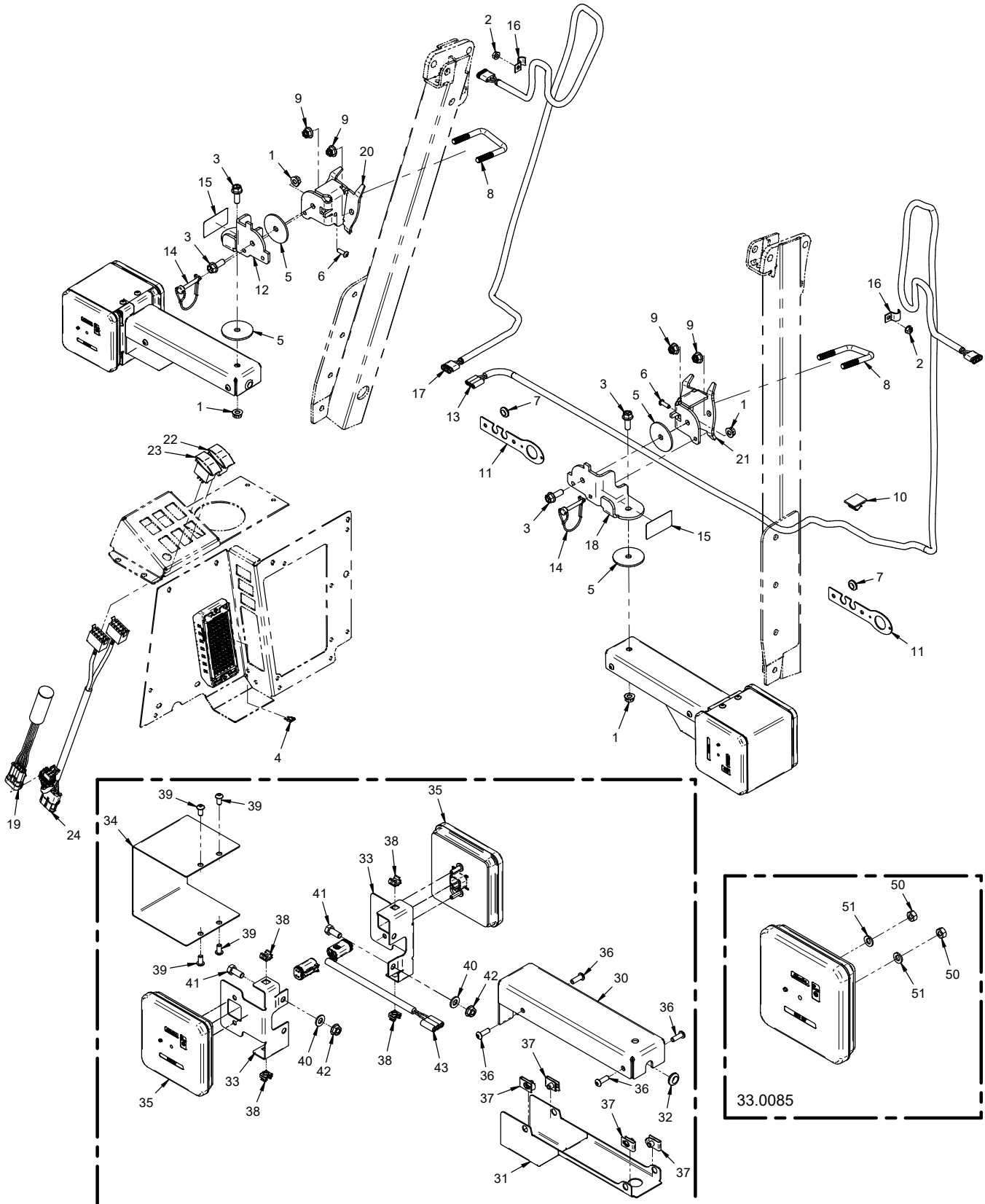

OPTIONS

70.4162 Directional/Hazard ECE Light Kit

REF.	PART NO.	DESCRIPTION	QTY.
1	99.E0082	.Nut, Locking Flange 3/8-16	4
2	99.E0101	.Nut, Locking Flange 1/4-20	2
3	99.SF0608-1	.Bolt, SMF 3/8-16 x 1	4
4	30.0333	.Fuse, 10 Amp Mini Red	1
5	05.0002	.Washer, Fric. 2-1/4 X 13/32	4
6	99.0406	.Bolt, 1/4-20 x 3/4 BSCS	2
7	05.0136	.Grommet, 7/16ID, 3/4OD, 1/4Thk	4
8	11.0053	.U-Bolt, 3/8-16 2-1/16" ID SQ Bend	2
9	99.E0136	.Nut, Nylon Locking Flange 3/8-16	4
10	30.0217	.Clamp, Wire Mt Adh. 1/2 Gray	1
11	KN-1281	.Cover, Wire Harness Access	2
12	64.2023	.Bracket, Directional Pivot RH	1
13	30.0423	.Connector, WPAK 3 Pos Male	1
14	03.0009	.Pin, Safety Snap 1/4 X 1-3/8	2
15	00.0364	.Decal, Warning Pinch Point	2
16	11.0072	.Clamp, 1/2 Loop Vinyl	2
17	30.0422	.Connector, Wpak 3 Pos Female	1
18	64.2024	.Bracket, Directional Pivot LH	1
19	35.0161	.Module, Directional/Hazard Light	1
20	64.2025	.Bracket, Rollbar Mount RH	1
21	64.2026	.Bracket, Rollbar Mount LH	1
22	31.0055	.Switch, Rocker On/Off/On	1
23	31.0053	.Switch, Rocker On/Off	1
24	32.0118	.Harness, Wire Directional	1
30	40.0413	.Arm, Directional Light	1
31	60.1306	.Cover, Directonal Signal Arm	1
32	05.0136	.Grommet, 7/16ID, 3/4OD, 1/4Thk	4
33	64.2028	.Bracket, Signal Light	2
34	60.2027	.Cover, Signal Light	1
35	33.0085	.Light, Asm LED Single Face - Amber	4
36	99.0406	.Bolt, 1/4-20 x 3/4 BSCS	8
37	99.E0046	.Nut, "U" 1/4-20 Extruded	8
38	99.E0145	.Nut, Cage 1/4-20 (.025-.063")	8
39	99.0404	.Bolt, 1/4-20 x 1/2 BSCS	8
40	95.05	.Washer, Flat 5/16 SAE	4
41	90.0506	.Bolt, 5/16-18 USS x 3/4"	4
42	99.SF05	.Nut, SRF 5/16-18 USS	4
43	32.0217	.Harness, 4500 Directional/Hazard ECE	2
50	99.M0031	.Nut, M6 X 1.00	8
51	96.04	.Washer, Lock 1/4	8

OPTIONS

ILLUSTRATED DRAWING 70.4181 Back-Up Alarm Kit

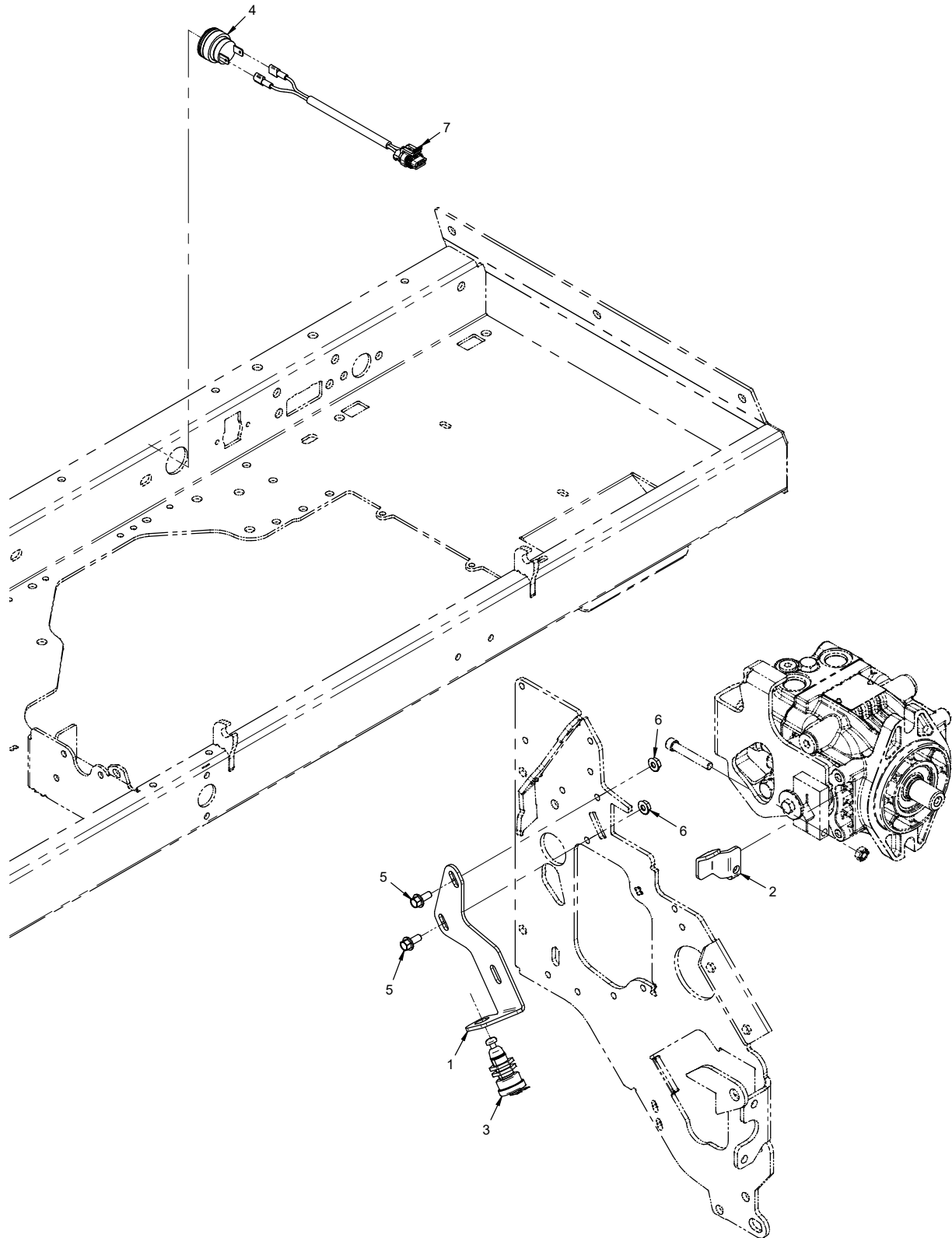

OPTIONS

70.4181 Back-Up Alarm Kit

REF.	PART NO.	DESCRIPTION	QTY.
1	KN-1385	.Bracket, Backup Switch Mount	1
2	KN-1386	.Bracket, Backup Switch Actuator	1
3	31.0044	.Switch, Push Button - Neutral	1
4	35.0125	.Alarm, Audible Pulse Panel Mt	1
5	99.SF0405-1	.Bolt, SMF 1/4-20 X 5/8.	2
6	99.SF04	.Nut, SRF 1/4-20 USS	2
7	32.0122	.Harness, Wire Backup Alarm	1

OPTIONS

ILLUSTRATED DRAWING 70.4137 Mid Weight Bar Kit, 4520

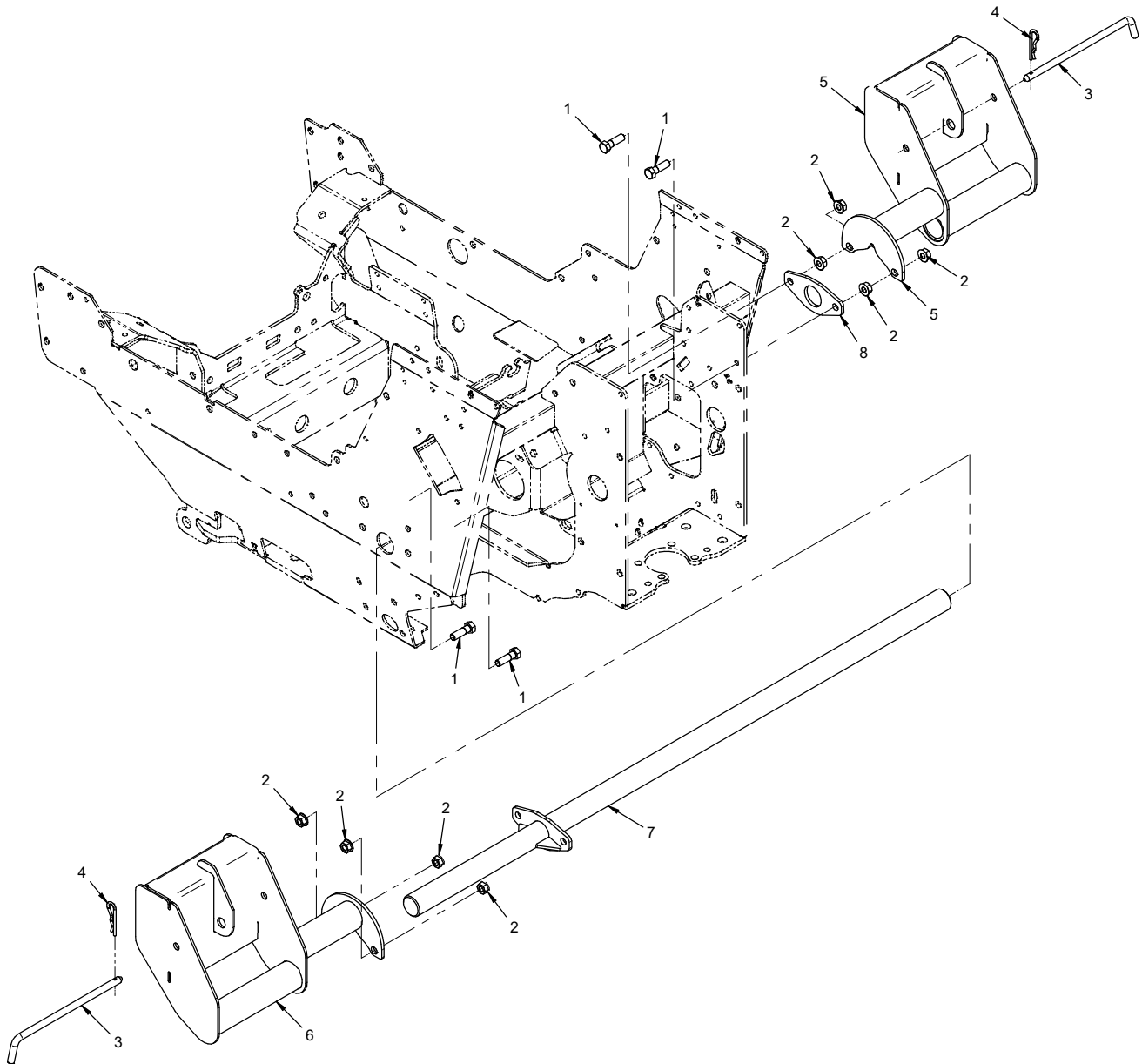

OPTIONS

70.4137 Mid Weight Bar Kit, 4520

REF.	PART NO.	DESCRIPTION	QTY.
1	90.0610	.Bolt, 3/8-16 USS x 1-1/4	4
2	99.SF06	.Nut, SRF 3/8-16 USS	8
3	64.0761	.Pin, Weight Secure 7.3" Usable	2
4	02.HP0416	.Hairpin, 1/8 X 2 ZP.	2
5	62.1449	.Frame, Weight Mid Right	1
6	62.1448	.Frame, Weight Mid Left	1
7	42.0455	.Shaft, Rear Anchor Mount	1
8	64.1029	.Plate, Rear Clamp Crossbar MT.	1